

REPUBLIQUE DU CAMEROUN

Paix-Travail-Patrie



REPUBLIC OF CAMEROON

Peace-Work-Fatherland

MINISTRY OF DEFENCE



HUMAN RESOURCE MANAGEMENT PROCEDURES MANUAL

VOLUME II

MILITARY PERSONNEL

*Produced with the technical support of the Ministry of the Public Service and
Administrative Reform*

2023 EDITION



H.E. Paul BIYA
President of the Republic of Cameroon



Mr DION NGUTE Joseph
Prime Minister, Head of Government



Mr BETI ASSOMO Joseph
Minister Delegate at the Presidency
in charge of Defence



Mr Joseph LE
Minister of the Public Service
And Administrative Reform

TABLE OF CONTENTS

PREFACE.....	6
GLOSSARY	7
LIST OF ACRONYMS AND ABBREVIATIONS	9
GENERAL LIST OF PROCEDURES.....	11
VOLUME I: POSITION OF MILITARY PERSONNEL.....	16
VOLUME II: PROMOTIONS OF MILITARY PERSONNEL.....	87
VOLUME III: DISCIPLINE OF MILITARY PERSONNEL.....	103
VOLUME IV: PENSIONS OF MILITARY PERSONNEL.....	144
VOLUME V: RECRUITMENT OF MILITARY PERSONNEL.....	243
VOLUME VI: PAYSLIP OF MILITARY PERSONNEL.....	253
STANDARD OPERATIONS IN THE PROCESSING CHAIN AND THE STAFFS.....	267
ANNEX.....	281

PREFACE

The Human Resource Management Procedures Manual of the Ministry of Defence was developed in line with the implementation of the National Governance Programme (NGP) approved on 29 June 2000 by the President of the Republic, His Excellency **Paul BIYA**.

It should be recalled that one of the main objectives of this Programme, revised in 2005, is to establish a “modern Public Administration” that is efficient; citizen-oriented and truly at the service of the user. It is harmoniously integrated into Cameroon’s 2035 economic and social development strategy, whose reference frameworks include the Growth and Employment Strategy Paper (GESP) and the National Development Strategy 2020 – 2030 (NDS30), among others.

By making this Human Resource Management Procedures Manual available to the public, the Ministry of Defence (MINDEF) intends to improve the service provided to users by popularising its human resource management principles which take into account the specificities of various professions involved in the accomplishment of its missions.

This managerial approach is intended to translate into action the provisions of Decree No. 2012/079 of 09 March 2012 to lay down rules and regulations governing the devolution of the management of State personnel and the payroll, as well as Prime Ministerial Instruction No. 003/CAB/PM of 24 January 2001, which calls upon Ministers to streamline the time frames and procedures for processing files within the public service.

In this light, we wish that this Manual enable our collaborators in charge of human resources and the entire staff of the Ministry of Defence to be clearly informed and educated on the procedures in force and to serve as a reference framework for the processing of staff files.

May this Human Resource Management Procedures Manual of the Ministry of Defence contribute to improving the governance of our Ministry and to tackling abuses./-

The Minister Delegate at the Presidency
in charge of Defence

BETI ASSOMO Joseph

GLOSSARY

Administrative instrument: a written document issued from or service rendered by a public authority or institution in the form of a law, ordinance, decree, decision, convention, treaty, agreement, instruction, circular, communiqué, attestation, certificate, note, report, authorisation, approval or record.

Certificate of intervention: document issued to a disaster victim to certify that the victim was affected and that the Fire Brigade has intervened. It is a document that is served to whom it may concern.

Constitution of file: set of documents to be submitted by the user and reference documents to be consulted by the Administration

Requirement: procedure to be completed by the applicant or by the person providing the requested service.

Deadline: maximum time for processing a file.

Dispatch runner: staff in charge of transmissions of files and liaison, liaison officer, Mail Bureau, etc.

User guide: a document that provides information to a natural or legal person applying for a service or benefit from a structure.

Initiator of the procedure: natural or legal person who initiates a procedure on their own behalf or on behalf of a third party.

Applicant/User: a legal or natural person and direct recipient of the instrument, service or end product; it may be internal (MINDEF staff) or external (staff from another ministry or any other person requesting a service).

Title of the requested service: name given to a service rendered or benefit offered by the public service to a user.

Service roll: staff information document.

Administrative Procedures Manual: an approved document that details the procedures of an organisation. It provides a comprehensive list of the products or services expected from an organisation, as well as the modalities and steps to access them.

Safety notice: notice summarising the measures taken to comply with the measures provided for by the safety regulations.

Cover page: a page containing the key parameters or information that identify an administrative procedure. These parameters include: the title of the procedure, the title of the document, the initiator of the procedure, the initiating entity, the reference documents, the requirements; the constitution of file, the deadlines, the signatory of the document and the delivery method.

Papier ministre: double-squared sheet used at the Ministry of Defence for handwritten applications.

Reference documents: set of documents available within the public service and essential for processing the user's file.

Required documents: set of documents required from the user of the service and essential for the processing of his/her file.

Service: provision of work vehicleried out to fulfil a legal or contractual obligation.

Administrative procedures: a set of standards, rules, instructions and guidelines formally provided for and to be followed in the performance of an activity.

Intervention report: internal document established at the end of an intervention which summarises the details of the intervention and automatically acts as a report.

Handling rule: constraint that applies to an action, an activity or a process.

Quality supervisor: official responsible for animating the quality policy in an organisation.

Signatory of the document: the authority who signs the requested document (the Minister, the Secretary of State, the Chief of Staff, etc.).

Reference text: legislative document (law) or regulatory document (decree, order, decision, etc.) that governs a benefit or service.

All levels: the superiors who signed the position papers.

Safety visit: a visit to an institution by a security commission for the purpose of assessing the security level of that institution.

LIST OF ACRONYMS AND ABBREVIATIONS

AC:	Central Services
BAN:	Naval Base
CBCR	Head of Mail and Follow-up Bureau
CBLR	Legislative and Regulatory Affairs Bureau
CBPS	Bureau Head of Pensions Service
CEMA:	Chief of Defence Staff
CEMAA:	Chief of Air Force Staff
CEMAT:	Chief of Army Staff
CEMM:	Chief of Navy Staff
CEMP/PR:	Chief of Staff of the Special Command Post at the Presidency of the Republic
CF	Financial Controller
CIMA:	Inter-African Conference on Insurance Markets
COMCNSP:	Commander of the National Fire Brigade
CSCA	Head of Mail and Records Service
CSE	Head of Engagement Service
CSER	Head of Studies and Regulatory Service
CSM	Head of Military Secretariat
DAAR	Department of Administrative and Regulatory Affairs
DCC:	Central Coordination Department
EMA:	Defence Staff
EMAA:	Air Force Staff
EMAT:	Army Staff
EMM:	Navy Staff
EPMS:	Military and Sports Physical Training
ESS:	Military Service Record
PNO:	Non-commissioned service member
GN:	National Gendarmerie
MINDEF:	Ministry of Defence
RG:	Gendarmerie Region
SED/CGN:	Secretariat of State for Defence in charge of the National Gendarmerie
SG	Secretary General

SOC:	Vehicleer NCO
UE	Elementary Unit

GENERAL LIST OF PROCEDURES

No.	TITLE OF THE PROCEDURE	PAGE
	VOLUME I: POSITIONS OF MILITARY PERSONNEL	
1.	ISSUING AN EXTENDED LEAVE PASS (30 and 60 days)	19
2.	PLACING A NON-COMMISSIONED SERVICE MEMBER ON INACTIVE STATUS	22
3.	PLACING AN OFFICER OUT OF SERVICE	25
4.	ISSUING A POST-NATAL LEAVE PASS	26
5.	EXTENDING A POST-NATAL LEAVE PASS	29
6.	ISSUING A SICK LEAVE PASS NOT EXCEEDING SIX MONTHS	30
7.	ISSUING A LEAVE OF ABSENCE FOR HEALTH REASONS FOR A MAXIMUM PERIOD OF THREE YEARS	31
8.	ISSUING AN EXTENDED SICK LEAVE PASS	33
9.	ISSUING AN EXTENDED SICK LEAVE PASS	35
10.	ISSUING RELEASE LEAVE TO AN OFFICER	37
11.	ISSUING AN AUTHORISATION FOR VEHICLEEER CHANGE TO AN OFFICER	38
12.	TERMINATION OF MILITARY STATUS FOR A NON-COMMISSIONED SERVICE MEMBER	40
13.	DISCHARGING A NON-COMMISSIONED SERVICE MEMBER	42
14.	ISSUING A LEAVE PASS ABROAD	43
15.	PUTTING AN OFFICER ON INACTIVE STATUS	46
16.	DISCHARGING AN OFFICER	50
17.	TERMINATION OF MILITARY STATUS OF AN OFFICER	52
18.	PLACING A GENERAL IN THE SECOND SECTION	54
19.	GRANTING RETIREMENT BENEFITS TO AN OFFICER	56
20.	PLACING A NON-COMMISSIONED SERVICE MEMBER ON RETIREMENT	60
	CHIEF OF DEFENCE STAFF	
21.	GRANTING A 30-DAY EXTENDED LEAVE PASS TO AN OFFICER	64
	COMPANY	
22.	GRANTING A 30-DAY EXTENDED LEAVE PASS TO A NON-COMMISSIONED SERVICE MEMBER	69
	SUPERIOR	
23.	ISSUING AN ATTESTATION OF EFFECTIVE PRESENCE TO AN OFFICER	72
24.	ISSUING A MISSION ORDER	74
25.	ISSUING A CASUAL LEAVE PASS	76
26.	ISSUING A SHORT-TERM CASUAL LEAVE PASS	78
27.	ISSUING A SPECIAL CASUAL LEAVE PASS	79
28.	ISSUING A MATERNITY LEAVE PASS	80

29.	ISSUING RELEASE LEAVE TO A NON-COMMISSIONED SERVICE MEMBER	81
30.	ISSUING AN AUTHORISATION FOR VEHICLE CHANGE TO A NON-COMMISSIONED SERVICE MEMBER	83
31.	ISSUING AN END-OF-COURSE CASUAL LEAVE PASS	85
VOLUME II: PROMOTION OF MILITARY PERSONNEL		
1.	PROMOTION TO THE RANK OF OFFICER	89
2.	ADMISSION TO THE OFFICERS' CORPS AND PROMOTION TO THE RANK OF SUB-LIEUTENANT OR MIDSHIPMAN OF A CHIEF WARRANT OFFICER OR CHIEF PETTY OFFICER	92
3.	ADVANCEMENT IN INCREMENTAL POSITION OF AN OFFICER	94
4.	PROMOTION OF A NON-COMMISSIONED SERVICE MEMBER TO A HIGHER RANK	99
5.	PROMOTION TO THE POSITION OF PRIVATE FIRST CLASS AND SEAMAN SECOND CLASS	101
VOLUME III: DISCIPLINE OF MILITARY PERSONNEL		
DEPARTMENT OF HUMAN RESOURCE		
OFFICERS		
1.	STRIKING AN OFFICER OFF THE ROLL OF ADVANCEMENT IN RANK/INCREMENTAL POSITION	107
2.	PLACING AN OFFICER ON INACTIVE STATUS BY WITHDRAWAL OF POST	112
3.	DISCHARGING AN OFFICER ON DISCIPLINARY GROUNDS	113
4.	COMPULSORY RETIREMENT OF AN OFFICER	114
5.	DISMISSAL OF AN OFFICER	115
6.	DEMOTION OF AN OFFICER	116
7.	AUTOMATIC DISCIPLINARY TRANSFER	117
NON-COMMISSIONED SERVICE MEMBER		
8.	REPRIMANDING A NON-COMMISSIONED SERVICE MEMBER	122
9.	WARNING A NON-COMMISSIONED SERVICE MEMBER	126
10.	DISCIPLINARY DUTY FOR A NON-COMMISSIONED SERVICE MEMBER	127
11.	REPRIMANDING A NON-COMMISSIONED SERVICE MEMBER	128
12.	REGULAR/MANDATORY DAYS OFF OF A NON-COMMISSIONED SERVICE MEMBER	129
13.	IMPRISONMENT OF A NON-COMMISSIONED SERVICE MEMBER	130
14.	AUTOMATIC DISCIPLINARY TRANSFER OF A NON-COMMISSIONED SERVICE MEMBER	131
15.	SUSPENSION OR WITHDRAWAL OF POST OF A NON-COMMISSIONED SERVICE MEMBER	132
16.	DEMOTION OF A RANK AND FILE FROM PRIVATE FIRST CLASS TO PRIVATE SECOND CLASS	133

17.	DEMOTION/CANCELLATION/TERMINATION OF ENLISTMENT OR RE-ENLISTMENT CONTRACT OF A NON-COMMISSIONED SERVICE MEMBER	134
18.	COMPULSORY RETIREMENT OF A NON-COMMISSIONED SERVICE MEMBER	135
	SECRETARIAT OF STATE FOR DEFENCE IN CHARGE OF THE NATIONAL GENDARMERIE	
19.	DEDUCTION OR SUSPENSION OF SALARY THROUGH DISCIPLINARY ACTION	137
	VOLUME IV: PENSIONS OF MILITARY PERSONNEL	
	NON-COMMISSIONED PERSONNEL PENSION	
1.	GRANTING A RETIREMENT PENSION	148
2.	GRANTING OF A RETIREMENT PENSION AND REVALORISATION OF A LIFE-LONG INVALIDITY PENSION	152
3.	GRANTING OF A RETIREMENT PENSION, REVALORISATION OF A LIFE-LONG INVALIDITY PENSION AND GRANTING OF AN INSTALLATION ALLOWANCE	154
4.	GRANTING OF A RETIREMENT PENSION, REVALORISATION OF A LIFE-LONG INVALIDITY PENSION AND ALLOCATION OF BENEFITS FROM THE MOBILISABLE RESERVE	156
5.	GRANTING A RETIREMENT PENSION AND A LIFE-LONG INVALIDITY PENSION	158
6.	GRANTING A RETIREMENT PENSION AND A TEMPORARY INVALIDITY PENSION	160
7.	GRANTING OF A RETIREMENT PENSION, REVALORISATION OF A LIFE-LONG INVALIDITY PENSION, ALLOCATION OF BENEFITS FROM THE MOBILISABLE RESERVE AND GRANTING OF AN INSTALLATION ALLOWANCE	162
8.	ALLOCATING BENEFITS FROM THE MOBILISABLE RESERVE	164
9.	GRANTING AND REVERSION OF A RETIREMENT PENSION, REVALORISATION AND REVERSION OF A LIFE-LONG INVALIDITY PENSION, ALLOCATION AND REVERSION OF BENEFITS FROM THE MOBILISABLE RESERVE	166
10.	GRANTING A LIFE-LONG INVALIDITY PENSION	168
11.	GRANTING A TEMPORARY INVALIDITY PENSION	170
12.	GRANTING DEATH BENEFITS AND A REVERSIONARY PENSION	172
13.	GRANTING DEATH BENEFITS, A REVERSIONARY PENSION AND REVERSION OF A LIFE-LONG INVALIDITY PENSION	174
14.	GRANTING ORPHAN'S TEMPORARY PENSION	176
15.	GRANTING DEATH BENEFITS AND ORPHAN'S TEMPORARY PENSION	178
16.	GRANTING DEATH BENEFITS, ORPHAN'S TEMPORARY PENSION AND REVERSION OF A LIFE-LONG INVALIDITY PENSION	180
17.	GRANTING A REVERSIONARY PENSION	182
18.	GRANTING AND REVERSION OF A LIFE-LONG INVALIDITY PENSION	184
19.	GRANTING DEATH BENEFITS AND SURVIVOR'S PENSION	186
20.	REIMBURSEMENT OF PENSION DEDUCTIONS	188

<i>NON-COMMISSIONED PERSONNEL PENSION</i>		
21.	AUTHORISING PAYMENT OF WAGES AND REIMBURSEMENT OF PENSION DEDUCTIONS	<i>191</i>
22.	GRANTING DEATH BENEFITS	<i>194</i>
23.	GRANTING A RETIREMENT PENSION	<i>196</i>
24.	GRANTING OF A RETIREMENT PENSION AND REVALORISATION OF A LIFE-LONG INVALIDITY PENSION	<i>200</i>
25.	GRANTING OF A RETIREMENT PENSION, REVALORISATION OF A LIFE-LONG INVALIDITY PENSION AND GRANTING OF AN INSTALLATION ALLOWANCE	<i>202</i>
26.	GRANTING OF A RETIREMENT PENSION, REVALORISATION OF A LIFE-LONG INVALIDITY PENSION AND ALLOCATION OF BENEFITS FROM THE MOBILISABLE RESERVE	<i>203</i>
27.	GRANTING A RETIREMENT PENSION AND A LIFE-LONG INVALIDITY PENSION	<i>205</i>
28.	GRANTING A RETIREMENT PENSION AND A TEMPORARY INVALIDITY PENSION	<i>207</i>
29.	GRANTING OF A RETIREMENT PENSION, REVALORISATION OF A LIFE-LONG INVALIDITY PENSION, ALLOCATION OF BENEFITS FROM THE MOBILISABLE RESERVE AND GRANTING OF AN INSTALLATION ALLOWANCE	<i>209</i>
30.	ALLOCATING BENEFITS FROM THE MOBILISABLE RESERVE	<i>211</i>
31.	GRANTING AND REVERSION OF A RETIREMENT PENSION, REVALORISATION AND REVERSION OF A LIFE-LONG INVALIDITY PENSION, ALLOCATION AND REVERSION OF BENEFITS FROM THE MOBILISABLE RESERVE	<i>213</i>
32.	GRANTING A LIFE-LONG INVALIDITY PENSION	<i>216</i>
33.	GRANTING A TEMPORARY INVALIDITY PENSION	<i>218</i>
34.	GRANTING DEATH BENEFITS AND A REVERSIONARY PENSION	<i>220</i>
35.	GRANTING DEATH BENEFITS, A REVERSIONARY PENSION AND REVERSION OF A LIFE-LONG INVALIDITY PENSION	<i>222</i>
36.	GRANTING ORPHAN'S TEMPORARY PENSION	<i>224</i>
37.	GRANTING DEATH BENEFITS AND ORPHAN'S TEMPORARY PENSION	<i>226</i>
38.	GRANTING DEATH BENEFITS, ORPHAN'S TEMPORARY PENSION AND REVERSION OF A LIFE-LONG INVALIDITY PENSION	<i>228</i>
39.	GRANTING A REVERSIONARY PENSION	<i>230</i>
40.	GRANTING AND REVERSION OF A LIFE-LONG INVALIDITY PENSION	<i>232</i>
41.	GRANTING DEATH BENEFITS AND SURVIVOR'S PENSION	<i>234</i>
42.	REIMBURSEMENT OF PENSION DEDUCTIONS	<i>236</i>
43.	AUTHORISING PAYMENT OF WAGES AND REIMBURSEMENT OF PENSION DEDUCTIONS	<i>238</i>
44.	GRANTING DEATH BENEFITS	<i>240</i>
VOLUME V: RECRUITMENT OF MILITARY PERSONNEL		
1.	LAUNCHING RECRUITMENT INTO THE DEFENCE FORCES	<i>245</i>
2.	SPECIAL ENLISTMENT OF AN OFFICER	<i>247</i>
3.	TEMPORARY ENLISTMENT OF A NON-COMMISSIONED SERVICE MEMBER	<i>251</i>

VOLUME VI: ALLOWANCES OF MILITARY PERSONNEL		
<i>OFFICER'S PENSION</i>		
1.	GRANTING TECHNICAL ALLOWANCE	256
2.	GRANTING VEHICLE MAINTENANCE ALLOWANCE	259
<i>NON-COMMISSIONED SERVICE PERSONNEL PENSION</i>		
3.	GRANTING TECHNICAL ALLOWANCE	261
4.	GRANTING VEHICLE MAINTENANCE ALLOWANCE	264
5.	PAYMENT OF NON-ACCOMMODATION ALLOWANCE	265
TOTAL: 107 PROCEDURES		

VOLUME I

POSITIONS OF MILITARY PERSONNEL

LIST OF PROCEDURES

<i>No.</i>	<i>TITLE OF THE PROCEDURE</i>
PROCEDURES ON POSITIONS OF OFFICERS AND NON-COMMISSIONED SERVICE PERSONNEL	
1.	ISSUING AN EXTENDED LEAVE PASS (30 and 60 days)
2.	PLACING A NON-COMMISSIONED SERVICE MEMBER ON INACTIVE STATUS
3.	PLACING AN OFFICER OUT OF SERVICE
4.	ISSUING A POST-NATAL LEAVE PASS
5.	EXTENDING A POST-NATAL LEAVE PASS
6.	ISSUING A SICK LEAVE PASS NOT EXCEEDING SIX MONTHS
7.	ISSUING A LEAVE OF ABSENCE FOR HEALTH REASONS FOR A MAXIMUM PERIOD OF THREE YEARS
8.	ISSUING AN EXTENDED SICK LEAVE PASS
9.	ISSUING AN EXTENDED SICK LEAVE PASS
10.	OBTENTION D'UN CONGE DE LIBERATION D'UN OFFICIER
11.	ISSUING AN AUTHORISATION FOR VEHICLEEER CHANGE TO AN OFFICER
12.	TERMINATION OF MILITARY STATUS FOR A NON-COMMISSIONED SERVICE MEMBER
13.	DISCHARGING A NON-COMMISSIONED SERVICE MEMBER
14.	ISSUING A LEAVE PASS ABROAD
15.	PUTTING AN OFFICER ON INACTIVE STATUS
16.	DISCHARGING AN OFFICER
17.	TERMINATION OF MILITARY STATUS OF AN OFFICER
18.	PLACING A GENERAL IN THE SECOND SECTION
19.	GRANTING RETIREMENT BENEFITS TO AN OFFICER
20.	PLACING A NON-COMMISSIONED SERVICE MEMBER ON RETIREMENT
CHIEF OF DEFENCE STAFF	
21.	GRANTING A 30-DAY EXTENDED LEAVE PASS TO AN OFFICER
COMPANY	
22.	GRANTING A 30-DAY EXTENDED LEAVE PASS TO A NON-COMMISSIONED SERVICE MEMBER
SUPERIOR	
23.	ISSUING AN ATTESTATION OF EFFECTIVE PRESENCE TO AN OFFICER
24.	ISSUING A MISSION ORDER
25.	ISSUING A CASUAL LEAVE PASS
26.	ISSUING A SHORT-TERM CASUAL LEAVE PASS
27.	ISSUING A SPECIAL CASUAL LEAVE PASS
28.	ISSUING A MATERNITY LEAVE PASS
29.	ISSUING RELEASE LEAVE TO A NON-COMMISSIONED SERVICE MEMBER
30.	ISSUING AN AUTHORISATION FOR VEHICLEEER CHANGE TO A NON-COMMISSIONED SERVICE MEMBER
31.	ISSUING AN END-OF-COURSE CASUAL LEAVE PASS

HUMAN RESOURCE

PROCEDURE No. 01/MINDEF/DRH/PPM/I
ISSUING AN EXTENDED LEAVE PASS (30 and 60 days)

TITLE OF THE INSTRUMENT: Extended leave pass

INITIATOR OF THE PROCEDURE: Applicant

INITIATING ENTITY: Personnel Movements Service

PLACE OF SUBMISSION OF FILE: Assignment unit

REFERENCE INSTRUMENTS:

- Law No. 67/LF/9 of 12 June 1967 on the general organisation of Defence;
- Law No. 80/12 of 14 July 1980 on general rules and regulations governing servicemen;
- Decree No. 80/257 of 15 July 1980 to lay down general rules and regulations governing the remuneration schemes applicable to military personnel of the Armed Forces, amended by Decree No. 84/926 of 30 July 1984;
- Decree No. 2001/178 of 25 July 2001 on the general organisation of Defence and Central Staff;
- Decree No. 2001/188 of 25 July 2001 to lay down special rules and regulations governing the corps of Active Officers of the Defence Forces;
- Decree No. 2001/219 of 06 August 2001 to lay down special rules and regulations governing non-commissioned officers of the Defence Forces;
- Decree No. 2011/408 of 09 December 2011 to organise the Government;
- Decree No. 2011/412 of 09 December 2011 to reorganise the Presidency of the Republic;
- Decree No. 2012/386 of 14 September 2012 to amend Decree No. 2001/177 of 25 July 2001 to organise the Ministry of Defence;
- Decree No. 2007/199 of 07 July 2007 to lay down Rules of General Discipline in the Defence Forces.

REQUIREMENTS:

- should have completed at least six (06) months of service;
- **be approved by the superior.**

CONSTITUTION OF FILE:

** Required documents:*

- stamped application addressed to the Minister
- all supporting documents.

** Reference document:* Staff file







DEADLINE: Seven (07) days

SIGNATORY OF THE INSTRUMENT: the Minister Delegate

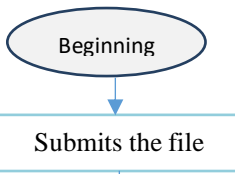
DELIVERY METHOD: Notification

QUALITY SUPERVISOR: the Director of Human Resource

PROCESSING

DEPARTMENT OF HUMAN RESOURCE		PROCEDURE No. 01/MINDEF/DRH/PPM/I ISSUING AN EXTENDED LEAVE PASS (30 and 60 days)	Deadline	Procedure start date: 2023
				Procedure version: 1.0
				Page
Intervening parties		Stages		Handling rules
	Applicant			R1: Ensure that the file is complete
	Assignment unit Head	<ul style="list-style-type: none"> - Receives the physical file through the chain of command - Registers the file - Checks compliance of the physical file - Forwards the file to the Department of Human Resource through the chain of command 		R2: Check the consistency and conformity of documents in the file
	Director of Human Resource	<ul style="list-style-type: none"> - Receives the physical file - Reviews the file - Assigns the file 		R3: Ensure that the candidate is eligible
	Head of Personnel Movements Service	<ul style="list-style-type: none"> - Receives the physical file - Reviews the file - Assigns the file 		
	Head of Civilian Personnel Management Bureau	<ul style="list-style-type: none"> - Receives the physical file through the chain of command - Registers the file - Checks compliance of the physical file - Initiates the draft instrument - Forwards the file 		
	Head of Personnel Movements Service	<ul style="list-style-type: none"> - Receives the physical file - Checks data conformity - Initials the draft instrument - Forwards the file 		

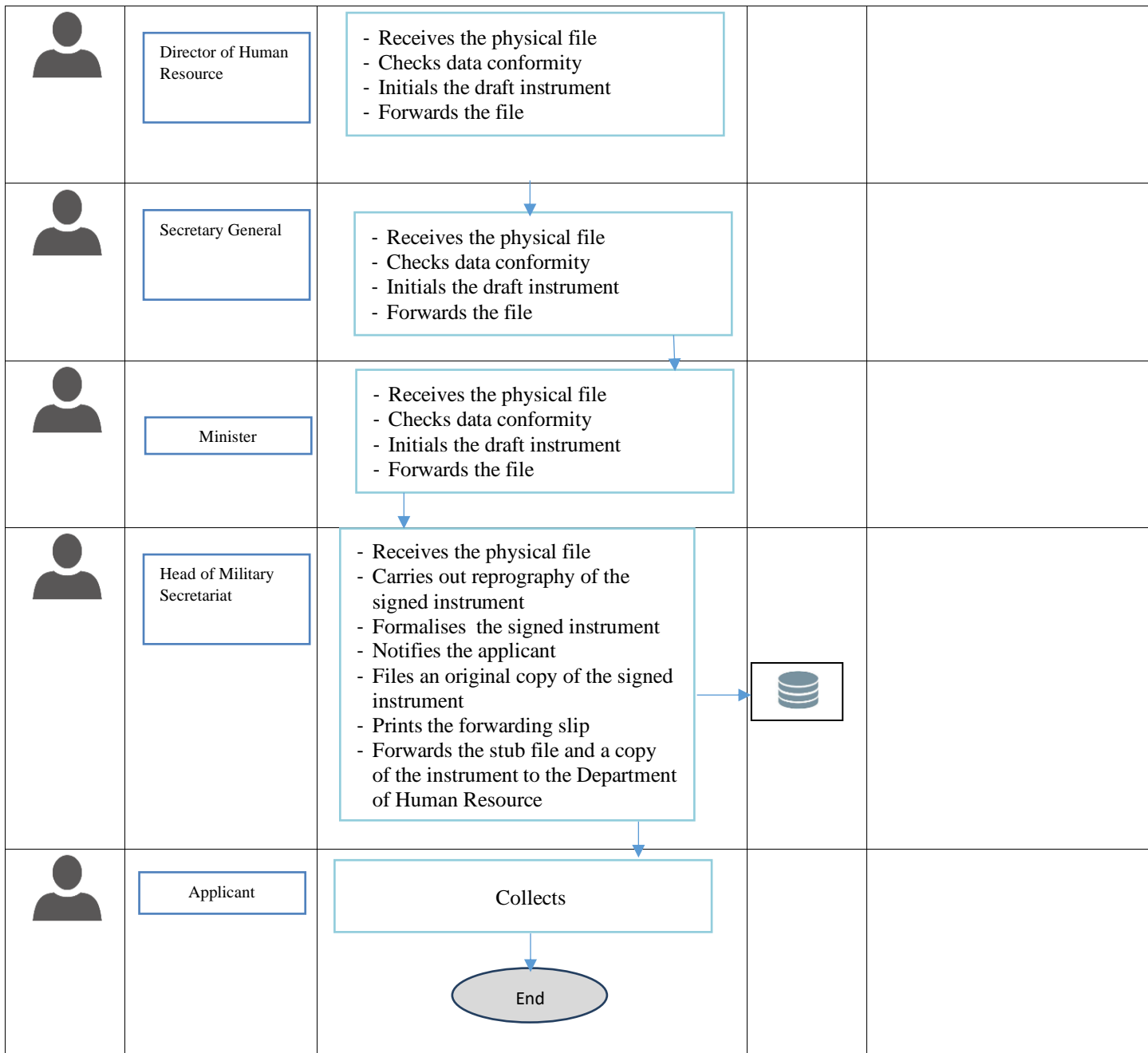

PROCEDURE No. 02/MINDEF/DRH/PPM/I
**PLACING A NON-COMMISSIONED SERVICE MEMBER ON
INACTIVE STATUS**

TITLE OF THE INSTRUMENT: Decision to place a non-commissioned service member on inactive status

INITIATOR OF THE PROCEDURE: Administration

INITIATING ENTITY: Personnel Movements Service

REFERENCE INSTRUMENTS:

- Law No. 67/LF/9 of 12 June 1967 on the general organisation of Defence;
- Law No. 80/12 of 14 July 1980 on general rules and regulations governing servicemen;
- Decree No. 80/257 of 15 July 1980 to lay down general rules and regulations governing the remuneration schemes applicable to military personnel of the Armed Forces, amended by Decree No. 84/926 of 30 July 1984;
- Decree No. 2001/178 of 25 July 2001 on the general organisation of Defence and Central Staff;
- Decree No. 2001/219 of 06 August 2001 to lay down special rules and regulations governing non-commissioned officers of the Defence Forces;
- Decree No. 2011/408 of 09 December 2011 to organise the Government;
- Decree No. 2011/412 of 09 December 2011 to reorganise the Presidency of the Republic;
- Decree No. 2012/386 of 14 September 2012 to amend Decree No. 2001/177 of 25 July 2001 to organise the Ministry of Defence;
- Decree No. 2007/199 of 07 July 2007 to lay down Rules of General Discipline in the Defence Forces.

PLACE OF SUBMISSION OF FILE: Assignment unit

REQUIREMENTS: Be on medical or post-natal leave or be laid off or withdrawn from employment.

CONSTITUTION OF FILE:

*** Required documents:**

*** Reference document:** Document granting medical or post-natal leave







DEADLINE: Thirty (30) days

SIGNATORY OF THE INSTRUMENT: the Minister

DELIVERY METHOD: Collection

QUALITY SUPERVISOR: the Director of Human Resource

PROCESSING

DEPARTMENT OF HUMAN RESOURCE		PROCEDURE No. 02/MINDEF/DRH/PPM/I <u>PLACING A NON-COMMISSIONED SERVICE MEMBER ON INACTIVE STATUS</u>	Deadline	Procedure start date: 2023
				Procedure version: 1.0
				Page
<i>Intervening parties</i>		<i>Stages</i>	<i>Handling rules</i>	
	<div style="border: 1px solid black; padding: 5px; width: fit-content;">Director of Human Resource</div>	<div style="border: 1px solid black; padding: 10px; margin-bottom: 5px;"> <ul style="list-style-type: none"> - Receives the physical file - Reviews the file - Assigns the file </div>		<p>R1: Ensure that the file is complete</p> <p>R2: Check the consistency and conformity of documents in the file</p>
	<div style="border: 1px solid black; padding: 5px; width: fit-content;">Head of Personnel Movements Service</div>	<div style="border: 1px solid black; padding: 10px; margin-bottom: 5px;"> <ul style="list-style-type: none"> - Receives the physical file - Reviews the file - Assigns the file </div>		<p>R3: Ensure that the candidate is eligible</p>
	<div style="border: 1px solid black; padding: 5px; width: fit-content;">Head of Military Personnel Management Bureau</div>	<div style="border: 1px solid black; padding: 10px; margin-bottom: 5px;"> <ul style="list-style-type: none"> - Receives the physical file through the chain of command - Registers the file - Checks compliance of the physical file - Initiates the draft instrument - Forwards the file </div>		
	<div style="border: 1px solid black; padding: 5px; width: fit-content;">Head of Personnel Movements Service</div>	<div style="border: 1px solid black; padding: 10px; margin-bottom: 5px;"> <ul style="list-style-type: none"> - Receives the physical file - Checks data conformity - Initials the draft instrument - Forwards the file </div>		
	<div style="border: 1px solid black; padding: 5px; width: fit-content;">Director of Human Resource</div>	<div style="border: 1px solid black; padding: 10px; margin-bottom: 5px;"> <ul style="list-style-type: none"> - Receives the physical file - Checks data conformity - Initials the draft instrument - Forwards the file </div>		
	<div style="border: 1px solid black; padding: 5px; width: fit-content;">Secretary General</div>	<div style="border: 1px solid black; padding: 10px; margin-bottom: 5px;"> <ul style="list-style-type: none"> - Receives the physical file - Checks data conformity - Initials the draft instrument - Forwards the file </div>		

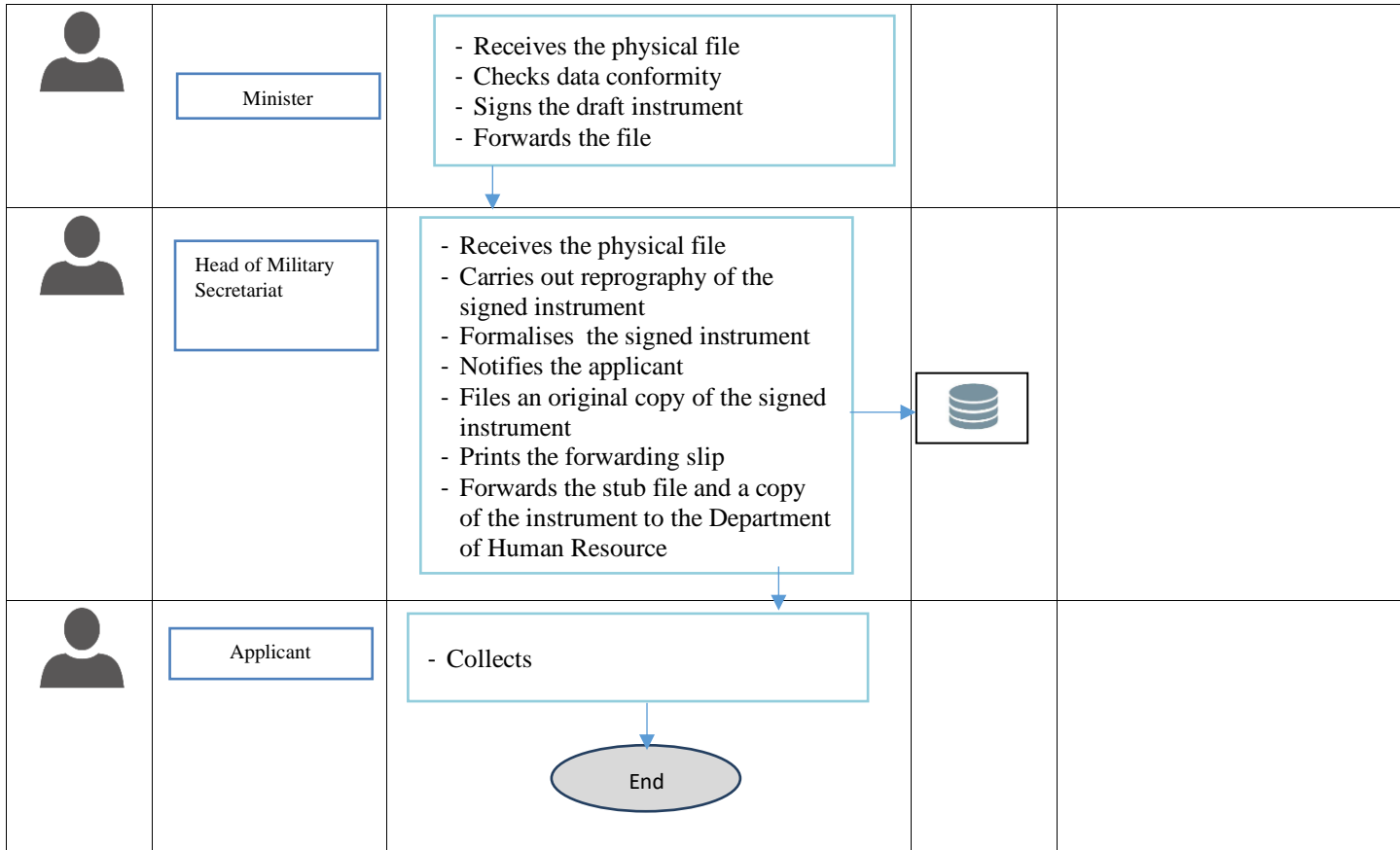

PROCEDURE No. 03/MINDEF/DRH/PPM/I
PLACING AN OFFICER OUT OF SERVICE

TITLE OF THE INSTRUMENT: Joint order placing an officer out of service

INITIATOR OF THE PROCEDURE: Administration

INITIATING ENTITY: Personnel Movements Service

REFERENCE INSTRUMENTS:

- Law No. 67/LF/9 of 12 June 1967 on the general organisation of Defence;
- Law No. 80/12 of 14 July 1980 on general rules and regulations governing servicemen;
- Decree No. 80/257 of 15 July 1980 to lay down general rules and regulations governing the remuneration schemes applicable to military personnel of the Armed Forces, amended by Decree No. 84/926 of 30 July 1984;
- Decree No. 2001/178 of 25 July 2001 on the general organisation of Defence and Central Staff;
- Decree No. 2001/188 of 25 July 2001 to lay down special rules and regulations governing the corps of Active Officers of the Defence Forces;
- Decree No. 2001/219 of 06 August 2001 to lay down special rules and regulations governing non-commissioned officers of the Defence Forces;
- Decree No. 2011/408 of 09 December 2011 to organise the Government;
- Decree No. 2011/412 of 09 December 2011 to reorganise the Presidency of the Republic;
- Decree No. 2012/386 of 14 September 2012 to amend Decree No. 2001/177 of 25 July 2001 to organise the Ministry of Defence;
- Decree No. 2007/199 of 07 July 2007 to lay down Rules of General Discipline in the Defence Forces.

PLACE OF SUBMISSION OF FILE: Assignment unit

REQUIREMENT: Be a vehicleeer service member.

CONSTITUTION OF FILE:

* *Required documents:*

* *Reference document:* Application from the applicant service

DEADLINE: Thirty (30) days

SIGNATORY OF THE INSTRUMENT: the Ministers concerned

DELIVERY METHOD: Notification

QUALITY SUPERVISOR: the Director of Human Resource

**PROCESSING: cf. processing chain: PROCEDURE No. 02/MINDEF/DRH/PPM/I
PLACING A NON-COMMISSIONED SERVICE MEMBER ON INACTIVE STATUS**

PROCEDURE No. 04/MINDEF/DRH/PPM/I
ISSUING A POST-NATAL LEAVE PASS

TITLE OF THE INSTRUMENT: Decision granting a post-natal leave pass

INITIATOR OF THE PROCEDURE: Applicant

INITIATING ENTITY: Personnel Movements Service

REFERENCE INSTRUMENTS:

- Law No. 67/LF/9 of 12 June 1967 on the general organisation of Defence;
- Law No. 80/12 of 14 July 1980 on general rules and regulations governing servicemen;
- Decree No. 80/257 of 15 July 1980 to lay down general rules and regulations governing the remuneration schemes applicable to military personnel of the Armed Forces, amended by Decree No. 84/926 of 30 July 1984;
- Decree No. 2001/178 of 25 July 2001 on the general organisation of Defence and Central Staff;
- Decree No. 2001/188 of 25 July 2001 to lay down special rules and regulations governing the corps of Active Officers of the Defence Forces;
- Decree No. 2001/219 of 06 August 2001 to lay down special rules and regulations governing non-commissioned officers of the Defence Forces;
- Decree No. 2011/408 of 09 December 2011 to organise the Government;
- Decree No. 2011/412 of 09 December 2011 to reorganise the Presidency of the Republic;
- Decree No. 2012/386 of 14 September 2012 to amend Decree No. 2001/177 of 25 July 2001 to organise the Ministry of Defence;
- Decree No. 2007/199 of 07 July 2007 to lay down Rules of General Discipline in the Defence Forces.

PLACE OF SUBMISSION OF FILE: Assignment unit

REQUIREMENTS:

- be a female service member;
- should have given birth.

CONSTITUTION OF FILE:

*** Required documents:**

- stamped application addressed to the Minister;
- certificate of delivery of the 6th month indicating the date of delivery.

*** Reference document:** Staff file







DEADLINE: Fourteen (14) days

SIGNATORY OF THE INSTRUMENT: the Minister

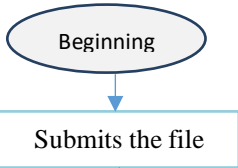
DELIVERY METHOD: Notification

QUALITY SUPERVISOR: the Director of Human Resource

PROCESSING

DEPARTMENT OF HUMAN RESOURCE		PROCEDURE No. 04/MINDEF/DRH/PPM/I <u>ISSUING A POST-NATAL LEAVE</u> <u>PASS</u>	Deadline	Procedure start date: 2023
				Procedure version: 1.0
				Page
Intervening parties		Stages		Handling rules
	Applicant			R1: Ensure that the file is complete R2: Check the consistency and conformity of documents in the file
	Assignment unit Head	<ul style="list-style-type: none"> - Receives the physical file through the chain of command - Registers the file - Checks compliance of the physical file - Forwards the file to the Department of Human Resource through the chain of command 		R3: Ensure that the candidate is eligible
	Director of Human Resource	<ul style="list-style-type: none"> - Receives the physical file - Reviews the file - Assigns the file 		
	Head of Personnel Movements Service	<ul style="list-style-type: none"> - Receives the physical file - Reviews the file - Assigns the file 		
	Head of Military Personnel Management Bureau	<ul style="list-style-type: none"> - Receives the physical file through the chain of command - Registers the file - Checks compliance of the physical file - Initiates the draft instrument - Forwards the file 		
	Head of Personnel Movements Service	<ul style="list-style-type: none"> - Receives the physical file - Checks data conformity - Initials the draft instrument - Forwards the file 		

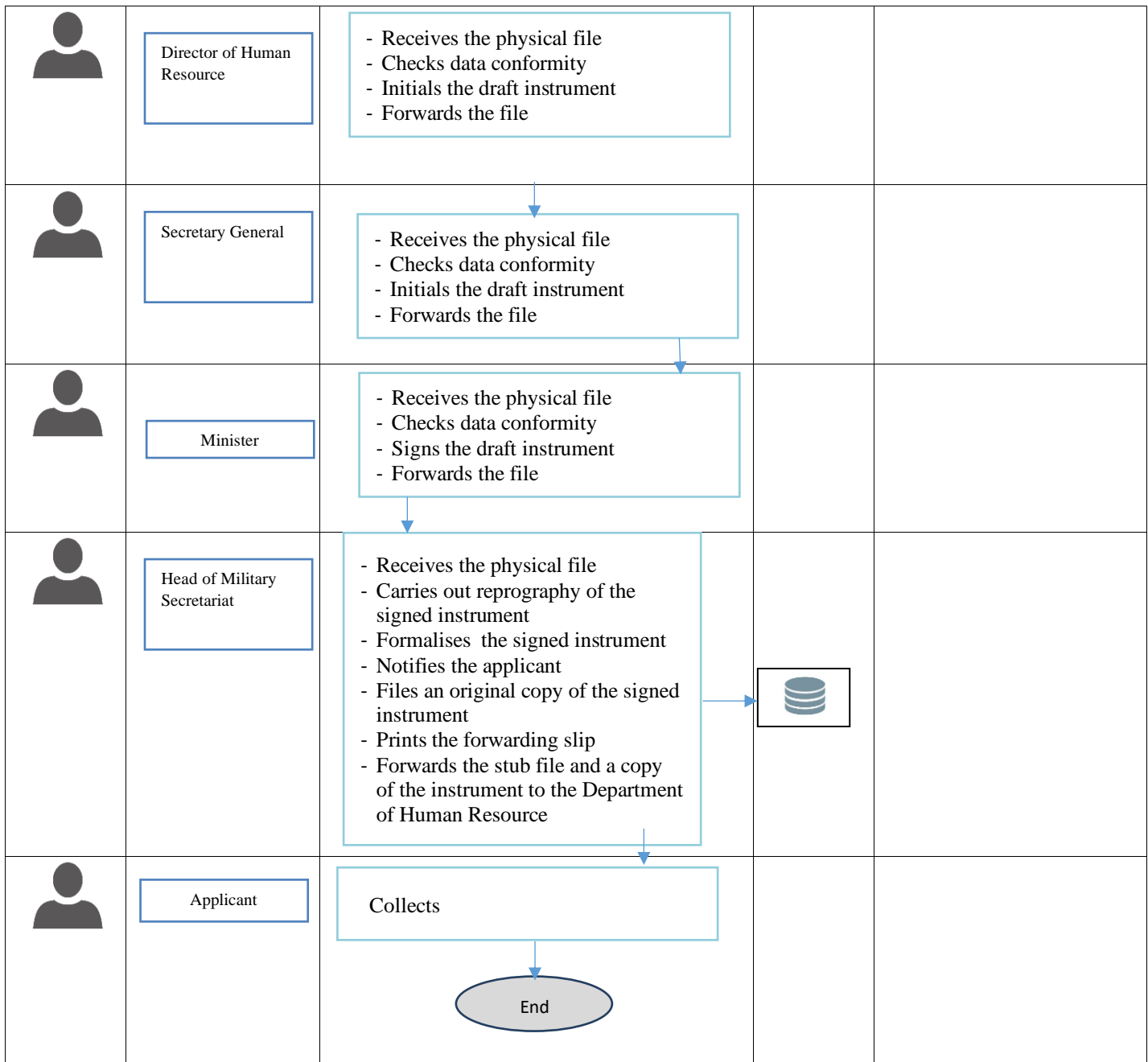

PROCEDURE No. 05/MINDEF/DRH/PPM/I
EXTENDING A POST-NATAL LEAVE PASS

TITLE OF THE INSTRUMENT: Decision extending a post-natal leave pass

INITIATOR OF THE PROCEDURE: Applicant

INITIATING ENTITY: Personnel Movements Service

REFERENCE INSTRUMENTS:

- Law No. 67/LF/9 of 12 June 1967 on the general organisation of Defence;
- Law No. 80/12 of 14 July 1980 on general rules and regulations governing servicemen;
- Decree No. 80/257 of 15 July 1980 to lay down general rules and regulations governing the remuneration schemes applicable to military personnel of the Armed Forces, amended by Decree No. 84/926 of 30 July 1984;
- Decree No. 2001/178 of 25 July 2001 on the general organisation of Defence and Central Staff;
- Decree No. 2001/188 of 25 July 2001 to lay down special rules and regulations governing the corps of Active Officers of the Defence Forces;
- Decree No. 2001/219 of 06 August 2001 to lay down special rules and regulations governing non-commissioned officers of the Defence Forces;
- Decree No. 2011/408 of 09 December 2011 to organise the Government;
- Decree No. 2011/412 of 09 December 2011 to reorganise the Presidency of the Republic;
- Decree No. 2012/386 of 14 September 2012 to amend Decree No. 2001/177 of 25 July 2001 to organise the Ministry of Defence;
- Decree No. 2007/199 of 07 July 2007 to lay down Rules of General Discipline in the Defence Forces.

PLACE OF SUBMISSION OF FILE: Assignment unit

REQUIREMENTS:

- be a female service member;
- should have conceived during the post-natal leave.

CONSTITUTION OF FILE:

*** Required documents:**

- unstamped application addressed to the Minister;
- certificate of delivery of the 6th month indicating the date of delivery.

*** Reference document:** Staff file

DEADLINE: Fourteen (14) days

SIGNATORY OF THE INSTRUMENT: the Minister

DELIVERY METHOD: Notification

QUALITY SUPERVISOR: the Director of Human Resource

**PROCESSING: cf. processing chain: PROCEDURE No. 04/MINDEF/DRH/PPM/I
ISSUING A POST-NATAL LEAVE PASS**

PROCEDURE No. 06/MINDEF/DRH/PPM/I
ISSUING A SICK LEAVE PASS NOT EXCEEDING SIX MONTHS

TITLE OF THE INSTRUMENT: Decision granting a sick leave not exceeding six months

INITIATOR OF THE PROCEDURE: Applicant

INITIATING ENTITY: Personnel Movements Service

REFERENCE INSTRUMENTS:

- Law No. 67/LF/9 of 12 June 1967 on the general organisation of Defence;
- Law No. 80/12 of 14 July 1980 on general rules and regulations governing servicemen;
- Decree No. 80/257 of 15 July 1980 to lay down general rules and regulations governing the remuneration schemes applicable to military personnel of the Armed Forces, amended by Decree No. 84/926 of 30 July 1984;
- Decree No. 2001/178 of 25 July 2001 on the general organisation of Defence and Central Staff;
- Decree No. 2001/188 of 25 July 2001 to lay down special rules and regulations governing the corps of Active Officers of the Defence Forces;
- Decree No. 2001/219 of 06 August 2001 to lay down special rules and regulations governing non-commissioned officers of the Defence Forces;
- Decree No. 2011/408 of 09 December 2011 to organise the Government;
- Decree No. 2011/412 of 09 December 2011 to reorganise the Presidency of the Republic;
- Decree No. 2012/386 of 14 September 2012 to amend Decree No. 2001/177 of 25 July 2001 to organise the Ministry of Defence;
- Decree No. 2007/199 of 07 July 2007 to lay down Rules of General Discipline in the Defence Forces.

PLACE OF SUBMISSION OF FILE: Assignment unit

REQUIREMENTS:

- be a service member who has been wounded or suffering from an illness or infirmity duly certified by a military doctor;
- be unable to perform his/her duties.

CONSTITUTION OF FILE:

** Required documents:*

- unstamped application addressed to the Minister;
- medical record;
- medical certificate issued by the military doctor.

** Reference documents:*

DEADLINE: Fourteen (14) days

SIGNATORY OF THE INSTRUMENT: the Minister

DELIVERY METHOD: Collection

QUALITY SUPERVISOR: the Director of Human Resource

**PROCESSING: cf. processing chain: PROCEDURE NO.04/MINDEF/DRH/PPM/I
ISSUING A POST-NATAL LEAVE PASS**

PROCEDURE No. 07/MINDEF/DRH/PPM/I
**ISSUING A LEAVE OF ABSENCE FOR HEALTH REASONS
FOR A MAXIMUM PERIOD OF THREE YEARS**

TITLE OF THE INSTRUMENT: Decision granting a leave of absence for health reasons for a maximum period of three years (granted in 3-6 month renewable periods)

INITIATOR OF THE PROCEDURE: Applicant

INITIATING ENTITY: Personnel Movements Service

REFERENCE INSTRUMENTS:

- Law No. 67/LF/9 of 12 June 1967 on the general organisation of Defence;
- Law No. 80/12 of 14 July 1980 on general rules and regulations governing servicemen;
- Decree No. 80/257 of 15 July 1980 to lay down general rules and regulations governing the remuneration schemes applicable to military personnel of the Armed Forces, amended by Decree No. 84/926 of 30 July 1984;
- Decree No. 2001/178 of 25 July 2001 on the general organisation of Defence and Central Staff;
- Decree No. 2001/188 of 25 July 2001 to lay down special rules and regulations governing the corps of Active Officers of the Defence Forces;
- Decree No. 2001/219 of 06 August 2001 to lay down special rules and regulations governing non-commissioned officers of the Defence Forces;
- Decree No. 2011/408 of 09 December 2011 to organise the Government;
- Decree No. 2011/412 of 09 December 2011 to reorganise the Presidency of the Republic;
- Decree No. 2012/386 of 14 September 2012 to amend Decree No. 2001/177 of 25 July 2001 to organise the Ministry of Defence;
- Decree No. 2007/199 of 07 July 2007 to lay down Rules of General Discipline in the Defence Forces.

PLACE OF SUBMISSION OF FILE: Assignment unit

REQUIREMENTS:

- be a service member who has been wounded or suffering from an illness or infirmity duly certified by a military doctor;
- be unable to perform his/her duties.

CONSTITUTION OF FILE:

*** Required documents:**

- unstamped application addressed to the Minister;
- medical record;
- medical certificate issued by the military doctor.

*** Reference documents:**

- staff file;
- arms record (SPA).

DEADLINE: Fourteen (14) days

SIGNATORY OF THE INSTRUMENT: the Minister

DELIVERY METHOD: Notification

QUALITY SUPERVISOR: the Director of Human Resource

PROCESSING: cf. processing chain: *PROCEDURE No. 04/MINDEF/DRH/PPM/I*
ISSUING A POST-NATAL LEAVE PASS

**PROCEDURE No. 08/MINDEF/DRH/PPM/I
ISSUING AN EXTENDED SICK LEAVE PASS**

TITLE OF THE INSTRUMENT: Decision granting an extended sick leave for a maximum period of three years

INITIATOR OF THE PROCEDURE: Applicant

INITIATING ENTITY: Personnel Movements Service

REFERENCE INSTRUMENTS:

- Law No. 67/LF/9 of 12 June 1967 on the general organisation of Defence;
- Law No. 80/12 of 14 July 1980 on general rules and regulations governing servicemen;
- Decree No. 80/257 of 15 July 1980 to lay down general rules and regulations governing the remuneration schemes applicable to military personnel of the Armed Forces, amended by Decree No. 84/926 of 30 July 1984;
- Decree No. 2001/178 of 25 July 2001 on the general organisation of Defence and Central Staff;
- Decree No. 2001/188 of 25 July 2001 to lay down special rules and regulations governing the corps of Active Officers of the Defence Forces;
- Decree No. 2001/219 of 06 August 2001 to lay down special rules and regulations governing non-commissioned officers of the Defence Forces;
- Decree No. 2011/408 of 09 December 2011 to organise the Government;
- Decree No. 2011/412 of 09 December 2011 to reorganise the Presidency of the Republic;
- Decree No. 2012/386 of 14 September 2012 to amend Decree No. 2001/177 of 25 July 2001 to organise the Ministry of Defence;
- Decree No. 2007/199 of 07 July 2007 to lay down Rules of General Discipline in the Defence Forces.

PLACE OF SUBMISSION OF FILE: Assignment unit

REQUIREMENTS:

- be a service member who has been wounded or suffering from an illness or infirmity duly certified by a military doctor;
- be unable to perform his/her duties.

CONSTITUTION OF FILE:

*** Required documents:**

- unstamped application addressed to the Minister;
- medical record;
- medical certificate issued by the military doctor.

*** Reference documents:**

- staff file;
- arms record (SPA).

DEADLINE: Fourteen (14) days

SIGNATORY OF THE INSTRUMENT: the Minister

DELIVERY METHOD: Collection

QUALITY SUPERVISOR: the Director of Human Resource

**PROCESSING: cf. processing chain: PROCEDURE No. 04/MINDEF/DRH/PPM/I
ISSUING A POST-NATAL LEAVE PASS**

**PROCEDURE No. 09/MINDEF/DRH/PPM/I
ISSUING AN EXTENDED SICK LEAVE PASS**

TITLE OF THE INSTRUMENT: Decision granting an extended sick leave pass

INITIATOR OF THE PROCEDURE: Applicant

INITIATING ENTITY: Personnel Movements Service

REFERENCE INSTRUMENTS:

- Law No. 67/LF/9 of 12 June 1967 on the general organisation of Defence;
- Law No. 80/12 of 14 July 1980 on general rules and regulations governing servicemen;
- Decree No. 80/257 of 15 July 1980 to lay down general rules and regulations governing the remuneration schemes applicable to military personnel of the Armed Forces, amended by Decree No. 84/926 of 30 July 1984;
- Decree No. 2001/178 of 25 July 2001 on the general organisation of Defence and Central Staff;
- Decree No. 2001/188 of 25 July 2001 to lay down special rules and regulations governing the corps of Active Officers of the Defence Forces;
- Decree No. 2001/219 of 06 August 2001 to lay down special rules and regulations governing non-commissioned officers of the Defence Forces;
- Decree No. 2011/408 of 09 December 2011 to organise the Government;
- Decree No. 2011/412 of 09 December 2011 to reorganise the Presidency of the Republic;
- Decree No. 2012/386 of 14 September 2012 to amend Decree No. 2001/177 of 25 July 2001 to organise the Ministry of Defence;
- Decree No. 2007/199 of 07 July 2007 to lay down Rules of General Discipline in the Defence Forces.

PLACE OF SUBMISSION OF FILE: Assignment unit

REQUIREMENTS:

- be a service member who has been wounded or suffering from an illness or infirmity duly certified by a military doctor;
- be unable to perform his/her duties.

CONSTITUTION OF FILE:

*** Required documents:**

- unstamped application addressed to the Minister;
- medical record;
- medical certificate issued by the military doctor.

*** Reference documents:**

- staff file;
- arms record (SPA).

DEADLINE: Fourteen (14) days

SIGNATORY OF THE INSTRUMENT: the Minister

DELIVERY METHOD: Notification

QUALITY SUPERVISOR: the Director of Human Resource

**PROCESSING: cf. processing chain: PROCEDURE No. 04/MINDEF/DRH/PPM/I
ISSUING A POST-NATAL LEAVE PASS**

**PROCEDURE No. 10/MINDEF/DRH/PPM/I
GRANTING A RELEASE LEAVE PASS TO AN OFFICER**

TITLE OF THE INSTRUMENT: Release leave pass

INITIATOR OF THE PROCEDURE: Applicant/Administration

INITIATING ENTITY: Personnel Movements Service

REFERENCE INSTRUMENTS:

- Law No. 67/LF/9 of 12 June 1967 on the general organisation of Defence;
- Law No. 80/12 of 14 July 1980 on general rules and regulations governing servicemen;
- Decree No. 80/257 of 15 July 1980 to lay down general rules and regulations governing the remuneration schemes applicable to military personnel of the Armed Forces, amended by Decree No. 84/926 of 30 July 1984;
- Decree No. 2001/178 of 25 July 2001 on the general organisation of Defence and Central Staff;
- Decree No. 2001/188 of 25 July 2001 to lay down special rules and regulations governing the corps of Active Officers of the Defence Forces;
- Decree No. 2001/219 of 06 August 2001 to lay down special rules and regulations governing non-commissioned officers of the Defence Forces;
- Decree No. 2011/408 of 09 December 2011 to organise the Government;
- Decree No. 2011/412 of 09 December 2011 to reorganise the Presidency of the Republic;
- Decree No. 2012/386 of 14 September 2012 to amend Decree No. 2001/177 of 25 July 2001 to organise the Ministry of Defence;
- Decree No. 2007/199 of 07 July 2007 to lay down Rules of General Discipline in the Defence Forces.

PLACE OF SUBMISSION OF FILE: Assignment unit

REQUIREMENTS:

- be a service member serving under a contract/conversion;
- should have served for at least two months before going on retirement;
- should be retired.

CONSTITUTION OF FILE:

*** Required documents:**

- unstamped application addressed to the Minister;
- retirement decision.

*** Reference documents:**

- Staff file;
- arms record (SPA).

DEADLINE: Thirty (30) days

SIGNATORY OF THE INSTRUMENT: the Minister

DELIVERY METHOD: Collection

QUALITY SUPERVISOR: the Director of Human Resource

**PROCESSING: cf. processing chain: PROCEDURE No. 04/MINDEF/DRH/PPM/I
ISSUING A POST-NATAL LEAVE PASS**

**PROCEDURE No. 11/MINDEF/DRH/PPM/I
ISSUING AN AUTHORISATION FOR VEHICLEER
CHANGE TO AN OFFICER**

TITLE OF THE INSTRUMENT: Authorisation for vehicleer change by an officer

INITIATOR OF THE PROCEDURE: Applicant

INITIATING ENTITY: Personnel Movements Service

REFERENCE INSTRUMENTS:

- Law No. 67/LF/9 of 12 June 1967 on the general organisation of Defence;
- Law No. 80/12 of 14 July 1980 on general rules and regulations governing servicemen;
- Decree No. 80/257 of 15 July 1980 to lay down general rules and regulations governing the remuneration schemes applicable to military personnel of the Armed Forces, amended by Decree No. 84/926 of 30 July 1984;
- Decree No. 2001/178 of 25 July 2001 on the general organisation of Defence and Central Staff;
- Decree No. 2001/188 of 25 July 2001 to lay down special rules and regulations governing the corps of Active Officers of the Defence Forces;
- Decree No. 2001/219 of 06 August 2001 to lay down special rules and regulations governing non-commissioned officers of the Defence Forces;
- Decree No. 2011/408 of 09 December 2011 to organise the Government;
- Decree No. 2011/412 of 09 December 2011 to reorganise the Presidency of the Republic;
- Decree No. 2012/386 of 14 September 2012 to amend Decree No. 2001/177 of 25 July 2001 to organise the Ministry of Defence;
- Decree No. 2007/199 of 07 July 2007 to lay down Rules of General Discipline in the Defence Forces.

PLACE OF SUBMISSION OF FILE: Assignment unit

REQUIREMENTS:

- be a vehicleer service member;
- should have served for at least two months before going on retirement;
- should be retired.

CONSTITUTION OF FILE:

*** Required documents:**

- unstamped application addressed to the Minister;
- retirement decision.

*** Reference documents:**

DEADLINE: Thirty (30) days

SIGNATORY OF THE INSTRUMENT: the Minister

DELIVERY METHOD: Collection

QUALITY SUPERVISOR: the Director of Human Resource

**PROCESSING: cf. processing chain: PROCEDURE No. 04/MINDEF/DRH/PPM/I
ISSUING A POST-NATAL LEAVE PASS**

PROCEDURE No. 12/MINDEF/DRH/PPM/I
TERMINATION OF MILITARY STATUS FOR A NON-COMMISSIONED SERVICE MEMBER

TITLE OF THE INSTRUMENT: Order terminating the military status of a non-commissioned service member

INITIATOR OF THE PROCEDURE: Administration/Applicant

INITIATING ENTITY: Personnel Movements Service

PLACE OF SUBMISSION OF FILE: Assignment unit

REFERENCE INSTRUMENTS:

- Law No. 67/LF/9 of 12 June 1967 on the general organisation of Defence;
- Law No. 80/12 of 14 July 1980 on general rules and regulations governing servicemen;
- Decree No. 80/257 of 15 July 1980 to lay down general rules and regulations governing the remuneration schemes applicable to military personnel of the Armed Forces, amended by Decree No. 84/926 of 30 July 1984;
- Decree No. 2001/178 of 25 July 2001 on the general organisation of Defence and Central Staff;
- Decree No. 2001/219 of 06 August 2001 to lay down special rules and regulations governing non-commissioned officers of the Defence Forces;
- Decree No. 2011/408 of 09 December 2011 to organise the Government;
- Decree No. 2011/412 of 09 December 2011 to reorganise the Presidency of the Republic;
- Decree No. 2012/386 of 14 September 2012 to amend Decree No. 2001/177 of 25 July 2001 to organise the Ministry of Defence;
- Decree No. 2007/199 of 07 July 2007 to lay down Rules of General Discipline in the Defence Forces.

REQUIREMENTS:

- should have resigned;
- should have lost his/her rank (loss of Cameroonian nationality, conviction for a criminal offence, unsuspended prison sentence, dismissal by judgment, revocation).

CONSTITUTION OF FILE:

** Required documents:*

- letter of resignation;
- committal order;
- demotion order.

** Reference documents:*

DEADLINE: Thirty (30) days

SIGNATORY OF THE INSTRUMENT: the Minister

DELIVERY METHOD: Collection

QUALITY SUPERVISOR: the Director of Human Resource

PROCESSING: cf. processing chain: *PROCEDURE No. 04/MINDEF/DRH/PPM/I*
ISSUING A POST-NATAL LEAVE PASS

PROCEDURE No. 13/MINDEF/DRH/PPM/I
**DISCHARGING A NON-COMMISSIONED SERVICE
MEMBER**

TITLE OF THE INSTRUMENT: Order discharging a non-commissioned service member

INITIATOR OF THE PROCEDURE: Applicant

INITIATING ENTITY: Personnel Movements Service

REFERENCE INSTRUMENTS:

- Law No. 67/LF/9 of 12 June 1967 on the general organisation of Defence;
- Law No. 80/12 of 14 July 1980 on general rules and regulations governing servicemen;
- Decree No. 80/257 of 15 July 1980 to lay down general rules and regulations governing the remuneration schemes applicable to military personnel of the Armed Forces, amended by Decree No. 84/926 of 30 July 1984;
- Decree No. 2001/178 of 25 July 2001 on the general organisation of Defence and Central Staff;
- Decree No. 2001/219 of 06 August 2001 to lay down special rules and regulations governing non-commissioned officers of the Defence Forces;
- Decree No. 2011/408 of 09 December 2011 to organise the Government;
- Decree No. 2011/412 of 09 December 2011 to reorganise the Presidency of the Republic;
- Decree No. 2012/386 of 14 September 2012 to amend Decree No. 2001/177 of 25 July 2001 to organise the Ministry of Defence;
- Decree No. 2007/199 of 07 July 2007 to lay down Rules of General Discipline in the Defence Forces.

PLACE OF SUBMISSION OF FILE: Assignment unit

REQUIREMENTS:

- be suffering from an illness or infirmity incompatible with continued service or be subject to a disciplinary measure following an offence against honour or probity or following the extension beyond three years of non-activity by withdrawal from employment.

CONSTITUTION OF FILE:

*** Required documents:**

- unstamped application addressed to the Minister;
- medical certificate/medical record;
- all supporting documents.

DEADLINE: Thirty (30) days

SIGNATORY OF THE INSTRUMENT: the Minister

DELIVERY METHOD: Collection

QUALITY SUPERVISOR: the Director of Human Resource

PROCESSING: cf. processing chain: PROCEDURE No. 04/MINDEF/DRH/PPM/I
ISSUING A POST-NATAL LEAVE PASS

**PROCEDURE No. 14/MINDEF/DRH/PPM/I
GRANTING PERMISSION FOR LEAVE ABROAD**

TITLE OF THE INSTRUMENT: Permission for leave abroad

INITIATOR OF THE PROCEDURE: Applicant

INITIATING ENTITY: Personnel Movements Service

REFERENCE INSTRUMENTS:

- Law No. 67/LF/9 of 12 June 1967 on the general organisation of Defence;
- Law No. 80/12 of 14 July 1980 on general rules and regulations governing servicemen;
- Decree No. 80/257 of 15 July 1980 to lay down general rules and regulations governing the remuneration schemes applicable to military personnel of the Armed Forces, amended by Decree No. 84/926 of 30 July 1984;
- Decree No. 2001/178 of 25 July 2001 on the general organisation of Defence and Central Staff;
- Decree No. 2001/188 of 25 July 2001 to lay down special rules and regulations governing the corps of Active Officers of the Defence Forces;
- Decree No. 2001/219 of 06 August 2001 to lay down special rules and regulations governing non-commissioned officers of the Defence Forces;
- Decree No. 2011/408 of 09 December 2011 to organise the Government;
- Decree No. 2011/412 of 09 December 2011 to reorganise the Presidency of the Republic;
- Decree No. 2012/386 of 14 September 2012 to amend Decree No. 2001/177 of 25 July 2001 to organise the Ministry of Defence;
- Decree No. 2007/199 of 07 July 2007 to lay down Rules of General Discipline in the Defence Forces.

PLACE OF SUBMISSION OF FILE: Assignment unit

REQUIREMENTS:

- have more than one year of service;
- have a leave of absence for the current year.

CONSTITUTION OF FILE:

*** Required documents:**

- unstamped application addressed to the Minister, specifying the period and address of the place where the leave will be spent;
- annual leave pass.

*** Reference documents:**







DEADLINE: Thirty (30) days

SIGNATORY OF THE INSTRUMENT: the Minister

DELIVERY METHOD: Notification

QUALITY SUPERVISOR: the Director of Human Resource

PROCESSING

DEPARTMENT OF HUMAN RESOURCE		PROCEDURE No. 14/MINDEF/DRH/PPM/I <u>GRANTING PERMISSION FOR LEAVE ABROAD</u>	Deadline	Procedure start date: 2023
				Procedure version: 1.0
				Page
<i>Intervening parties</i>		<i>Stages</i>		
<i>Handling rules</i>				
 <div data-bbox="288 633 499 685" style="border: 1px solid black; padding: 2px; width: fit-content; margin-left: auto; margin-right: auto;">Applicant</div>		<div data-bbox="671 544 874 611" style="border: 1px solid black; border-radius: 50%; padding: 5px; display: inline-block;">Beginning</div> ↓ <div data-bbox="667 645 911 707" style="border: 1px solid black; padding: 5px; display: inline-block;">Submits the file</div> ↓		<p>R1: Ensure that the file is complete</p> <p>R2: Check the consistency and conformity of documents in the file</p>
 <div data-bbox="288 824 499 902" style="border: 1px solid black; padding: 2px; width: fit-content; margin-left: auto; margin-right: auto;">Assignment Unit Head</div>		<ul style="list-style-type: none"> - Receives the physical file through the chain of command - Registers the file - Checks compliance of the physical file - Forwards the file to the Department of Military Security through the chain of command 		<p>R3: Ensure that the candidate is eligible</p>
 <div data-bbox="288 1048 499 1126" style="border: 1px solid black; padding: 2px; width: fit-content; margin-left: auto; margin-right: auto;">Department of Military Security</div>		<ul style="list-style-type: none"> - Receives the physical file through the chain of command - Checks compliance of the physical file - Conducts investigations - Conducts due diligence with the Ministry of External Relations - Forwards the file to the Department of Human Resource 		
 <div data-bbox="288 1346 499 1451" style="border: 1px solid black; padding: 2px; width: fit-content; margin-left: auto; margin-right: auto;">Director of Human Resource</div>		<ul style="list-style-type: none"> - Receives the physical file - Reviews the file - Assigns the file 		
 <div data-bbox="288 1534 499 1675" style="border: 1px solid black; padding: 2px; width: fit-content; margin-left: auto; margin-right: auto;">Head of Personnel Movements Service</div>		<ul style="list-style-type: none"> - Receives the physical file - Reviews the file - Assigns the file 		
 <div data-bbox="288 1753 499 1910" style="border: 1px solid black; padding: 2px; width: fit-content; margin-left: auto; margin-right: auto;">Head of Military Personnel Management Bureau</div>		<ul style="list-style-type: none"> - Receives the physical file through the chain of command - Registers the file - Checks compliance of the physical file - Initiates the draft instrument - Forwards the file 		

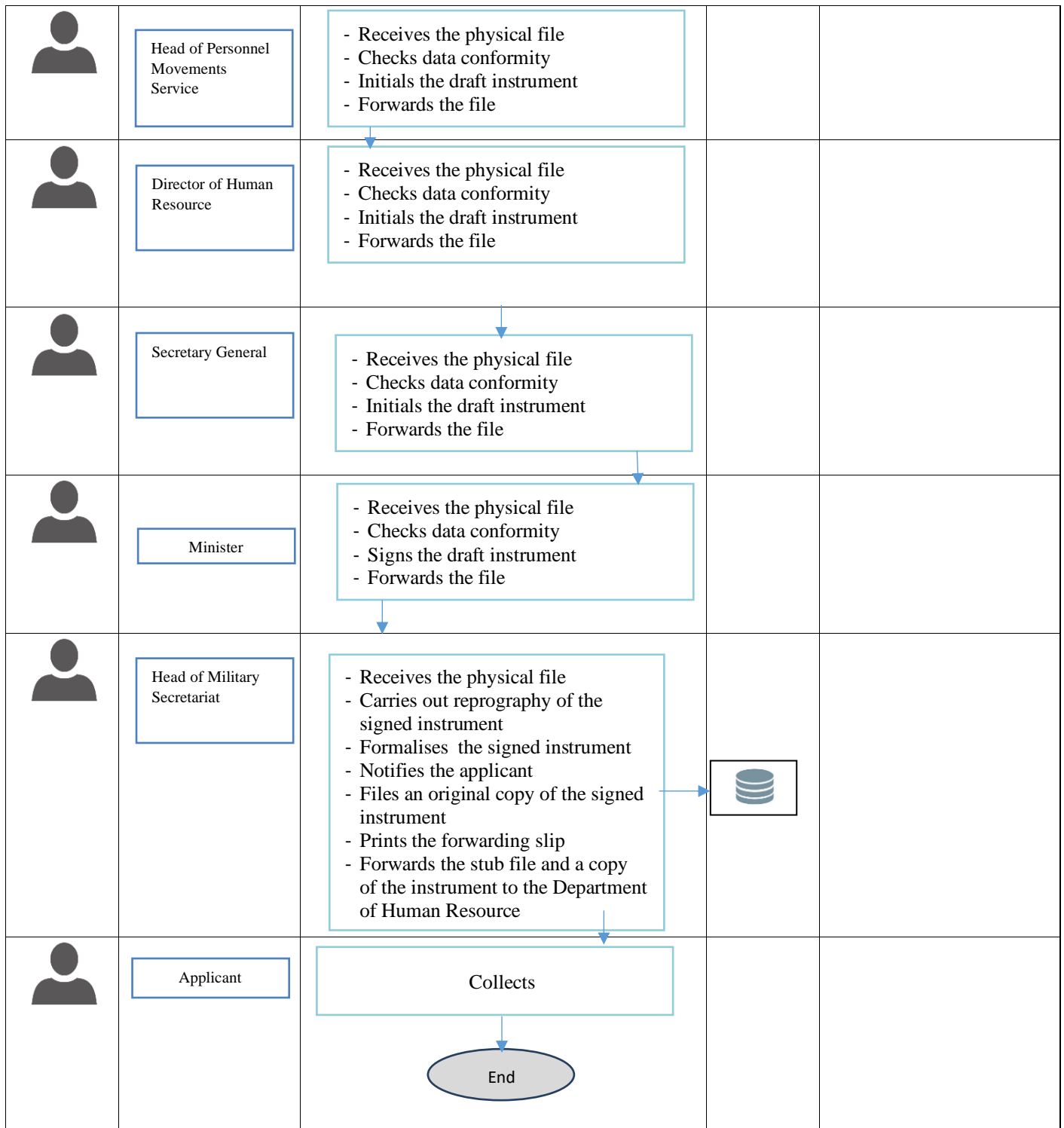

**PROCEDURE No. 15/MINDEF/DRH/PPM/I
PUTTING AN OFFICER ON INACTIVE STATUS**

TITLE OF THE INSTRUMENT: Decree to put an officer on inactive status

INITIATOR OF THE PROCEDURE: Administration

INITIATING ENTITY: Personnel Movements Service

PLACE OF SUBMISSION OF FILE: Assignment unit

REFERENCE INSTRUMENTS:

- Law No. 67/LF/9 of 12 June 1967 on the general organisation of Defence;
- Law No. 80/12 of 14 July 1980 on general rules and regulations governing servicemen;
- Decree No. 80/257 of 15 July 1980 to lay down general rules and regulations governing the remuneration schemes applicable to military personnel of the Armed Forces, amended by Decree No. 84/926 of 30 July 1984;
- Decree No. 2001/178 of 25 July 2001 on the general organisation of Defence and Central Staff;
- Decree No. 2001/188 of 25 July 2001 to lay down special rules and regulations governing the corps of Active Officers of the Defence Forces;
- Decree No. 2011/408 of 09 December 2011 to organise the Government;
- Decree No. 2011/412 of 09 December 2011 to reorganise the Presidency of the Republic;
- Decree No. 2012/386 of 14 September 2012 to amend Decree No. 2001/177 of 25 July 2001 to organise the Ministry of Defence;
- Decree No. 2007/199 of 07 July 2007 to lay down Rules of General Discipline in the Defence Forces.

REQUIREMENTS: Be on a leave of absence for medical or post-natal reasons, on assignment or on withdrawal from employment.

CONSTITUTION OF FILE:

*** Required documents:**

*** Reference document:** Document confirming the leave for medical reasons or post-natal leave or the lay-off or withdrawal of post .







DEADLINE: Thirty (30) days

SIGNATORY OF THE INSTRUMENT: the President of the Republic

DELIVERY METHOD: Notification

QUALITY SUPERVISOR: the Director of Human Resource

PROCESSING

DEPARTMENT OF HUMAN RESOURCE	PROCEDURE No. 15/MINDEF/PR/PPM/ I <u>PUTTING AN OFFICER ON INACTIVE STATUS</u>	Deadline	Procedure start date: 2023 Procedure version: 1.0 Page
<i>Intervening parties</i>	<i>Stages</i>		<i>Handling rules</i>
 Staff/Secretariat of State for Defence  Director of Human Resource  Head of Personnel Movements Service  Head of Military Personnel Management Bureau  Head of Personnel Movements Service  Head of Personnel Movements Service	<p style="text-align: center;">Beginning</p> <div style="border: 1px solid black; padding: 5px; margin-bottom: 10px;"> - Initiates the file - Forwards the file to the Department of Human Resource </div> <div style="border: 1px solid black; padding: 5px; margin-bottom: 10px;"> - Receives the physical file - Reviews - Assigns the file </div> <div style="border: 1px solid black; padding: 5px; margin-bottom: 10px;"> - Receives the physical file - Checks data conformity - Assigns the file </div> <div style="border: 1px solid black; padding: 5px; margin-bottom: 10px;"> - Receives the physical file through the chain of command - Registers the file - Checks compliance of the physical file - Initiates the draft instrument - Initiates the memorandum - Forwards the file </div> <div style="border: 1px solid black; padding: 5px; margin-bottom: 10px;"> - Receives the physical file - Checks data conformity - Initials the draft instrument and the memorandum </div> <div style="border: 1px solid black; padding: 5px;"> - Receives the physical file - Checks data conformity - Initials the draft instrument - Forwards the file </div>		<p>R1: Ensure that the file is complete</p> <p>R2: Check the consistency and conformity of documents in the file</p> <p>R3: Ensure that the candidate is eligible</p>

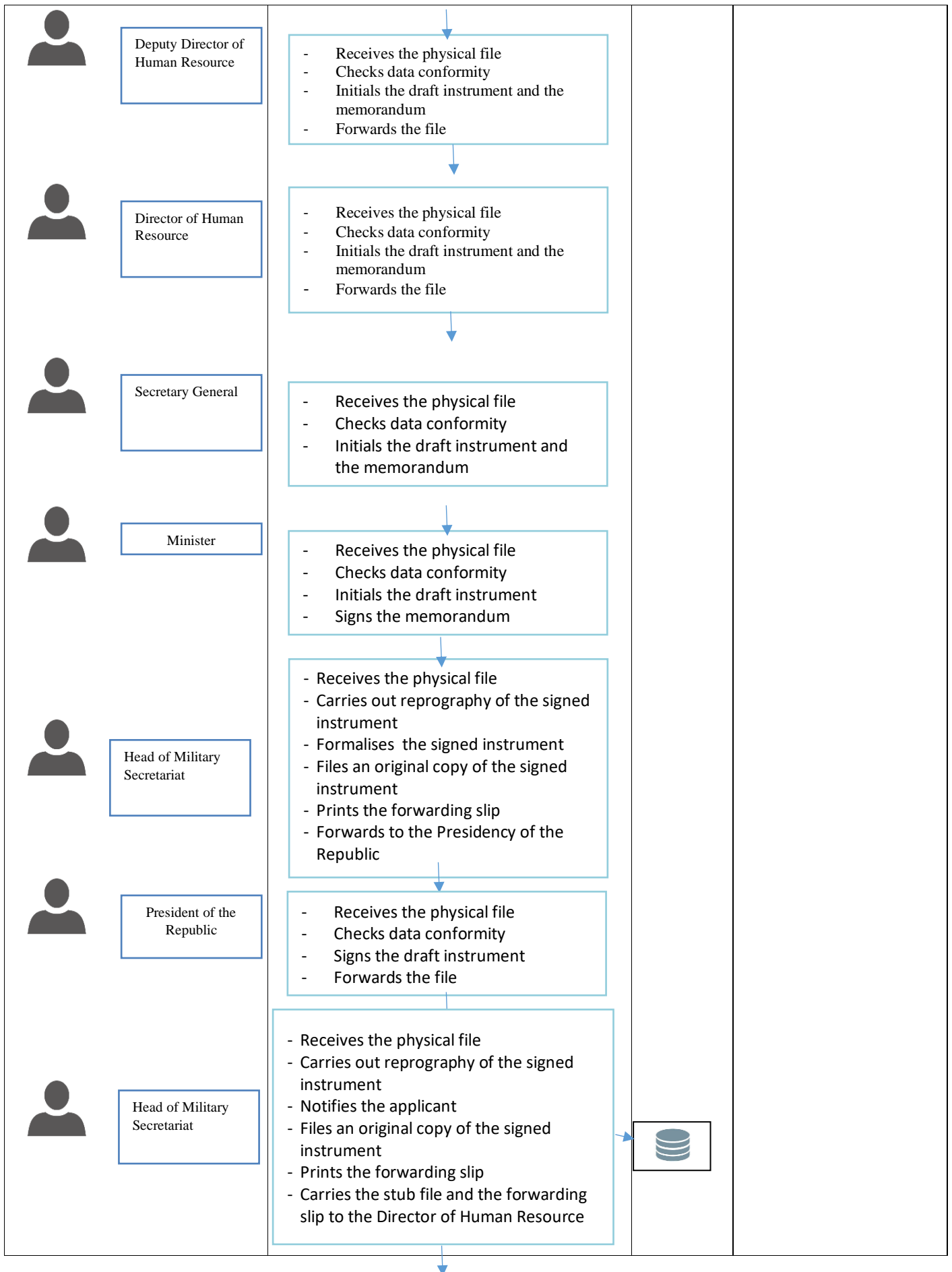

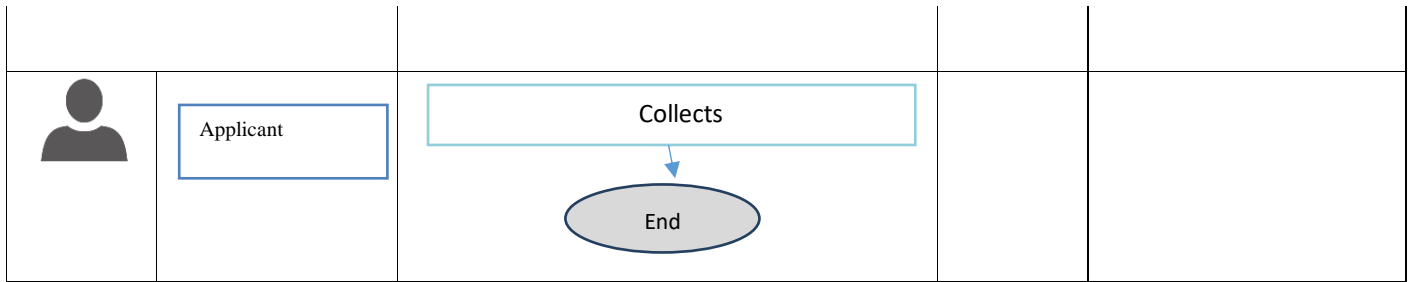

PROCEDURE No. 16/MINDEF/DRH/PPM/I
DISCHARGING AN OFFICER

TITLE OF THE INSTRUMENT: Decree to discharge an officer

INITIATOR OF THE PROCEDURE: Applicant

INITIATING ENTITY: Chief of Staff

PLACE OF SUBMISSION OF FILE: Assignment unit

REFERENCE INSTRUMENTS:

- Law No. 67/LF/9 of 12 June 1967 on the general organisation of Defence;
- Law No. 80/12 of 14 July 1980 on general rules and regulations governing servicemen;
- Decree No. 80/257 of 15 July 1980 to lay down general rules and regulations governing the remuneration schemes applicable to military personnel of the Armed Forces, amended by Decree No. 84/926 of 30 July 1984;
- Decree No. 2001/178 of 25 July 2001 on the general organisation of Defence and Central Staff;
- Decree No. 2001/188 of 25 July 2001 to lay down special rules and regulations governing the corps of Active Officers of the Defence Forces;
- Decree No. 2011/408 of 09 December 2011 to organise the Government;
- Decree No. 2011/412 of 09 December 2011 to reorganise the Presidency of the Republic;
- Decree No. 2012/386 of 14 September 2012 to amend Decree No. 2001/177 of 25 July 2001 to organise the Ministry of Defence;
- Decree No. 2007/199 of 07 July 2007 to lay down Rules of General Discipline in the Defence Forces.

REQUIREMENTS:

- be suffering from an illness or infirmity incompatible with continued service or be subject to a disciplinary measure following an offence against honour or probity or following the extension beyond three years of non-activity by withdrawal from employment.

CONSTITUTION OF FILE:

*** Required documents:**

- unstamped application addressed to the Minister;
- medical certificate/medical record;
- all supporting documents.

*** Reference documents:**

DEADLINE: Thirty (30) days

SIGNATORY OF THE INSTRUMENT: the President of the Republic

DELIVERY METHOD: Notification

QUALITY SUPERVISOR: the Director of Human Resource

PROCESSING: cf. processing chain: PROCEDURE No. 15/MINDEF/PR/PPM/ I
PUTTING AN OFFICER ON INACTIVE STATUS

PROCEDURE No. 17/MINDEF/DRH/PPM/I
TERMINATION OF MILITARY STATUS OF AN OFFICER

TITLE OF THE INSTRUMENT: Decree to terminate the military status of an officer

INITIATOR OF THE PROCEDURE: Administration/Applicant

INITIATING ENTITY: Chief of Staff

PLACE OF SUBMISSION OF FILE: Assignment unit

REFERENCE INSTRUMENTS:

- Law No. 67/LF/9 of 12 June 1967 on the general organisation of Defence;
- Law No. 80/12 of 14 July 1980 on general rules and regulations governing servicemen;
- Decree No. 80/257 of 15 July 1980 to lay down general rules and regulations governing the remuneration schemes applicable to military personnel of the Armed Forces, amended by Decree No. 84/926 of 30 July 1984;
- Decree No. 2001/178 of 25 July 2001 on the general organisation of Defence and Central Staff;
- Decree No. 2001/188 of 25 July 2001 to lay down special rules and regulations governing the corps of Active Officers of the Defence Forces;
- Decree No. 2011/408 of 09 December 2011 to organise the Government;
- Decree No. 2011/412 of 09 December 2011 to reorganise the Presidency of the Republic;
- Decree No. 2012/386 of 14 September 2012 to amend Decree No. 2001/177 of 25 July 2001 to organise the Ministry of Defence;
- Decree No. 2007/199 of 07 July 2007 to lay down Rules of General Discipline in the Defence Forces.

REQUIREMENTS:

- should have resigned;
- should have lost his/her rank (loss of Cameroonian nationality, conviction for a criminal offence, unsuspended prison sentence, dismissal by judgment, revocation).

CONSTITUTION OF FILE:

*** Required documents:**

- letter of resignation;
- committal order;
- demotion order.

*** Reference documents:**

DEADLINE: Thirty (30) days

SIGNATORY OF THE INSTRUMENT: the President of the Republic

DELIVERY METHOD: Notification

QUALITY SUPERVISOR: the Director of Human Resource

PROCESSING: cf. **processing chain:** PROCEDURE No. 15/MINDEF/PR/PPM/ I
PUTTING AN OFFICER ON INACTIVE STATUS

PROCEDURE No. 18/MINDEF/DRH/PPM/I
PLACING A GENERAL IN THE SECOND SECTION

TITLE OF THE INSTRUMENT: Decree to place a general in the second section

INITIATOR OF THE PROCEDURE: Administration

INITIATING ENTITY: President of the Republic

REFERENCE INSTRUMENTS:

- Law No. 67/LF/9 of 12 June 1967 on the general organisation of Defence;
- Law No. 80/12 of 14 July 1980 on general rules and regulations governing servicemen;
- Decree No. 80/257 of 15 July 1980 to lay down general rules and regulations governing the remuneration schemes applicable to military personnel of the Armed Forces, amended by Decree No. 84/926 of 30 July 1984;
- Decree No. 2001/178 of 25 July 2001 on the general organisation of Defence and Central Staff;
- Decree No. 2001/180 of 25 July 2011 to reorganise the Military Territorial Command;
- Decree No. 2001/188 of 25 July 2001 to lay down special rules and regulations governing the corps of Active Officers of the Defence Forces;
- Decree No. 2011/408 of 09 December 2011 to organise the Government;
- Decree No. 2011/412 of 09 December 2011 to reorganise the Presidency of the Republic;
- Decree No. 2012/386 of 14 September 2012 to amend Decree No. 2001/177 of 25 July 2001 to organise the Ministry of Defence;
- Decree No. 2007/199 of 07 July 2007 to lay down Rules of General Discipline in the Defence Forces.

PLACE OF SUBMISSION OF FILE: Assignment unit

REQUIREMENTS:

- should have reached the age limit;
- be withdrawn from employment;
- be sick.

CONSTITUTION OF FILE:

*** Required documents:**

- employment withdrawal document;
- medical record.

*** Reference documents:**

DEADLINE: Fifteen (15) days

SIGNATORY OF THE INSTRUMENT: the President of the Republic

RESOURCE PERSON: the Director of Human Resource

PROCESSING: cf. **processing chain:** *PROCEDURE No. 15/MINDEF/PR/PPM/I*
PUTTING AN OFFICER ON INACTIVE STATUS

PROCEDURE No. 19/MINDEF/DRH/PPM/I
GRANTING RETIREMENT BENEFITS TO AN OFFICER

TITLE OF THE INSTRUMENT: Decree to place some officers of the Defence Forces on retirement for age-related reasons and to grant the payment of their retirement benefits from the mobilisable reserve

INITIATOR OF THE PROCEDURE: Administration

INITIATING ENTITY: Personnel Movements Service

REFERENCE INSTRUMENTS:

- Constitution;
- Law No. 67/LF/9 of 12 June 1967 on the general organisation of Defence;
- Law No. 80/12 of 14 July 1980 on general rules and regulations governing servicemen;
- Decree No. 2001/177 of 25 July 2001 to organise the Ministry of Defence, together with all the amendments thereto;
- Decree No. 2001/188 of 25 July 2001 to lay down special rules and regulations governing the corps of Active Officers of the Defence Forces;
- Decree No. 2004/059 of 23 March 2004 to organise the mobilisable reserve of Active Officers of the Defence Forces;
- Decree No. 2010/382 of 22 December 2010 amending certain provisions of Decree No. 2001/188 of 25 July 2001 to lay down special rules and regulations governing the corps of Active Officers of the Defence Forces;
- Order No. 702/CAB/PR of 25 October 2006 to lay down rules of employment for Active Officers admitted to the mobilisable reserve.

PLACE OF SUBMISSION OF FILE: Assignment unit

REQUIREMENT: Be an officer who has reached the age limit for retirement.

CONSTITUTION OF FILE:

▪ **Required documents:**

▪ **Reference documents:**

- military service record;
- staff file.







DEADLINE: Thirty (30) days

SIGNATORY OF THE INSTRUMENT: the President of the Republic

DELIVERY METHOD: Collection

QUALITY SUPERVISOR: the Director of Human Resource

PROCESSING

DEPARTMENT OF HUMAN RESOURCE	<p><i>PROCEDURE No.</i> <i>19/MINDEF/DRH/PPM/I</i></p> <p><u>GRANTING RETIREMENT BENEFITS TO AN OFFICER</u></p>	Deadline	<p>Procedure start date: 2023</p> <p>Procedure version: 1.0</p> <p>Page</p>
<i>Intervening parties</i>	<i>Stages</i>		<i>Handling rules</i>
 Staff/Secretariat of State for Defence  Director of Human Resource  Head of Personnel Movements Service  Head of Military Personnel Management Bureau  Head of Personnel Movements Service  Head of Personnel Movements Service	<p style="text-align: center;">Beginning</p> <p>- Initiates the file - Forwards the file to the Department of Human Resource</p> <p>- Receives the physical file - Reviews - Assigns the file</p> <p>- Receives the physical file - Checks data conformity - Assigns the file</p> <p>- Receives the physical file through the chain of command - Registers the file - Checks compliance of the physical file - Initiates the draft instrument and the forwarding slip - Forwards the file</p> <p>- Receives the physical file - Checks data conformity - Initiates the draft instrument and the forwarding slip - Forwards the file</p> <p>- Receives the physical file - Checks data conformity - Initiates the draft instrument and the forwarding slip - Forwards the file</p>		<p>R1: Ensure that the file is complete</p> <p>R2: Check the consistency and conformity of documents in the file</p> <p>R3: Ensure that the candidate is eligible</p>

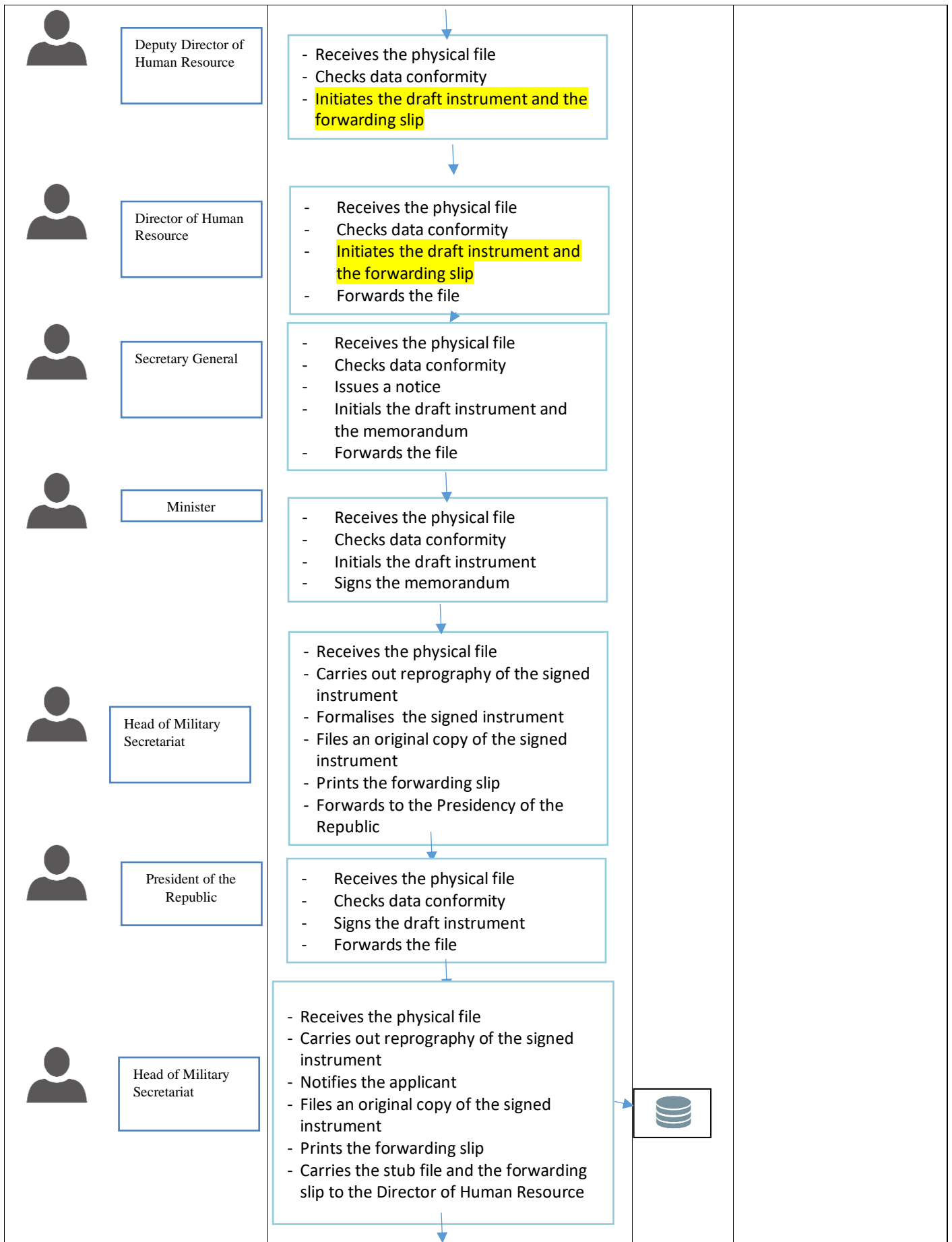

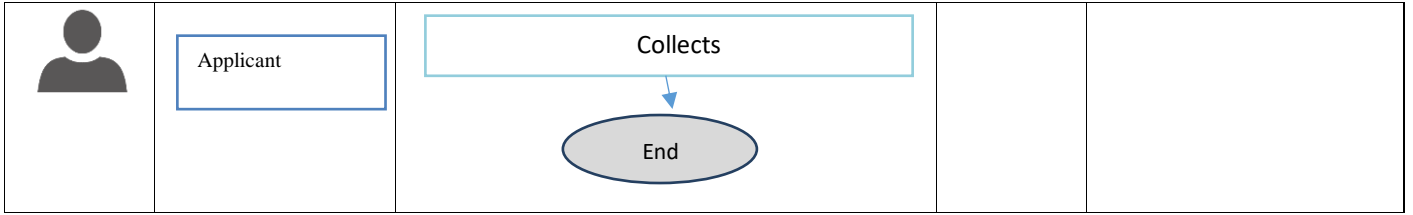

**PROCEDURE No. 20/MINDEF/DRH/PPM/I
PLACING A NON-COMMISSIONED SERVICE MEMBER ON
RETIREMENT**

TITLE OF THE INSTRUMENT: Decree to place some officers of the Defence Forces on retirement for age-related reasons and to grant the payment of their retirement benefits from the mobilisable reserve

INITIATOR OF THE PROCEDURE: Administration

INITIATING ENTITY: Personnel Movements Service

PLACE OF SUBMISSION OF FILE: Assignment unit

REFERENCE INSTRUMENTS:

- Constitution;
- Law No. 67/LF/9 of 12 June 1967 on the general organisation of Defence;
- Law No. 80/12 of 14 July 1980 on general rules and regulations governing servicemen, amended by the provisions of Law No. 87/023 of 17 December 1987;
- Decree No. 76/460 of 12 October 1976 to organise military pension schemes based on longevity of service and invalidity pensions;
- Decree No. 2001/177 of 25 July 2001 to organise the Ministry of Defence, together with all the amendments thereto;
- Decree No. 2001/194 of 25 July 2001 to amend and supplement certain provisions of Decree No. 921/133 of 22 February 1991 to regulate the payment from the State budget of mission and transport costs for military personnel in the event of administrative assignment, scholarship, training, mission, tour, site visit, leave, retirement and death;
- Decree No. 2001/219 of 06 August 2001 to lay down special rules and regulations governing non-commissioned officers of the Defence Forces;
- Decree No. 2004/056 of 23 March 2004 to organise the mobilisable reserve of non-commissioned officers of the Defence Forces;
- Decree No. 2010/382 of 22 December 2010 to amend certain provisions of Decree No. 2001/219 of 06 August 2001 to lay down special rules and regulations governing non-commissioned officers of the Defence Forces;
- Decree No. 2011/412 of 09 December 2011 to reorganise the Presidency of the Republic;
- Decree No. 2012/386 of 14 September 2012 to amend the provisions of Decree No. 2001/177 of 25 July 2001 to organise the Ministry of Defence, together with all the amendments thereto;
- Decree No. 2015/434 of 02 October 2015 to reshuffle the Government;
- Decree No. 2018/148 of 21 February 2018 to amend Decree No. 2014/308 of 14 August 2014 to amend Decree No. 2001/180 of 25 July 2001 to reorganise the Military Territorial Command.

REQUIREMENT: Be an officer who has reached the age limit for retirement.

CONSTITUTION OF FILE:

▪ **Required documents:**

▪ **Reference documents:**

- military service record;
- staff file







DEADLINE: Thirty (30) days

SIGNATORY OF THE INSTRUMENT: the Minister

DELIVERY METHOD: Collection

QUALITY SUPERVISOR: the Director of Human Resource

PROCESSING

DEPARTMENT OF HUMAN RESOURCE	<p><i>PROCEDURE No.</i> <i>20/MINDEF/DRH/PPM/I</i></p> <p><u>PLACING A NON-COMMISSIONED SERVICE MEMBER ON RETIREMENT</u></p>	Deadline	<p>Procedure start date: 2023</p> <p>Procedure version: 1.0</p> <p>Page</p>
<i>Intervening parties</i>	<i>Stages</i>		<i>Handling rules</i>
 Staff/Secretariat of State for Defence  Director of Human Resource  Head of Personnel Movements Service  Head of Military Personnel Management Bureau  Head of Personnel Movements Service  Head of Personnel Movements Service	<p style="text-align: center;">Beginning</p> <p>- Initiates the file - Forwards the file to the Department of Human Resource</p> <p>- Receives the physical file - Reviews - Assigns the file</p> <p>- Receives the physical file - Checks data conformity - Assigns the file</p> <p>- Receives the physical file through the chain of command - Registers the file - Checks compliance of the physical file - Initiates the draft instrument and the forwarding slip - Forwards the file</p> <p>- Receives the physical file - Checks data conformity - Initials the draft instrument and the forwarding slip - Forwards the file</p> <p>- Receives the physical file - Checks data conformity - Initials the draft instrument and the forwarding slip - Forwards the file</p>		<p>R1: Ensure that the file is complete</p> <p>R2: Check the consistency and conformity of documents in the file</p> <p>R3: Ensure that the candidate is eligible</p>

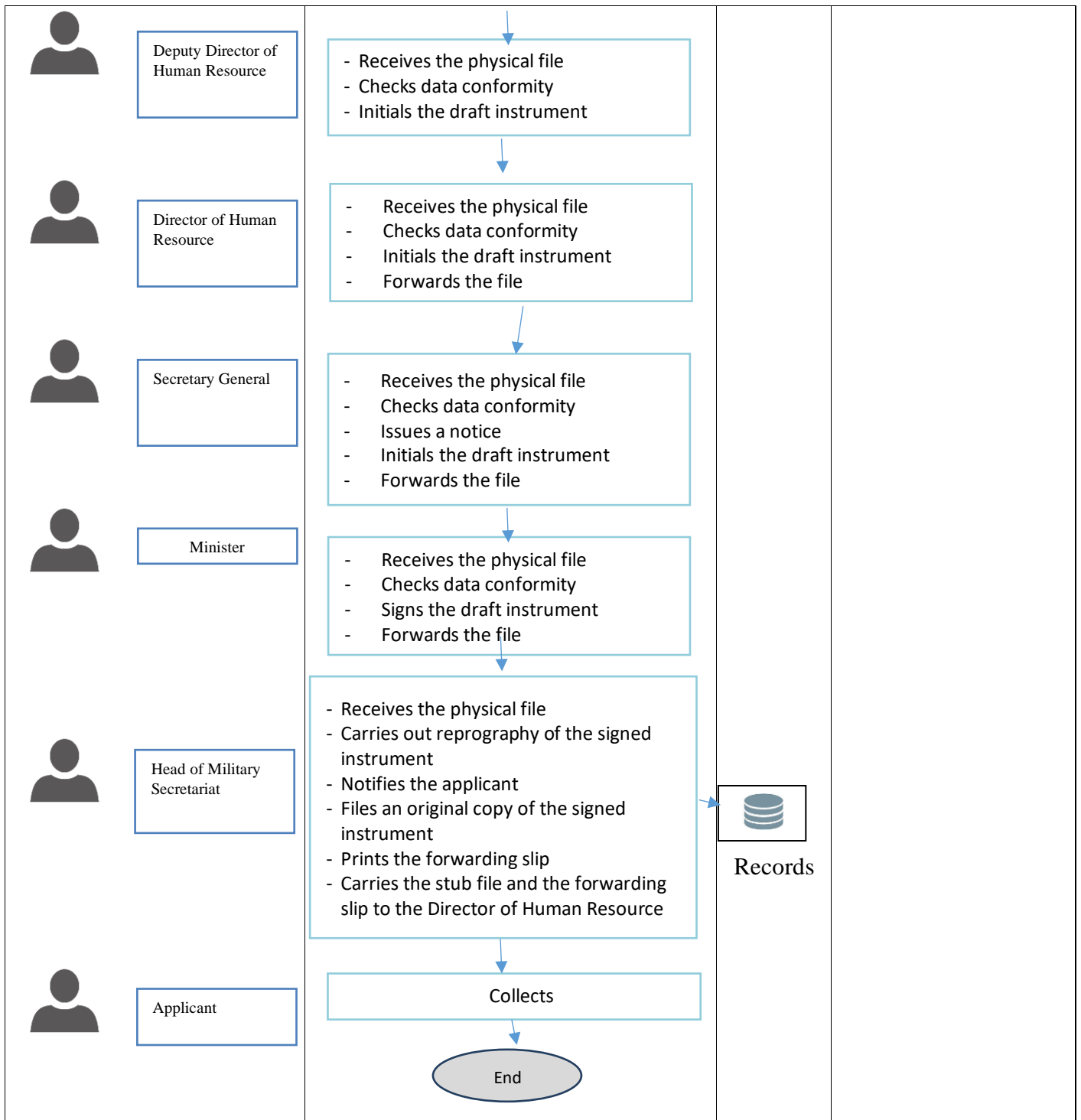

CHIEF OF DEFENCE STAFF

PROCEDURE No. 21/MINDEF/CCA/PPM/I
**GRANTING A 30-DAY EXTENDED LEAVE PASS TO AN
OFFICER**

TITLE OF THE INSTRUMENT: Thirty-day extended leave pass to an officer

INITIATOR OF THE PROCEDURE: Applicant

INITIATING ENTITY: Chief of Staff

PLACE OF SUBMISSION OF FILE: Assignment unit

REFERENCE INSTRUMENTS:

- Law No. 67/LF/9 of 12 June 1967 on the general organisation of Defence;
- Law No. 80/12 of 14 July 1980 on general rules and regulations governing servicemen;
- Decree No. 80/257 of 15 July 1980 to lay down general rules and regulations governing the remuneration schemes applicable to military personnel of the Armed Forces, amended by Decree No. 84/926 of 30 July 1984;
- Decree No. 2001/178 of 25 July 2001 on the general organisation of Defence and Central Staff;
- Decree No. 2001/188 of 25 July 2001 to lay down special rules and regulations governing the corps of Active Officers of the Defence Forces;
- Decree No. 2001/219 of 06 August 2001 to lay down special rules and regulations governing non-commissioned officers of the Defence Forces;
- Decree No. 2011/408 of 09 December 2011 to organise the Government;
- Decree No. 2011/412 of 09 December 2011 to reorganise the Presidency of the Republic;
- Decree No. 2012/386 of 14 September 2012 to amend Decree No. 2001/177 of 25 July 2001 to organise the Ministry of Defence;
- Decree No. 2007/199 of 07 July 2007 to lay down Rules of General Discipline in the Defence Forces.

REQUIREMENTS:

- should have completed at least six (06) months of service;
- Be approved by the superior.

CONSTITUTION OF FILE:

*** Required documents:**

- application addressed to the **Chief of Defence Staff**;
- all supporting documents.

*** Reference document:** Staff file

DEADLINE: Seven (07) days

SIGNATORIES OF THE INSTRUMENT:





- Secretaries of State;
- Chief of Defence Staff;
- Chief of Army Staff;
- Chief of Navy Staff;
- Chief of Staff of the Special Command Post at the Presidency of the Republic;

- Commander of the National Fire Brigade.

DELIVERY METHOD: Notification

QUALITY SUPERVISOR: the Chief of Defence Staff

PROCESSING

CHIEF OF DEFENCE STAFF		PROCEDURE No. 21/MINDEF/CCA/PPM/I GRANTING A 30-DAY EXTENDED LEAVE PASS TO AN OFFICER	Deadline	Procedure start date: 2023
				Procedure version: 1.0
				Page
Intervening parties		Stages		Handling rules
	<div style="border: 1px solid black; padding: 5px; width: fit-content;">Applicant</div>	<div style="border: 1px solid black; border-radius: 50%; padding: 5px; display: inline-block;">Beginning</div> ↓		R1: Ensure that the file is complete
	<div style="border: 1px solid black; padding: 5px; width: fit-content;">Assignment Unit Head</div>	<div style="border: 1px solid black; padding: 5px; width: fit-content;">Submits the file</div> ↓		R2: Check the consistency and conformity of documents in the file
	<div style="border: 1px solid black; padding: 5px; width: fit-content;">Secretariat of the relevant company</div>	<div style="border: 1px solid black; padding: 5px;"> - Receives the physical file through the chain of command - Registers the file - Checks compliance of the physical file - Forwards the file to the relevant company </div> ↓		R3: Ensure that the candidate is eligible
	<div style="border: 1px solid black; padding: 5px; width: fit-content;">Relevant Chief of Staff</div>	<div style="border: 1px solid black; padding: 5px;"> - Receives the physical file through the chain of command - Registers the file - Checks compliance of the physical file - Forwards the file to the Chief of Staff through the chain of command </div> ↓		
	<div style="border: 1px solid black; padding: 5px; width: fit-content;">Relevant Head of Human Resource Bureau</div>	<div style="border: 1px solid black; padding: 5px;"> - Receives the physical file through the chain of command - Checks compliance of the physical file - Initiates the draft instrument - Forwards the file to the Chief of Staff through the chain of command </div> ↓		

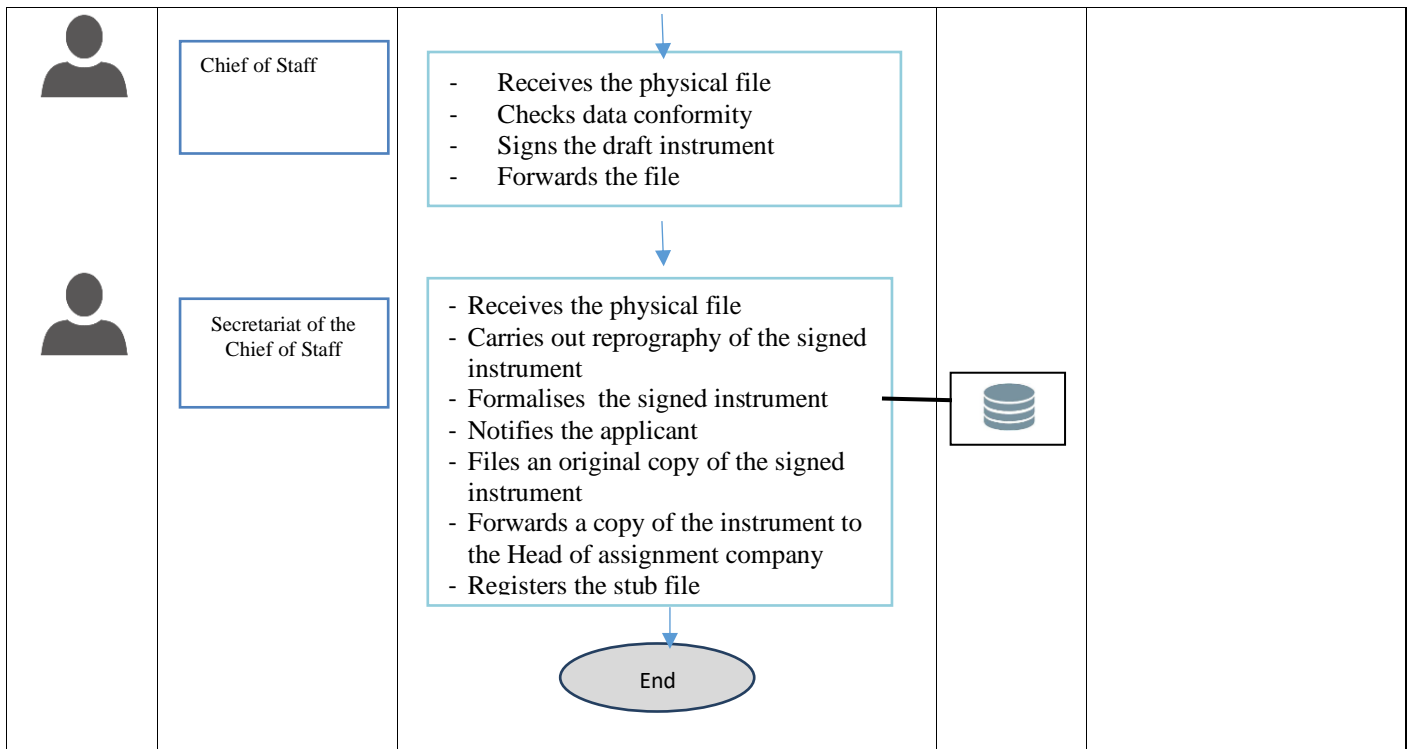

COMPANY

**PROCEDURE No. 22/MINDEF/DRH/PPM/I
GRANTING A 30-DAY EXTENDED LEAVE PASS TO A NON-
COMMISSIONED SERVICE MEMBER**

TITLE OF THE INSTRUMENT: Thirty-day extended leave pass to a non-commissioned service member

INITIATOR OF THE PROCEDURE: Applicant

INITIATING ENTITY: Personnel Movements Service

PLACE OF SUBMISSION OF FILE: Assignment unit

REFERENCE INSTRUMENTS:

- Law No. 67/LF/9 of 12 June 1967 on the general organisation of Defence;
- Law No. 80/12 of 14 July 1980 on general rules and regulations governing servicemen;
- Decree No. 80/257 of 15 July 1980 to lay down general rules and regulations governing the remuneration schemes applicable to military personnel of the Armed Forces, amended by Decree No. 84/926 of 30 July 1984;
- Decree No. 2001/178 of 25 July 2001 on the general organisation of Defence and Central Staff;
- Decree No. 2001/219 of 06 August 2001 to lay down special rules and regulations governing non-commissioned officers of the Defence Forces;
- Decree No. 2011/408 of 09 December 2011 to organise the Government;
- Decree No. 2011/412 of 09 December 2011 to reorganise the Presidency of the Republic;
- Decree No. 2012/386 of 14 September 2012 to amend Decree No. 2001/177 of 25 July 2001 to organise the Ministry of Defence;
- Decree No. 2007/199 of 07 July 2007 to lay down Rules of General Discipline in the Defence Forces.

REQUIREMENTS:

- should have completed at least six (06) months of service;
- be approved by the superior.

CONSTITUTION OF FILE:

*** Required documents:**

- application addressed to the Head of Department;
- all supporting documents.





*** Reference documents:**

DEADLINE: Seven (07) days

SIGNATORY OF THE INSTRUMENT: the Company Commander

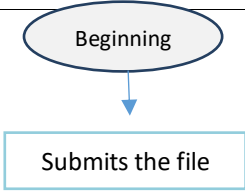
DELIVERY METHOD: Notification

QUALITY SUPERVISOR: the Company Commander

COMPANY		PROCEDURE No. 22/MINDEF/C/PPM/ I <u>GRANTING A 30-DAY EXTENDED LEAVE PASS TO A NON- COMMISSIONED SERVICE MEMBER</u>	Deadline	Procedure start date: 2023 Procedure version: 1.0 Page
Intervening parties		Stages		Handling rules
	Applicant			
	Relevant Company Warrant Officer	<ul style="list-style-type: none"> - Receives the physical file through the chain of command - Registers the file - Checks compliance of the physical file - Forwards the file 		R1: Ensure that the file is complete R2: Check the consistency and conformity of documents in the file
	Head of Secretariat	<ul style="list-style-type: none"> - Receives the physical file through the chain of command - Registers the file - Checks compliance of the physical file - Initiates the draft instrument - Forwards the file 		
	Relevant Company Commander	<ul style="list-style-type: none"> - Receives the physical file through the chain of command - Checks compliance of the physical file - Signs the draft instrument - Forwards the file 		
	Head of Secretariat	<ul style="list-style-type: none"> - Receives the physical file - Carries out reprography of the signed instrument - Formalises the signed instrument - Notifies the applicant - Files an original copy of the signed instrument 		

SUPERIOR

PROCEDURE No. 23MINDEF/SH/PPM/ 1
**ISSUING AN ATTESTATION OF EFFECTIVE PRESENCE
TO AN OFFICER**

TITLE OF THE INSTRUMENT: Attestation of effective presence to an officer

INITIATOR OF THE PROCEDURE: Applicant

INITIATING ENTITY: Personnel Service

PLACE OF SUBMISSION OF FILE: Assignment unit

REFERENCE INSTRUMENTS:

- Law No. 67/LF/9 of 12 June 1967 on the general organisation of Defence;
- Law No. 80/12 of 14 July 1980 on general rules and regulations governing servicemen;
- Decree No. 80/257 of 15 July 1980 to lay down general rules and regulations governing the remuneration schemes applicable to military personnel of the Armed Forces, amended by Decree No. 84/926 of 30 July 1984;
- Decree No. 2001/178 of 25 July 2001 on the general organisation of Defence and Central Staff;
- Decree No. 2001/188 of 25 July 2001 to lay down special rules and regulations governing the corps of Active Officers of the Defence Forces;
- Decree No. 2001/219 of 06 August 2001 to lay down special rules and regulations governing non-commissioned officers of the Defence Forces;
- Decree No. 2011/408 of 09 December 2011 to organise the Government;
- Decree No. 2011/412 of 09 December 2011 to reorganise the Presidency of the Republic;
- Decree No. 2012/386 of 14 September 2012 to amend Decree No. 2001/177 of 25 July 2001 to organise the Ministry of Defence;
- Decree No. 2007/199 of 07 July 2007 to lay down Rules of General Discipline in the Defence Forces.

REQUIREMENTS: Be regular at service.

CONSTITUTION OF FILE:

* *Required document:* Unstamped handwritten application addressed to the Service Head

* *Reference document:* Arms record (SPA)







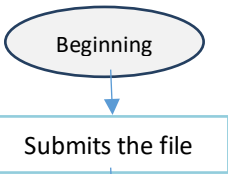

DEADLINE: Seven (07) days

SIGNATORY OF THE INSTRUMENT: the Service Head

DELIVERY METHOD: Notification

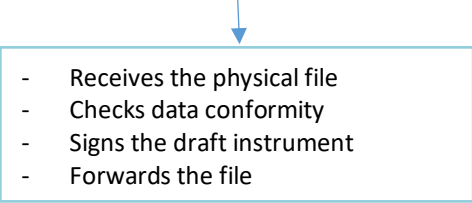
QUALITY SUPERVISOR: the Service Head

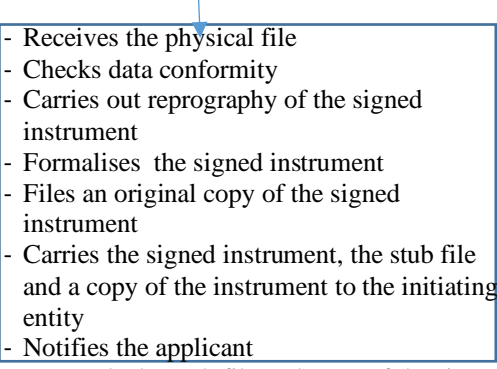
PROCESSING

SUPERIOR		Procedure No. 23/ MINDEF <u>ISSUING AN ATTESTATION OF EFFECTIVE PRESENCE TO AN OFFICER</u>	Deadline	Procedure start date: 2023
				Procedure version: 1.0
				Page
Intervening parties		Stages		Handling rules
	Applicant			
	Mail Bureau (Mail Bureau Head, First Secretary, MAGE Secretary, etc.)	<ul style="list-style-type: none"> - Receives the physical file - Checks compliance of the physical file - Registers the file - Forwards the file 		R1: Ensure that the file is complete R2: Check the consistency and conformity of documents in the file
	Personnel Service (Officer Affairs Bureau, etc.)	<ul style="list-style-type: none"> - Receives the physical file - Reviews the physical file - Initiates the draft instrument - Forwards the physical file through the chain of command 		
	Competent authorities (Secretariat of State for Defence, Chiefs of Staff of the various Armed Forces, Directors and persons ranking as such)	 <ul style="list-style-type: none"> - Receives the physical file - Checks data conformity - Signs the draft instrument - Forwards the file 		
	Mail Bureau of the Chief Signatory	 <ul style="list-style-type: none"> - Receives the physical file - Checks data conformity - Carries out reprography of the signed instrument - Formalises the signed instrument - Files an original copy of the signed instrument - Carries the signed instrument, the stub file and a copy of the instrument to the initiating entity - Notifies the applicant - Forwards the stub file and copy of the signed instrument for filing - Files a copy. 		

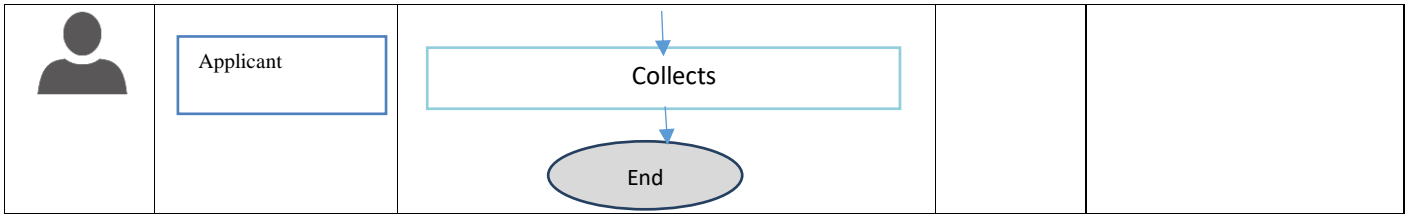

**PROCEDURE No. 24/MINDEF/SH/PPM/I
ISSUING A MISSION ORDER**

TITLE OF THE INSTRUMENT: Mission order

INITIATOR OF THE PROCEDURE: Administration

INITIATING ENTITY: Personnel Service

REFERENCE INSTRUMENTS:

- Law No. 67/LF/9 of 12 June 1967 on the general organisation of Defence;
- Law No. 80/12 of 14 July 1980 on general rules and regulations governing servicemen;
- Decree No. 80/257 of 15 July 1980 to lay down general rules and regulations governing the remuneration schemes applicable to military personnel of the Armed Forces, amended by Decree No. 84/926 of 30 July 1984;
- Decree No. 2001/178 of 25 July 2001 on the general organisation of Defence and Central Staff;
- Decree No. 2001/188 of 25 July 2001 to lay down special rules and regulations governing the corps of Active Officers of the Defence Forces;
- Decree No. 2001/219 of 06 August 2001 to lay down special rules and regulations governing non-commissioned officers of the Defence Forces;
- Decree No. 2011/408 of 09 December 2011 to organise the Government;
- Decree No. 2011/412 of 09 December 2011 to reorganise the Presidency of the Republic;
- Decree No. 2012/386 of 14 September 2012 to amend Decree No. 2001/177 of 25 July 2001 to organise the Ministry of Defence;
- Decree No. 2007/199 of 07 July 2007 to lay down Rules of General Discipline in the Defence Forces.

PLACE OF SUBMISSION OF FILE: Assignment unit

REQUIREMENTS: Be designated for a mission.

CONSTITUTION OF FILE:

* **Required document:** Recent payslip

* **Reference document:** Document organising the mission

DEADLINE: Seven (07) days

SIGNATORY OF THE INSTRUMENT: the Superior

DELIVERY METHOD: Notification

QUALITY SUPERVISOR: the Superior

**PROCESSING: cf. processing chain: Procedure No. 23/ MINDEF/SH/PPM/I
ISSUING AN ATTESTATION OF EFFECTIVE PRESENCE TO AN OFFICER**

**PROCEDURE No. 25/MINDEF/SH/PPM/I
ISSUING A CASUAL LEAVE PASS**

TITLE OF THE INSTRUMENT: Casual leave pass

INITIATOR OF THE PROCEDURE: Applicant

INITIATING ENTITY: Personnel Service

PLACE OF SUBMISSION OF FILE: Assignment unit

REFERENCE INSTRUMENTS:

- Law No. 67/LF/9 of 12 June 1967 on the general organisation of Defence;
- Law No. 80/12 of 14 July 1980 on general rules and regulations governing servicemen;
- Decree No. 80/257 of 15 July 1980 to lay down general rules and regulations governing the remuneration schemes applicable to military personnel of the Armed Forces, amended by Decree No. 84/926 of 30 July 1984;
- Decree No. 2001/178 of 25 July 2001 on the general organisation of Defence and Central Staff;
- Decree No. 2001/188 of 25 July 2001 to lay down special rules and regulations governing the corps of Active Officers of the Defence Forces;
- Decree No. 2001/219 of 06 August 2001 to lay down special rules and regulations governing non-commissioned officers of the Defence Forces;
- Decree No. 2011/408 of 09 December 2011 to organise the Government;
- Decree No. 2011/412 of 09 December 2011 to reorganise the Presidency of the Republic;
- Decree No. 2012/386 of 14 September 2012 to amend Decree No. 2001/177 of 25 July 2001 to organise the Ministry of Defence;
- Decree No. 2007/199 of 07 July 2007 to lay down Rules of General Discipline in the Defence Forces.

REQUIREMENT: Be approved by the immediate superior.

CONSTITUTION OF FILE:

*** Required documents:**

- application addressed to the Superior;
- all supporting documents.

*** Reference documents:**

- staff file;
- arms record (SPA).

DEADLINE: Seven (07) days

SIGNATORY OF THE INSTRUMENT: the Service Head

DELIVERY METHOD: Notification

QUALITY SUPERVISOR: The Superior

**PROCESSING: cf. processing chain: Procedure No. 23/ MINDEF/SH/PPM/I
ISSUING AN ATTESTATION OF EFFECTIVE PRESENCE TO AN OFFICER**

PROCEDURE No. 26/MINDEF/SH/PPM/I
ISSUING A SHORT-TERM CASUAL LEAVE PASS

TITLE OF THE INSTRUMENT: Casual leave pass

INITIATOR OF THE PROCEDURE: Applicant

INITIATING ENTITY: Personnel Service

PLACE OF SUBMISSION OF FILE: Assignment unit

REFERENCE INSTRUMENTS:

- Law No. 67/LF/9 of 12 June 1967 on the general organisation of Defence;
- Law No. 80/12 of 14 July 1980 on general rules and regulations governing servicemen;
- Decree No. 80/257 of 15 July 1980 to lay down general rules and regulations governing the remuneration schemes applicable to military personnel of the Armed Forces, amended by Decree No. 84/926 of 30 July 1984;
- Decree No. 2001/178 of 25 July 2001 on the general organisation of Defence and Central Staff;
- Decree No. 2001/188 of 25 July 2001 to lay down special rules and regulations governing the corps of Active Officers of the Defence Forces;
- Decree No. 2001/219 of 06 August 2001 to lay down special rules and regulations governing non-commissioned officers of the Defence Forces;
- Decree No. 2011/408 of 09 December 2011 to organise the Government;
- Decree No. 2011/412 of 09 December 2011 to reorganise the Presidency of the Republic;
- Decree No. 2012/386 of 14 September 2012 to amend Decree No. 2001/177 of 25 July 2001 to organise the Ministry of Defence;
- Decree No. 2007/199 of 07 July 2007 to lay down Rules of General Discipline in the Defence Forces.

REQUIREMENT: Be approved by the superior.

CONSTITUTION OF FILE:

** Required document:*

- application addressed to the Superior;
- all supporting documents.

** Reference documents:* Staff file

DEADLINE: One (01) week

SIGNATORY OF THE INSTRUMENT: the Service Head for all incremental positions

DELIVERY METHOD: Notification

QUALITY SUPERVISOR: The Superior

PROCESSING: cf. processing chain: Procedure No. 23/ MINDEF/SH/PPM/I
ISSUING AN ATTESTATION OF EFFECTIVE PRESENCE TO AN OFFICER

**PROCEDURE No. 27/MINDEF/SH/PPM/I
ISSUING A SPECIAL CASUAL LEAVE PASS**

TITLE OF THE INSTRUMENT: Special casual leave pass

INITIATOR OF THE PROCEDURE: Applicant

INITIATING ENTITY: Personnel Service

PLACE OF SUBMISSION OF FILE: Assignment unit

REFERENCE INSTRUMENTS:

- Law No. 67/LF/9 of 12 June 1967 on the general organisation of Defence;
- Law No. 80/12 of 14 July 1980 on general rules and regulations governing servicemen;
- Decree No. 80/257 of 15 July 1980 to lay down general rules and regulations governing the remuneration schemes applicable to military personnel of the Armed Forces, amended by Decree No. 84/926 of 30 July 1984;
- Decree No. 2001/178 of 25 July 2001 on the general organisation of Defence and Central Staff;
- Decree No. 2001/188 of 25 July 2001 to lay down special rules and regulations governing the corps of Active Officers of the Defence Forces;
- Decree No. 2001/219 of 06 August 2001 to lay down special rules and regulations governing non-commissioned officers of the Defence Forces;
- Decree No. 2011/408 of 09 December 2011 to organise the Government;
- Decree No. 2011/412 of 09 December 2011 to reorganise the Presidency of the Republic;
- Decree No. 2012/386 of 14 September 2012 to amend Decree No. 2001/177 of 25 July 2001 to organise the Ministry of Defence;
- Decree No. 2007/199 of 07 July 2007 to lay down Rules of General Discipline in the Defence Forces.

REQUIREMENTS:

- have a ceremony for the main religious festivals or take part in an important or serious family event such as a wedding, birth or death of a relative;
- be approved by the superior.

CONSTITUTION OF FILE:

*** Required documents:**

- application addressed to the Superior;
- all supporting documents.

*** Reference documents:** Staff file

DEADLINE: Seven (07) days

SIGNATORY OF THE INSTRUMENT: the Service Head

DELIVERY METHOD: Collection

QUALITY SUPERVISOR: the Superior

**PROCESSING: cf. processing chain: Procedure No. 23/ MINDEF/SH/PPM/I
ISSUING AN ATTESTATION OF EFFECTIVE PRESENCE TO AN OFFICER**

**PROCEDURE No. 28/MINDEF/DRH/PPM/I
ISSUING A MATERNITY LEAVE PASS**

TITLE OF THE INSTRUMENT: Maternity leave pass

INITIATOR OF THE PROCEDURE: Applicant

INITIATING ENTITY: Chief of Staff

PLACE OF SUBMISSION OF FILE: Assignment unit

REFERENCE INSTRUMENTS:

- Law No. 67/LF/9 of 12 June 1967 on the general organisation of Defence;
- Law No. 80/12 of 14 July 1980 on general rules and regulations governing servicemen;
- Decree No. 80/257 of 15 July 1980 to lay down general rules and regulations governing the remuneration schemes applicable to military personnel of the Armed Forces, amended by Decree No. 84/926 of 30 July 1984;
- Decree No. 2001/178 of 25 July 2001 on the general organisation of Defence and Central Staff;
- Decree No. 2001/188 of 25 July 2001 to lay down special rules and regulations governing the corps of Active Officers of the Defence Forces;
- Decree No. 2001/219 of 06 August 2001 to lay down special rules and regulations governing non-commissioned officers of the Defence Forces;
- Decree No. 2011/408 of 09 December 2011 to organise the Government;
- Decree No. 2011/412 of 09 December 2011 to reorganise the Presidency of the Republic;
- Decree No. 2012/386 of 14 September 2012 to amend Decree No. 2001/177 of 25 July 2001 to organise the Ministry of Defence;
- Decree No. 2007/199 of 07 July 2007 to lay down Rules of General Discipline in the Defence Forces.

REQUIREMENTS:

- be a female service member;
- be pregnant.

CONSTITUTION OF FILE:

*** Required documents:**

- unstamped application addressed to the Minister;
- pregnancy certificate/delivery certificate.

*** Reference document:** Staff file

DEADLINE: Fourteen (14) days

SIGNATORY OF THE INSTRUMENT: the Service Head

DELIVERY METHOD: Collection

QUALITY SUPERVISOR: the Superior

**PROCESSING: cf. processing chain: Procedure No. 23/ MINDEF/SH/PPM/I
ISSUING AN ATTESTATION OF EFFECTIVE PRESENCE TO AN OFFICER**

PROCEDURE No. 29/MINDEF/SH/PPM/I
GRANTING A RELEASE LEAVE TO A NON-COMMISSIONED
SERVICE MEMBER

TITLE OF THE INSTRUMENT: Release leave pass

INITIATOR OF THE PROCEDURE: Applicant

INITIATING ENTITY: Personnel Service

PLACE OF SUBMISSION OF FILE: Assignment unit

REFERENCE INSTRUMENTS:

- Law No. 67/LF/9 of 12 June 1967 on the general organisation of Defence;
- Law No. 80/12 of 14 July 1980 on general rules and regulations governing servicemen;
- Decree No. 80/257 of 15 July 1980 to lay down general rules and regulations governing the remuneration schemes applicable to military personnel of the Armed Forces, amended by Decree No. 84/926 of 30 July 1984;
- Decree No. 2001/178 of 25 July 2001 on the general organisation of Defence and Central Staff;
- Decree No. 2001/188 of 25 July 2001 to lay down special rules and regulations governing the corps of Active Officers of the Defence Forces;
- Decree No. 2001/219 of 06 August 2001 to lay down special rules and regulations governing non-commissioned officers of the Defence Forces;
- Decree No. 2011/408 of 09 December 2011 to organise the Government;
- Decree No. 2011/412 of 09 December 2011 to reorganise the Presidency of the Republic;
- Decree No. 2012/386 of 14 September 2012 to amend Decree No. 2001/177 of 25 July 2001 to organise the Ministry of Defence;
- Decree No. 2007/199 of 07 July 2007 to lay down Rules of General Discipline in the Defence Forces.

REQUIREMENTS:

- be a service member serving under a contract/conversion;
- should have served for at least two months before going on retirement;
- should be retired.

CONSTITUTION OF FILE:

*** Required documents:**

- unstamped application addressed to the Minister;
- retirement decision.

*** Reference document:** Staff file

DEADLINE: Seven (07) days

SIGNATORY OF THE INSTRUMENT: the Service Head

DELIVERY METHOD: Collection

QUALITY SUPERVISOR: the Superior

PROCESSING: cf. processing chain: Procedure No. 23/ MINDEF/SH/PPM/I
ISSUING AN ATTESTATION OF EFFECTIVE PRESENCE TO AN OFFICER

PROCEDURE No. 30/MINDEF/SH/PPM/I
**ISSUING AN AUTHORISATION FOR VEHICLEER
CHANGE TO A NON-COMMISSIONED SERVICE MEMBER**

TITLE OF THE INSTRUMENT: Authorisation for vehicleer change to a non-commissioned service member

INITIATOR OF THE PROCEDURE: Applicant

INITIATING ENTITY: Personnel Service

PLACE OF SUBMISSION OF FILE: Assignment unit

REFERENCE INSTRUMENTS:

- Law No. 67/LF/9 of 12 June 1967 on the general organisation of Defence;
- Law No. 80/12 of 14 July 1980 on general rules and regulations governing servicemen;
- Decree No. 80/257 of 15 July 1980 to lay down general rules and regulations governing the remuneration schemes applicable to military personnel of the Armed Forces, amended by Decree No. 84/926 of 30 July 1984;
- Decree No. 2001/178 of 25 July 2001 on the general organisation of Defence and Central Staff;
- Decree No. 2001/188 of 25 July 2001 to lay down special rules and regulations governing the corps of Active Officers of the Defence Forces;
- Decree No. 2001/219 of 06 August 2001 to lay down special rules and regulations governing non-commissioned officers of the Defence Forces;
- Decree No. 2011/408 of 09 December 2011 to organise the Government;
- Decree No. 2011/412 of 09 December 2011 to reorganise the Presidency of the Republic;
- Decree No. 2012/386 of 14 September 2012 to amend Decree No. 2001/177 of 25 July 2001 to organise the Ministry of Defence;
- Decree No. 2007/199 of 07 July 2007 to lay down Rules of General Discipline in the Defence Forces.

REQUIREMENTS:

- be a vehicleer service member;
- should have served for at least two months before going on retirement;
- should be retired.

CONSTITUTION OF FILE:

*** Required documents:**

- unstamped application addressed to the Service Head;
- retirement decision.

*** Reference document:** Staff file

DEADLINE: Seven (07) days

SIGNATORY OF THE INSTRUMENT: the Service Head

DELIVERY METHOD: Collection

QUALITY SUPERVISOR: the Superior

PROCESSING: cf. processing chain: **Procedure No. 23/ MINDEF/SH/PPM/I
ISSUING AN ATTESTATION OF EFFECTIVE PRESENCE TO AN OFFICER**

PROCEDURE No. 31/MINDEF/SRH/PPM/ I
ISSUING AN END-OF-COURSE CASUAL LEAVE PASS

TITLE OF THE INSTRUMENT: End-of-course casual leave pass

INITIATOR OF THE PROCEDURE: Administration

INITIATING ENTITY: Personnel Service

PLACE OF SUBMISSION OF FILE: Assignment unit

REFERENCE INSTRUMENTS:

- Law No. 67/LF/9 of 12 June 1967 on the general organisation of Defence;
- Law No. 80/12 of 14 July 1980 on general rules and regulations governing servicemen;
- Decree No. 80/257 of 15 July 1980 to lay down general rules and regulations governing the remuneration schemes applicable to military personnel of the Armed Forces, amended by Decree No. 84/926 of 30 July 1984;
- Decree No. 2001/178 of 25 July 2001 on the general organisation of Defence and Central Staff;
- Decree No. 2001/188 of 25 July 2001 to lay down special rules and regulations governing the corps of Active Officers of the Defence Forces;
- Decree No. 2001/219 of 06 August 2001 to lay down special rules and regulations governing non-commissioned officers of the Defence Forces;
- Decree No. 2011/408 of 09 December 2011 to organise the Government;
- Decree No. 2011/412 of 09 December 2011 to reorganise the Presidency of the Republic;
- Decree No. 2012/386 of 14 September 2012 to amend Decree No. 2001/177 of 25 July 2001 to organise the Ministry of Defence;
- Decree No. 2007/199 of 07 July 2007 to lay down Rules of General Discipline in the Defence Forces.

REQUIREMENTS:

- should have undergone a training course.

CONSTITUTION OF FILE:

** Required documents:*

- photocopy of end-of-course certificate/testimonial;
- course admission document;
- re-assignment document signed by the head of the training institution.

** Reference documents:*

DEADLINE: Seven (07) days

SIGNATORY OF THE INSTRUMENT: the Service Head

DELIVERY METHOD: Collection

QUALITY SUPERVISOR: the Superior

PROCESSING: cf. processing chain: **Procedure No. 23/ MINDEF/SH/PPM/I**
ISSUING AN ATTESTATION OF EFFECTIVE PRESENCE TO AN OFFICER

VOLUME 2
PROMOTION OF MILITARY PERSONNEL

PROMOTION PROCEDURES

1. PROMOTION TO THE RANK OF OFFICER
2. ADMISSION TO THE OFFICERS' CORPS AND PROMOTION TO THE RANK OF SUB-LIEUTENANT OR MIDSHIPMAN OF A CHIEF WARRANT OFFICER OR CHIEF PETTY OFFICER
3. ADVANCEMENT IN INCREMENTAL POSITION OF AN OFFICER
4. PROMOTION OF A NON-COMMISSIONED SERVICE MEMBER TO A HIGHER RANK
5. PROMOTION TO THE POSITION OF PRIVATE 1st CLASS AND SEAMAN SECOND CLASS

PROCEDURE No. 01/MINDEF/DRH/PPM/I
PROMOTION TO THE RANK OF OFFICER

TITLE OF THE INSTRUMENT: Decree on promotion to the rank of officer

INITIATOR OF THE PROCEDURE: Administration

INITIATING ENTITY: Advancement Bureau

PLACE OF SUBMISSION OF FILE: Assignment unit

REFERENCE INSTRUMENTS:

- Law No. 67/LF/9 of 12 June 1967 on the general organisation of Defence;
- Law No. 80/12 of 14 July 1980 to lay down general rules and regulations governing servicemen;
- Finance Law of the Republic of Cameroon for the current financial year;
- Decree No. 75/459 of 26 June 1975 to determine the remuneration scheme of civilian and military personnel of the Republic of Cameroon, as amended and supplemented by Decree No. 79/69 of 03 March 1979;
- Decree No. 75/791 of 18 December 1975 to lay down the salary index scale for senior civil servants in Cameroon;
- Decree No. 80/257 of 15 July 1980 to lay down general rules and regulations governing the remuneration schemes applicable to military personnel of the Armed Forces, together with all the amendments thereto;
- Decree No. 2001/177 of 25 July 2001 to organise the Ministry of Defence;
- Decree No. 2001/188 of 25 July 2001 to lay down special rules and regulations governing the corps of Active Officers of the Defence Forces;
- Decree No. 2018/190 of 02 March 2018 amending and supplementing certain provisions of Decree No. 2011/408 of 09 December 2011 to organise the Government;
- Decree No.....to lay down particular/special rules and regulations governing the corps concerned;
- Circular No. /MINFI/ ofon the Instructions relating to the Implementation, Monitoring and Control of the Execution of the State Budget, Public Administrative Institutions, Regional and Local Authorities and other Subsidised Entities, for the current financial year.

REQUIREMENT: Have one (01) year of service in the previous rank.

NB : *For the rank of Sub-Lieutenant to Lieutenant or Midshipman to Sub-Lieutenant:* have two (02) years of service (automatic promotion).

CONSTITUTION OF FILE:

* **Required documents:**

* **Reference documents:**

- proposal brief;
- text of appointment to the previous rank;
- score sheets of the last five years;
- punishment record of the last five years;
- note sheets of the last five years;
- highest military certificate;
- text of appointment to the current rank.

DEADLINE: Six (06) months

SIGNATORY OF THE INSTRUMENT: the President of the Republic

DELIVERY METHOD: Radio-press release/Notification/Collection

QUALITY SUPERVISOR: the Director of Human Resource

PROCESSING

MINISTRY OF DEFENCE	PROCEDURE No. 01/MINDEF/DRH/PPM/I PROMOTION TO THE RANK OF OFFICER	Procedure start date: 2023	
		Deadline	Procedure version: 1.0 Page
Intervening parties	Stages		Handling rules
<p>Applicant</p> <p>Base Company</p> <p>Director of Human Resource</p> <p>Head of Chancellery Service</p> <p>Chief of Advancement Bureau</p> <p>Head of Chancellery Service</p>	<p>Beginning</p> <p>Submits the file</p> <ul style="list-style-type: none"> - Receives the physical file - Checks file's compliance - Reviews - Registers the file - Initiates and signs the forwarding slip and letter - Forwards the physical file to the Director of Human Resource through the chain of command <ul style="list-style-type: none"> - Receives the physical file - Checks file's compliance - Reviews - Assigns the file <ul style="list-style-type: none"> - Receives the physical file - Reviews - Assigns the file <ul style="list-style-type: none"> - Receives the physical file - Reviews - Checks file's compliance - Initiates the draft instrument forwarding letter - Forwards the file <ul style="list-style-type: none"> - Receives the physical file - Reviews - Initials the draft instrument - Forwards the file 		<p>R1: Check file's compliance</p> <p>R2: Ensure the authenticity of the information provided and the availability of places</p>

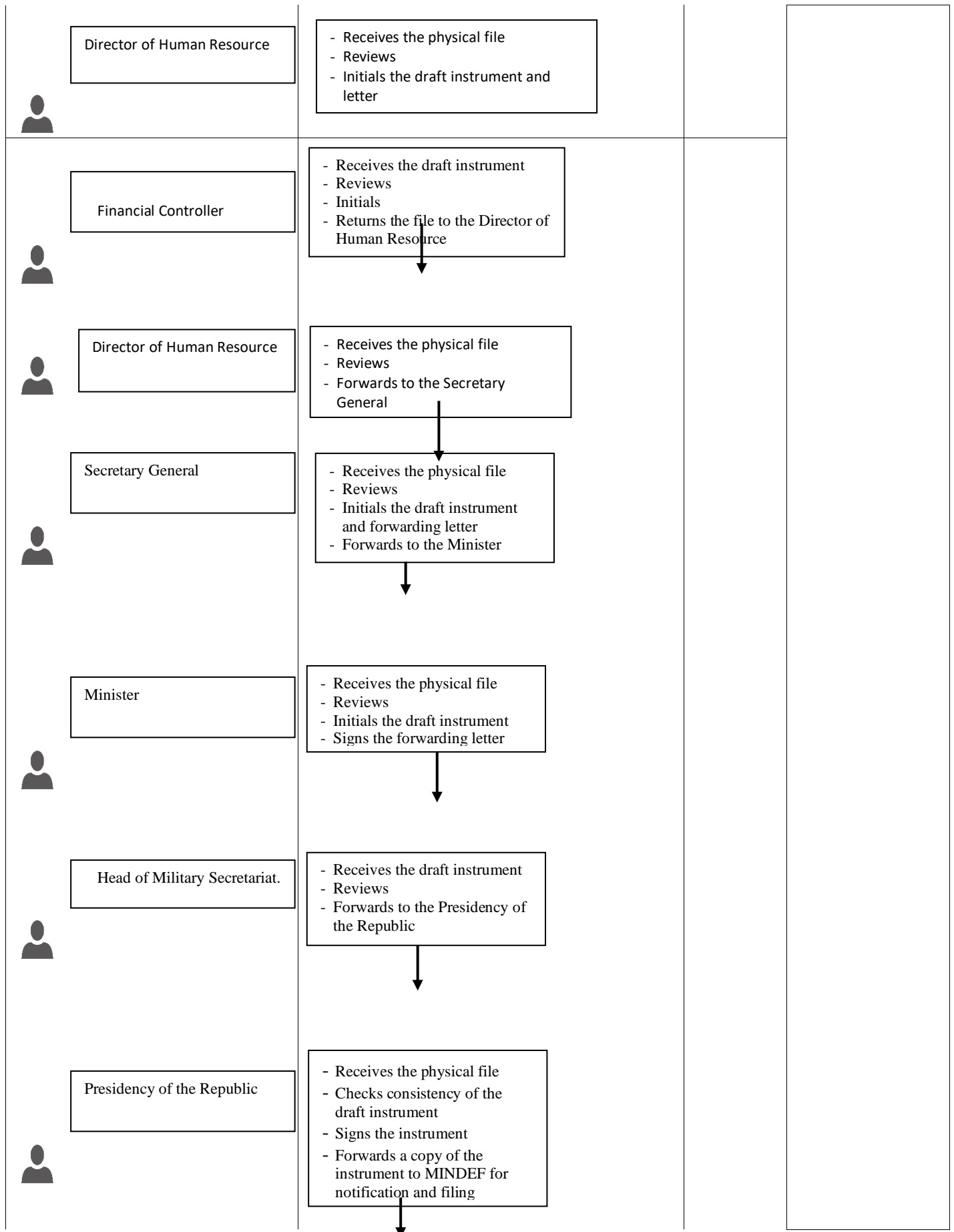

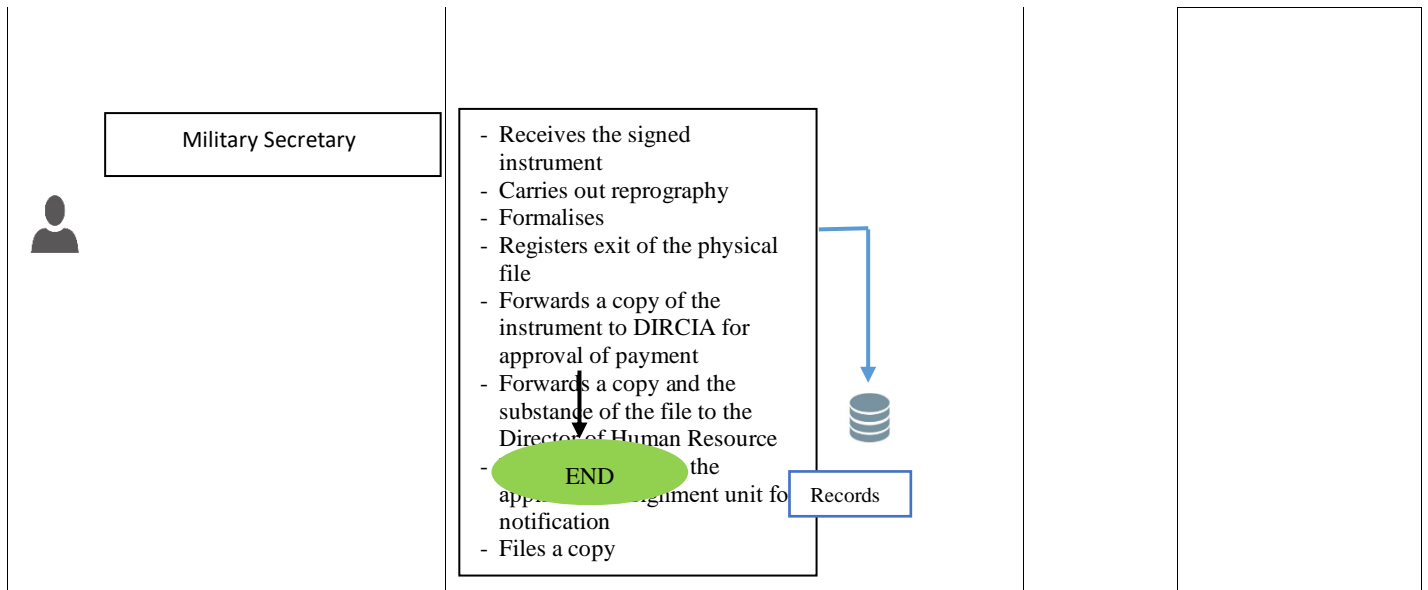

PROCEDURE No. 02/MINDEF/DRH/PPM/1
**ADMISSION TO THE OFFICERS' CORPS AND PROMOTION TO
THE RANK OF SUB-LIEUTENANT OR MIDSHIPMAN OF A CHIEF
WARRANT OFFICER OR CHIEF PETTY OFFICER**

TITLE OF THE INSTRUMENT: Decree on admission to the officers' corps and promotion to the rank of sub-lieutenant or midshipman of a chief warrant officer or chief petty officer

INITIATOR OF THE PROCEDURE: Administration/Applicant

INITIATING ENTITY: Advancement Bureau

REFERENCE INSTRUMENTS:

- Law No. 67/LF/9 of 12 June 1967 on the general organisation of Defence;
- Law No. 80/12 of 14 July 1980 to lay down general rules and regulations governing servicemen;
- Finance Law of the Republic of Cameroon for the current financial year;
- Decree No. 75/459 of 26 June 1975 to determine the remuneration scheme of civilian and military personnel of the Republic of Cameroon, as amended and supplemented by Decree No. 79/69 of 03 March 1979;
- Decree No. 75/791 of 18 December 1975 to lay down the salary index scale for senior civil servants in Cameroon;
- Decree No. 80/257 of 15 July 1980 to lay down general rules and regulations governing the remuneration schemes applicable to military personnel of the Armed Forces, together with all the amendments thereto;
- Decree No. 2001/177 of 25 July 2001 to organise the Ministry of Defence;
- Decree No. 2001/188 of 25 July 2001 to lay down special rules and regulations governing the corps of Active Officers of the Defence Forces;
- Decree No. 2018/190 of 02 March 2018 amending and supplementing certain provisions of Decree No. 2011/408 of 09 December 2011 to organise the Government;
- Decree No.....to lay down particular/special rules and regulations governing the corps concerned;
- Circular No. /MINFI/ ofon the Instructions relating to the Implementation, Monitoring and Control of the Execution of the State Budget, Public Administrative Institutions, Regional and Local Authorities and other Subsidised Entities, for the current financial year.

REQUIREMENTS:

- have one (01) year of service in the rank of Chief Warrant Officer or Chief Petty Officer;
- be at most 42 years old on December 31 of the promotion year;
- be a vehicleer NCO;
- should have served for 15 years;
- be holder of a military diploma giving the right to scale 4 (BS2; CT2, BA2; OPJ);
- be highly rated.

CONSTITUTION OF FILE:

*** Required documents:**

- unstamped application for admission to the corps addressed to the Minister Delegate at the Presidency in charge of Defence;
- unstamped application to waive the rank of Senior Chief Warrant Officer addressed to the Minister Delegate at the Presidency in charge of Defence;
- proposal brief;
- highest civilian certificate;
- attestation of presentation of original of the diploma;
- text of appointment;
- score sheet;
- punishment record;
- note sheet;
- medical certificate signed by a Military Doctor;
- highest military certificate.

*** Reference documents:**

- text of appointment to the rank of Chief Warrant Officer or Chief Petty Officer;
- highest military certificate.

DEADLINE: Six (06) months

SIGNATORY OF THE INSTRUMENT: the President of the Republic

DELIVERY METHOD: Radio-press release/Notification/Collection

QUALITY SUPERVISOR: the Director of Human Resource

**PROCESSING: cf. processing chain: PROCEDURE No. 01/MINDEF/DRH/PPM/I
PROMOTION TO THE RANK OF OFFICER**

PROCEDURE No. 03/MINDEF/DRH/PPM/I
**ADVANCEMENT IN INCREMENTAL POSITION OF AN
OFFICER**

TITLE OF THE INSTRUMENT: Order on the advancement in incremental position of an officer

INITIATOR OF THE PROCEDURE: Administration/Applicant

INITIATING ENTITY: Advancement Bureau

REFERENCE INSTRUMENTS:

- Law No. 67/LF/9 of 12 June 1967 on the general organisation of Defence;
- Law No. 80/12 of 14 July 1980 to lay down general rules and regulations governing servicemen;
- Finance Law of the Republic of Cameroon for the current financial year;
- Decree No. 75/459 of 26 June 1975 to determine the remuneration scheme of civilian and military personnel of the Republic of Cameroon, as amended and supplemented by Decree No. 79/69 of 03 March 1979;
- Decree No. 75/791 of 18 December 1975 to lay down the salary index scale for senior civil servants in Cameroon;
- Decree No. 80/257 of 15 July 1980 to lay down general rules and regulations governing the remuneration schemes applicable to military personnel of the Armed Forces, together with all the amendments thereto;
- Decree No. 2001/177 of 25 July 2001 to organise the Ministry of Defence;
- Decree No. 2001/188 of 25 July 2001 to lay down special rules and regulations governing the corps of Active Officers of the Defence Forces;
- Decree No. 2018/190 of 02 March 2018 amending and supplementing certain provisions of Decree No. 2011/408 of 09 December 2011 to organise the Government;
- Decree No.....to lay down particular/special rules and regulations governing the corps concerned;
- Circular No./MINFI/ ofon the Instructions relating to the Implementation, Monitoring and Control of the Execution of the State Budget, Public Administrative Institutions, Regional and Local Authorities and other Subsidised Entities, for the current financial year.

REQUIREMENT: Have two (02) years of service in the last incremental position.

CONSTITUTION OF FILE:

* *Required documents:* N/A

* *Reference documents:*

- proposal brief;
- text of appointment to the last rank or incremental position;
- text of appointment;
- score sheet;
- punishment record;
- note sheet.

DEADLINE: Six (06) months









SIGNATORY OF THE INSTRUMENT: the Minister Delegate at the Presidency in charge of Defence









DELIVERY METHOD: Radio-press release/Notification/Collection

QUALITY SUPERVISOR: the Director of Human Resource

PROCESSING

MINISTRY OF DEFENCE	<p><i>PROCEDURE No.</i> 03/MINDEF/DRH/PPM/I <u>ADVANCEMENT IN INCREMENTAL POSITION OF AN OFFICER</u></p>	Procedure start date: 2023	
		Deadline	Procedure version: 1.0
		Page	
<i>Intervening parties</i>	<i>Stages</i>		<i>Handling rules</i>
	<p>Beginning</p>		<p>R1: Check file's compliance</p> <p>R2: Check the authenticity of information provided</p>
<p>Base Company</p>	<ul style="list-style-type: none"> - Receives the physical file; - Checks file's compliance; - Registers the file; - Initiates and signs the forwarding slip; - Forwards the file to the Department of Human Resource. 		<p>R3: Ensure that the applicant is eligible</p>
<p>Director of Human Resource</p>	<ul style="list-style-type: none"> - Receives the physical file; - Reviews; - Assigns the file. 		
<p>Head of Chancellery Service</p>	<ul style="list-style-type: none"> - Receives the physical file; - Reviews; - Assigns the file. 		
<p>Advancement Bureau Applicant</p>	<ul style="list-style-type: none"> - Receives the physical file; - Checks file's compliance; - Registers the file; - Initiates the draft order; - Initiates the forwarding slip and letter. 		
<p>Head of Chancellery Service</p>	<ul style="list-style-type: none"> - Receives the physical file; - Checks file's compliance; - Initials the draft order. 		

 <div style="border: 1px solid black; padding: 5px; width: fit-content;">Director of Human Resource</div>	<div style="border: 1px solid black; padding: 5px;"> <ul style="list-style-type: none"> - Receives the physical file; - Checks file's compliance; - Initials the draft order. </div>		
 <div style="border: 1px solid black; padding: 5px; width: fit-content;">Secretary General</div>	<div style="border: 1px solid black; padding: 5px;"> <ul style="list-style-type: none"> - Receives the physical file; - Checks file's compliance; - Initials the draft order; - Forwards to the Minister. </div>		
 <div style="border: 1px solid black; padding: 5px; width: fit-content;">Minister</div>	<div style="border: 1px solid black; padding: 5px;"> <ul style="list-style-type: none"> - Receives the physical file; - Reviews; - Signs the order. </div>		
 <div style="border: 1px solid black; padding: 5px; width: fit-content;">Head of Military Secretariat</div>	<div style="border: 1px solid black; padding: 5px;"> <ul style="list-style-type: none"> - Receives the forwarding slip and letter; - Reviews; - Breaks down the summons. </div>		
 <div style="border: 1px solid black; padding: 5px; width: fit-content;">Advancement Commission</div>	<div style="border: 1px solid black; padding: 5px;"> <ul style="list-style-type: none"> - Receives the physical file; - Reviews compliance; - Draws up a report. </div>		
 <div style="border: 1px solid black; padding: 5px; width: fit-content;">Director of Human Resource</div>	<div style="border: 1px solid black; padding: 5px;"> <ul style="list-style-type: none"> - Receives the report; - Reviews; - Assigns the file to the Head of Advancement Bureau. </div>		
 <div style="border: 1px solid black; padding: 5px; width: fit-content;">Head of Chancellery Service</div>	<div style="border: 1px solid black; padding: 5px;"> <ul style="list-style-type: none"> - Receives the physical file; - Assigns the file. </div>		
 <div style="border: 1px solid black; padding: 5px; width: fit-content;">Advancement Bureau</div>	<div style="border: 1px solid black; padding: 5px;"> <ul style="list-style-type: none"> - Receives the draft instrument and the physical file; - Reviews; - Initiates the draft instrument and the forwarding slip to the Presidency of the Republic. </div>		
 <div style="border: 1px solid black; padding: 5px; width: fit-content;">Head of Chancellery Service</div>	<div style="border: 1px solid black; padding: 5px;"> <ul style="list-style-type: none"> - Receives the physical file; - Initials the draft letter; - Forwards. </div>		

 <div style="border: 1px solid black; padding: 5px; width: fit-content;">Director of Human Resource</div>	<div style="border: 1px solid black; padding: 5px;"> <ul style="list-style-type: none"> - Receives the physical file; - Reviews; - Initials the draft forwarding letter to the Presidency of the Republic. </div>		
 <div style="border: 1px solid black; padding: 5px; width: fit-content;">Financial Controller</div>	<div style="border: 1px solid black; padding: 5px;"> <ul style="list-style-type: none"> - Receives the draft instrument; - Reviews; - Initials; - Forwards the file to the Department of Human Resource. </div>		
 <div style="border: 1px solid black; padding: 5px; width: fit-content;">Director of Human Resource</div>	<div style="border: 1px solid black; padding: 5px;"> <ul style="list-style-type: none"> - Receives the physical file; - Reviews; - Forwards the draft instrument and the forwarding letter to the Secretary General. </div>		
 <div style="border: 1px solid black; padding: 5px; width: fit-content;">Secretary General</div>	<div style="border: 1px solid black; padding: 5px;"> <ul style="list-style-type: none"> - Receives the forwarding slip and letter; - Initials the draft forwarding letter to the Minister. </div>		
 <div style="border: 1px solid black; padding: 5px; width: fit-content;">Minister</div>	<div style="border: 1px solid black; padding: 5px;"> <ul style="list-style-type: none"> - Receives the forwarding slip and letter; - Reviews; - Signs the forwarding letter. </div>		
 <div style="border: 1px solid black; padding: 5px; width: fit-content;">Military Secretariat</div>	<div style="border: 1px solid black; padding: 5px;"> <ul style="list-style-type: none"> - Receives the forwarding slip and letter; - Reviews; - Forwards the draft instrument and the forwarding letter to the Presidency of the Republic. </div>		
 <div style="border: 1px solid black; padding: 5px; width: fit-content;">Presidency of the Republic</div>	<div style="border: 1px solid black; padding: 5px;"> <ul style="list-style-type: none"> - Receives the physical file; - Checks the conformity and consistency of the instrument; - Affixes a stamp; - Returns the file to MINDEF. </div>		
 <div style="border: 1px solid black; padding: 5px; width: fit-content;">Military Secretariat</div>	<div style="border: 1px solid black; padding: 5px;"> <ul style="list-style-type: none"> - Receives the initialed draft instrument; - Reviews. </div>		

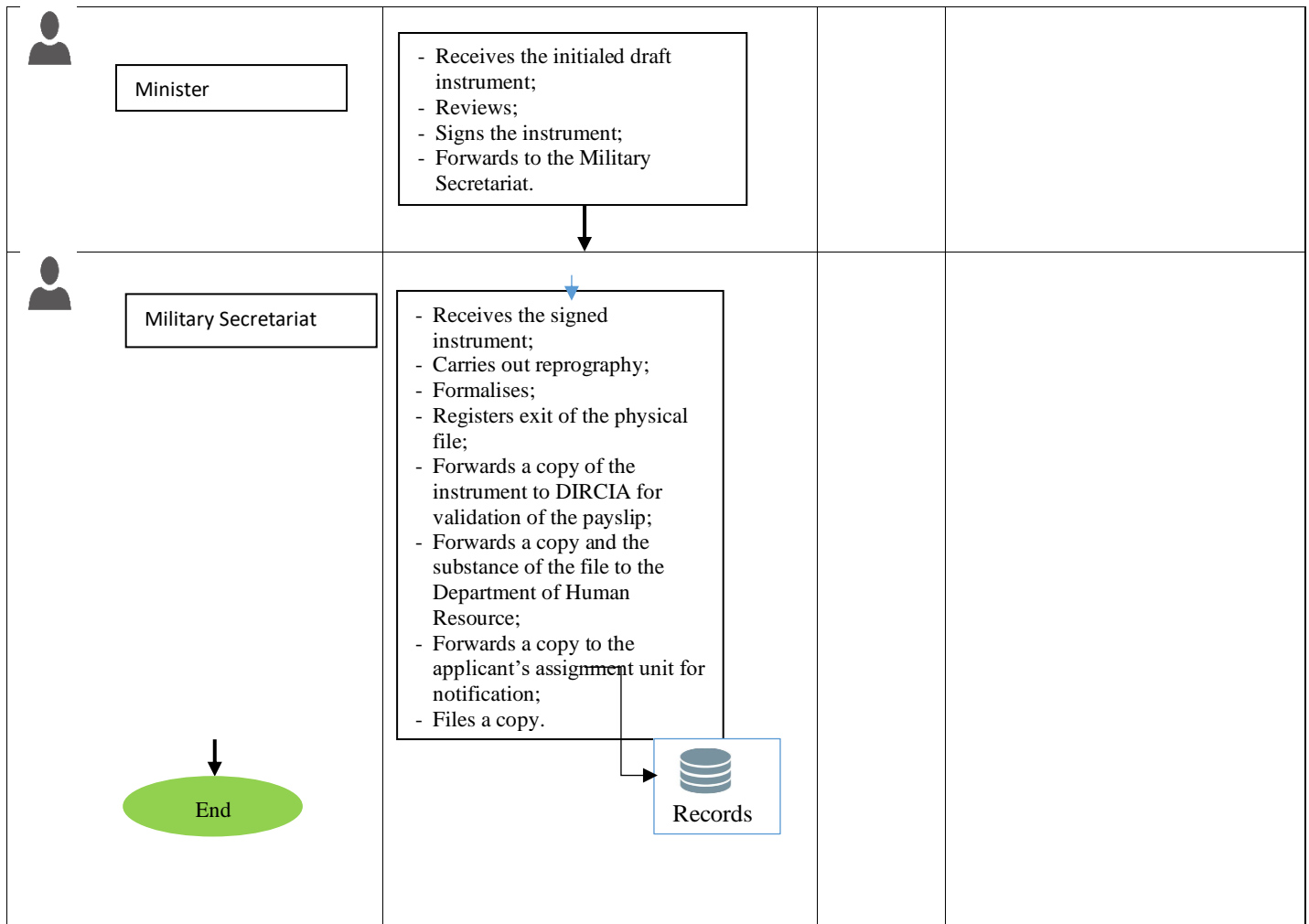

PROCEDURE No. 04/MINDEF/DRH/PPM/I
**PROMOTION OF A NON-COMMISSIONED SERVICE
MEMBER TO A HIGHER RANK**

TITLE OF THE INSTRUMENT: Decision promoting a non-commissioned service member to a higher rank

INITIATOR OF THE PROCEDURE: Administration/Applicant

INITIATING ENTITY/DE L'ACTE: Advancement Bureau

PLACE OF SUBMISSION OF FILE: Assignment unit

REFERENCE INSTRUMENTS:

- Law No. 67/LF/9 of 12 June 1967 on the general organisation of Defence;
- Law No. 80/12 of 14 July 1980 to lay down general rules and regulations governing servicemen;
- Finance Law of the Republic of Cameroon for the current financial year;
- Decree No. 75/459 of 26 June 1975 to determine the remuneration scheme of civilian and military personnel of the Republic of Cameroon, as amended and supplemented by Decree No. 79/69 of 03 March 1979;
- Decree No. 75/791 of 18 December 1975 to lay down the salary index scale for senior civil servants in Cameroon;
- Decree No. 80/257 of 15 July 1980 to lay down general rules and regulations governing the remuneration schemes applicable to military personnel of the Armed Forces, together with all the amendments thereto;
- Decree No. 2001/177 of 25 July 2001 to organise the Ministry of Defence;
- Decree No. 2001/188 of 25 July 2001 to lay down special rules and regulations governing the corps of Active Officers of the Defence Forces;
- Decree No. 2018/190 of 02 March 2018 amending and supplementing certain provisions of Decree No. 2011/408 of 09 December 2011 to organise the Government;
- Decree No.....to lay down particular/special rules and regulations governing the corps concerned;
- Circular No./MINFI/ ofon the Instructions relating to the Implementation, Monitoring and Control of the Execution of the State Budget, Public Administrative Institutions, Regional and Local Authorities and other Subsidised Entities, for the current financial year.

REQUIREMENTS:

- **For the rank of Senior Chief Warrant Officer or Fleet Chief Petty Officer:**
 - three (03) years of service in the rank of Chief Warrant Officer or Chief Petty Officer;
 - be holder of a BS2/CT2/BA2/OPJ;
- **For the rank of Chief Warrant Officer or Chief Petty Officer:**
 - be holder of a BS1/CT1/BA1/BE;
 - should have served for three years six months (3 years 6 months) by December 31 of the year of promotion;
 - be holder of a BS2/CT2/BA2/OPJ/BS;
 - should have served for three (03) years by December 31 of the year of promotion.
- **For the rank of Warrant Officer or First Master:**

- be holder of a CAT3;
- should have served for four (04) years by December 31 of the year of promotion;
- be holder of a BS1/CT1/BA1/BE/BS2/CT2/BA2/BS/OPJ;
- should have served for three (03) years by December 31 of the year of promotion.

- **For the rank of Gendarmerie Staff Sergeant, Army Staff Sergeant or Petty Officer Class 2:**
 - be holder of a CAT2;
 - should have served for four (04) years by December 31 of the year of promotion;
 - be holder of a CAT3;
 - should have served for three years six months (3 years 6 months) by December 31 of the year of promotion;
 - be holder of a BS1/CT1/BA1/BE/BS2/CT2/BA2/BS/OPJ;
 - should have served for three (03) years by December 31 of the year of promotion.
- **For the rank of Gendarmerie Sergeant, Army Sergeant or Petty Officer Class 3:**
 - be holder of a CAT2;
 - should have served for one (01) year by December 31 of the year of promotion.
- **For the rank of Gendarme Major:**
 - be holder of a CAT1;
 - have three (03) years of service in the rank of Gendarme by December 31 of the year of promotion;
 - Automatic at 8 years of Gendarme rank.
- **For the rank of Lance Corporal or Leading Rating First Class:**
 - be holder of a CAT2;
 - should have served for six (06) months in the rank of Corporal;
- **For the rank of Corporal or Leading Rating Second Class:**
 - be holder of a CAT1;
 - have three (03) years of service.

CONSTITUTION OF FILE:

*** Required documents:**

- proposal brief;
- text of appointment to the current or previous rank;
- text of appointment;
- score sheet;
- punishment record;
- note sheet.

*** Reference documents:**

- text of appointment to the previous rank;
- service note laying down the conditions for advancement.

DEADLINE: Six (06) months

SIGNATORY OF THE INSTRUMENT: the Minister Delegate at the Presidency in charge of Defence

DELIVERY METHOD: Radio-press release/Notification/Collection

QUALITY SUPERVISOR: the Director of Human Resource

PROCESSING: cf. processing chain: *PROCEDURE No. 03/MINDEF/DRH/PPM/I*
ADVANCEMENT IN INCREMENTAL POSITION OF AN OFFICER

PROCEDURE No. 05/MINDEF/DRH/PPM/I
PROMOTION TO THE POSITIONS OF PRIVATE FIRST CLASS
AND SEAMAN SECOND CLASS

TITLE OF THE INSTRUMENT: Decision on promotion to the positions of private first class and seaman second class

INITIATOR OF THE PROCEDURE: Administration

INITIATING ENTITY: Service note

REFERENCE INSTRUMENTS:

- Law No. 67/LF/9 of 12 June 1967 on the general organisation of Defence;
- Law No. 80/12 of 14 July 1980 to lay down general rules and regulations governing servicemen;
- Finance Law of the Republic of Cameroon for the current financial year;
- Decree No. 75/459 of 26 June 1975 to determine the remuneration scheme of civilian and military personnel of the Republic of Cameroon, as amended and supplemented by Decree No. 79/69 of 03 March 1979;
- Decree No. 75/791 of 18 December 1975 to lay down the salary index scale for senior civil servants in Cameroon;
- Decree No. 80/257 of 15 July 1980 to lay down general rules and regulations governing the remuneration schemes applicable to military personnel of the Armed Forces, together with all the amendments thereto;
- Decree No. 2001/177 of 25 July 2001 to organise the Ministry of Defence;
- Decree No. 2001/188 of 25 July 2001 to lay down special rules and regulations governing the corps of Active Officers of the Defence Forces;
- Decree 2001/219 du 06 aout 2001 portant statut particulier des military personnel non-officier des forces de défense ;
- Decree No. 2018/190 of 02 March 2018 amending and supplementing certain provisions of Decree No. 2011/408 of 09 December 2011 to organise the Government;
- Decree No.....to lay down particular/special rules and regulations governing the corps concerned;
- Circular No./MINFI/ ofon the Instructions relating to the Implementation, Monitoring and Control of the Execution of the State Budget, Public Administrative Institutions, Regional and Local Authorities and other Subsidised Entities, for the current financial year.

REQUIREMENT: Have three (03) years of service.

CONSTITUTION OF FILE:

* *Required documents:* N/A





* *Reference documents:* N/A

DEADLINE: Six (06) months

SIGNATORY OF THE INSTRUMENT: the Chief of Staff

DELIVERY METHOD: Notification/Collection

QUALITY SUPERVISOR: the Director of Human Resource
PROCESSING

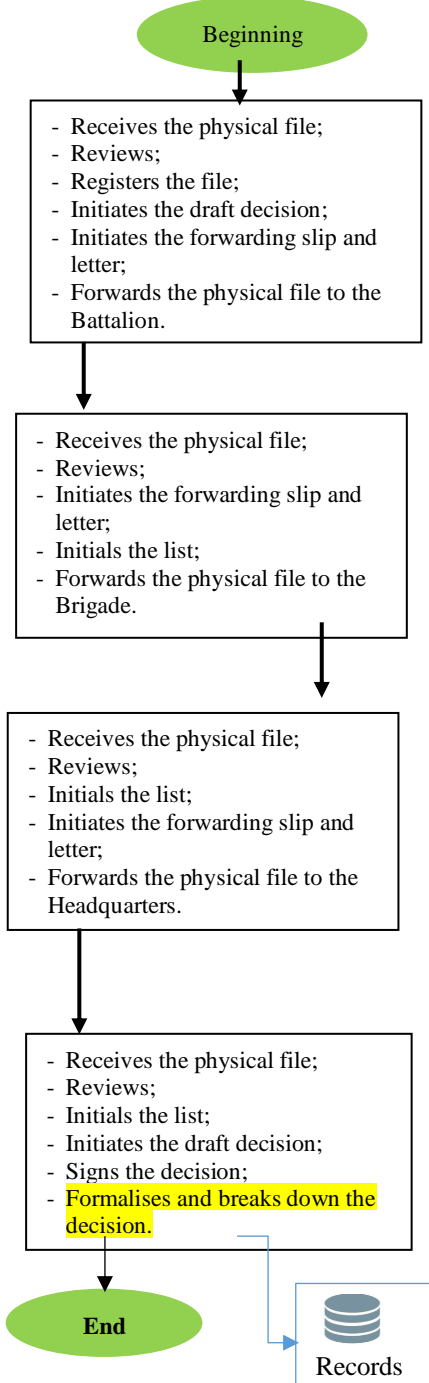
MINISTRY OF DEFENCE	PROCEDURE No. 05/MINDEF/EM/PPM/I <u>PROMOTION TO THE POSITIONS OF PRIVATE FIRST CLASS AND SEAMAN SECOND CLASS</u>	Procedure start date: 2023	
		Deadline	Procedure version: 1.0
			Page
<i>Intervening parties</i>	<i>Stages</i>		<i>Handling rules</i>
 Base Company  Battalion  Brigade  Headquarters	 <pre> graph TD Start([Beginning]) --> S1[Base Company] S1 --> S2[Battalion] S2 --> S3[Brigade] S3 --> S4[Headquarters] S4 --> End([End]) S4 --> Records[Records] </pre> <p>The flowchart details the following stages:</p> <ul style="list-style-type: none"> Base Company: <ul style="list-style-type: none"> - Receives the physical file; - Reviews; - Registers the file; - Initiates the draft decision; - Initiates the forwarding slip and letter; - Forwards the physical file to the Battalion. Battalion: <ul style="list-style-type: none"> - Receives the physical file; - Reviews; - Initiates the forwarding slip and letter; - Initials the list; - Forwards the physical file to the Brigade. Brigade: <ul style="list-style-type: none"> - Receives the physical file; - Reviews; - Initials the list; - Initiates the forwarding slip and letter; - Forwards the physical file to the Headquarters. Headquarters: <ul style="list-style-type: none"> - Receives the physical file; - Reviews; - Initials the list; - Initiates the draft decision; - Signs the decision; - Formalises and breaks down the decision. 	<p>R1: Check file's compliance</p> <p>R2: Ensure the authenticity of the information provided and the availability of places</p>	

VOLUME 3
DISCIPLINE OF MILITARY PERSONNEL

DISCIPLINARY PROCEDURES

DEPARTMENT OF HUMAN RESOURCE

OFFICERS

1. STRIKING AN OFFICER OFF THE ROLL OF ADVANCEMENT IN RANK/INCREMENTAL POSITION
2. PLACING AN OFFICER ON INACTIVE STATUS BY WITHDRAWAL OF POST
3. DISCHARGING AN OFFICER ON DISCIPLINARY GROUNDS
4. COMPULSORY RETIREMENT OF AN OFFICER
5. DISMISSAL OF AN OFFICER
6. DEMOTION OF AN OFFICER
7. AUTOMATIC DISCIPLINARY TRANSFER

NON-COMMISSIONED SERVICE PERSONNEL

8. REPRIMANDING A NON-COMMISSIONED SERVICE MEMBER
9. WARNING A NON-COMMISSIONED SERVICE MEMBER
10. DISCIPLINARY DUTY FOR A NON-COMMISSIONED SERVICE MEMBER
11. REPRIMANDING A NON-COMMISSIONED SERVICE MEMBER
12. REGULAR/MANDATORY DAYS OFF OF A NON-COMMISSIONED SERVICE MEMBER
13. IMPRISONMENT OF A NON-COMMISSIONED SERVICE MEMBER
14. AUTOMATIC DISCIPLINARY TRANSFER OF A NON-COMMISSIONED SERVICE MEMBER
15. SUSPENSION OR WITHDRAWAL OF POST OF A NON-COMMISSIONED SERVICE MEMBER
16. DEMOTION OF A RANK AND FILE FROM PRIVATE FIRST CLASS TO PRIVATE SECOND CLASS
17. DEMOTION/CANCELLATION/TERMINATION OF ENLISTMENT OR RE-ENLISTMENT CONTRACT OF A NON-COMMISSIONED SERVICE MEMBER
18. COMPULSORY RETIREMENT OF A NON-COMMISSIONED SERVICE MEMBER

SECRETARIAT OF STATE FOR DEFENCE IN CHARGE

OF THE NATIONAL GENDARMERIE

19. DEDUCTION OR SUSPENSION OF SALARY THROUGH DISCIPLINARY ACTION

SUPERIOR

DEPARTMENT OF HUMAN RESOURCE

OFFICERS

PROCEDURE No. 01/MINDEF/DRH/PDDO/I
**STRIKING AN OFFICER OFF THE ROLL OF ADVANCEMENT
IN RANK/INCREMENTAL POSITION**

TITLE OF THE INSTRUMENT:

- Order striking an officer off the roll of advancement in rank;
- Order striking an officer off the roll of advancement in incremental position.

INITIATOR OF THE PROCEDURE: Administration

INITIATING ENTITY: Disciplinary Bureau

PLACE OF SUBMISSION OF FILE: Assignment unit

REFERENCE INSTRUMENTS:

- Law No. 67/LF/9 of 12 June 1967 on the general organisation of Defence;
- Law No. 80/12 of 14 July 1980 to lay down general rules and regulations governing servicemen;
- Decree No. 78/530/PR of 21 December 1978 on disciplinary power;
- Decree No. 2001/177 of 25 July 2001 to organise the Ministry of Defence;
- Decree No. 2001/188 of 25 July 2001 to lay down special rules and regulations governing the corps of Active Officers of the Defence Forces;
- Decree No. 2007/199 of 07 July 2007 to lay down Rules of General Discipline in the Defence Forces;
- Decree No. 2011/410 of 09 December 2011 to organise the Government;
- Decree No. 2018/190 of 02 March 2018 amending and supplementing certain provisions of Decree No. 2011/408 of 09 December 2011 to organise the Government.

REQUIREMENTS:

- be an officer;
- should have committed an offence that warrants dismissal.

CONSTITUTION OF FILE:

* *Required documents:* N/A

* *Reference documents:*

- report of the Disciplinary Council;
- disciplinary record.

DEADLINE: Four (04) months

SIGNATORY OF THE INSTRUMENT: the President of the Republic

DELIVERY METHOD: Notification/Collection

QUALITY SUPERVISOR: the Director of Human Resource

PROCESSING

DEPARTMENT OF HUMAN RESOURCE	PROCEDURE No. 01/MINDEF/DRH/PDDO/I <u>STRIKING AN OFFICER OFF THE ROLL OF ADVANCEMENT IN RANK/INCREMENTAL POSITION</u>	Procedure start date: 2023	
		Procedure version:	
		Deadline	Page
<i>Intervening parties</i>	<i>Stages</i>		<i>Handling rules</i>
<p>Official who took note of the offence</p>	<p>Beginning</p> <ul style="list-style-type: none"> - Submits a detailed report; - Initiates a forwarding slip/letter; - Registers exit of the physical file; - Forwards the file to the Department of Human Resource through the chain of command. 		<p>R1: Check file's compliance</p> <p>R2: Ensure procedure consistency</p>
<p>Staff/SEDCGN</p>	<ul style="list-style-type: none"> - Receives the file; - Registers the file; - Initiates the applicant's reduced file; - Initiates a proposal for the composition of the Disciplinary Council; - Forwards the physical file. 		
<p>Director of Human Resource</p>	<ul style="list-style-type: none"> - Receives the physical file; - Reviews the physical file; - Assigns the physical file. 		
<p>Head of Chancellery Service</p>	<ul style="list-style-type: none"> - Receives the physical file; - Reviews the physical file; - Assigns the physical file. 		
<p>Head of Disciplinary Bureau</p>	<ul style="list-style-type: none"> - Receives the physical file; - Reviews the physical file; - Initiates the plan to convene the Disciplinary Council; - Forwards the physical file. 		
<p>Head of Chancellery Service</p>	<ul style="list-style-type: none"> - Receives the physical file; - Initiates the plan to convene the Disciplinary Council; - Forwards the physical file. 		
<p>Director of Human Resource</p>	<ul style="list-style-type: none"> - Receives the physical file; - Issues a notice; - Initiates the plan to convene the Disciplinary Council; - Keeps the disciplinary file; - Forwards the reduced file and the convocation plan. 		

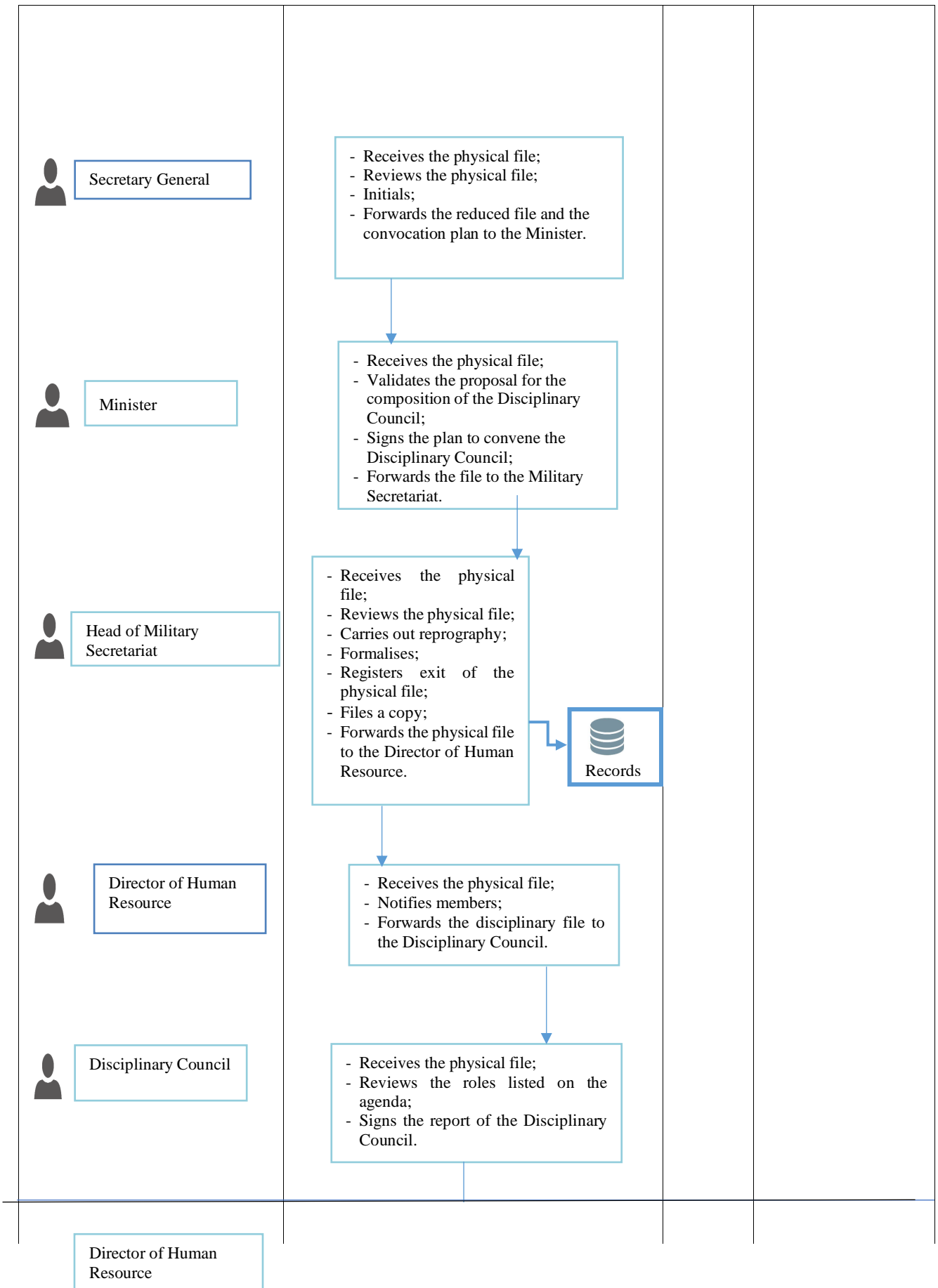

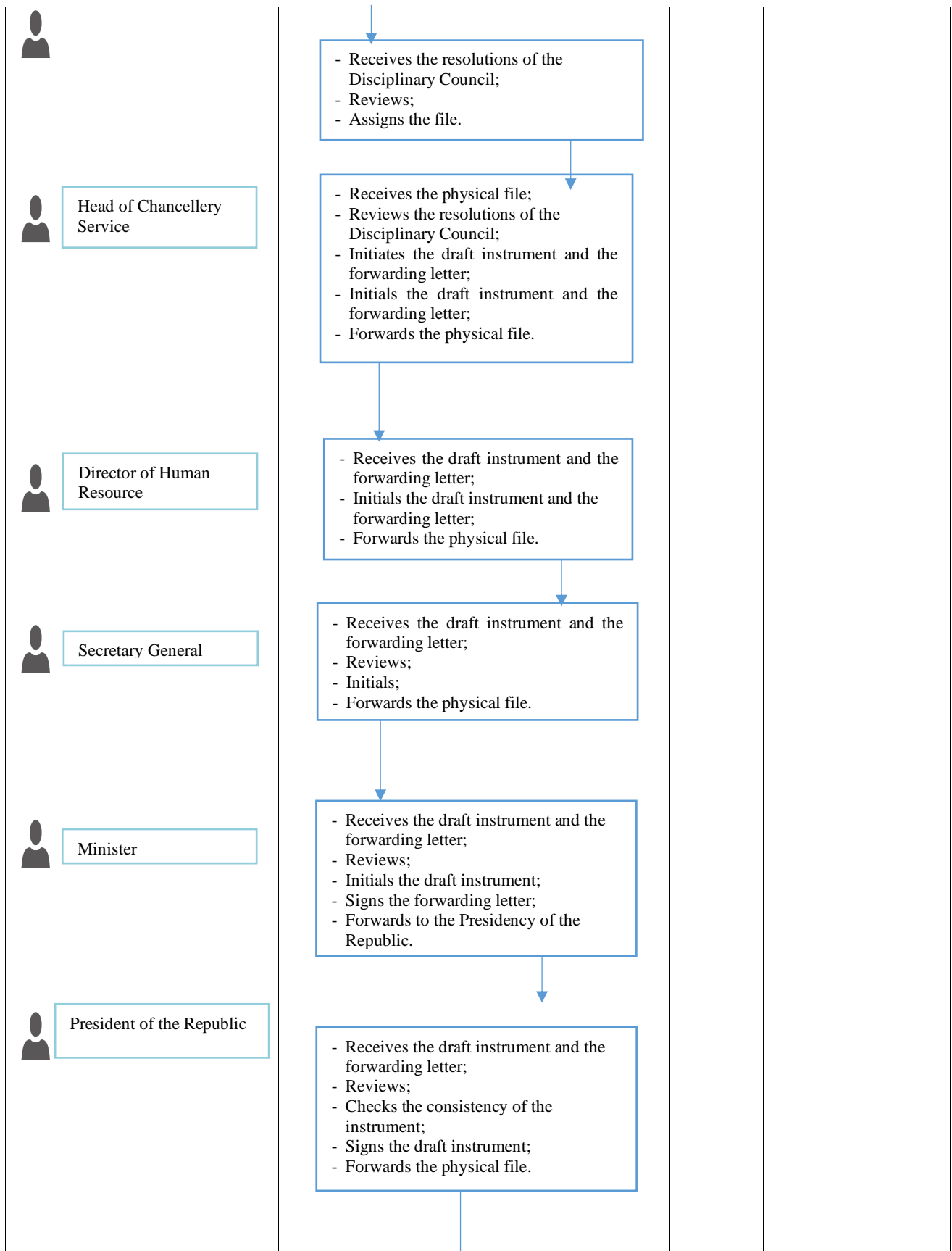

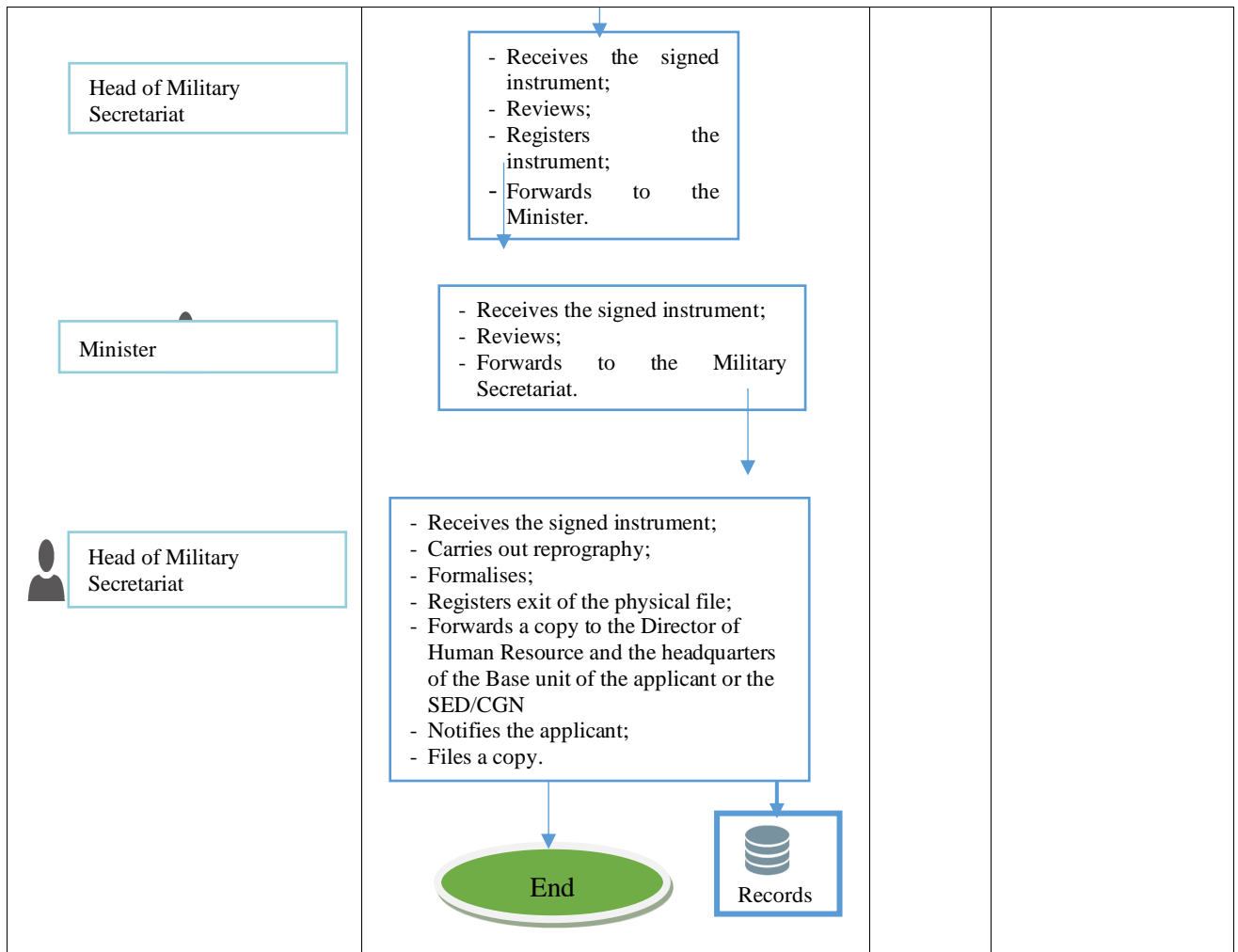

**PROCEDURE No. 02/MINDEF/DRH/PDDO/I
PLACING AN OFFICER ON INACTIVE STATUS BY
WITHDRAWAL OF POST**

TITLE OF THE INSTRUMENT: Decree placing an officer on inactive status by withdrawal of post

INITIATOR OF THE PROCEDURE: Administration

INITIATING ENTITY: Disciplinary Bureau

PLACE OF SUBMISSION OF FILE: Assignment unit

REFERENCE INSTRUMENTS:

- Law No. 67/LF/9 of 12 June 1967 on the general organisation of Defence;
- Law No. 80/12 of 14 July 1980 to lay down general rules and regulations governing servicemen;
- Decree No. 78/530/PR of 21 December 1978 on disciplinary power;
- Decree No. 2001/177 of 25 July 2001 to organise the Ministry of Defence;
- Decree No. 2001/188 of 25 July 2001 to lay down special rules and regulations governing the corps of Active Officers of the Defence Forces;
- Decree No. 2007/199 of 07 July 2007 to lay down Rules of General Discipline in the Defence Forces;
- Decree No. 2011/410 of 09 December 2011 to organise the Government;
- Decree No. 2018/190 of 02 March 2018 amending and supplementing certain provisions of Decree No. 2011/408 of 09 December 2011 to organise the Government;
- Decree No. 2018/191 of 02 March 2018 to reshuffle the Government.

REQUIREMENTS:

- be an officer;
- should have committed an offence that warrants being put on inactive status.

CONSTITUTION OF FILE:

* *Required documents:* N/A

* *Reference documents:*

- report of the Disciplinary Council;
- disciplinary record.

DEADLINE: Four (04) months

SIGNATORY OF THE INSTRUMENT: the President of the Republic

DELIVERY METHOD: Notification

QUALITY SUPERVISOR: the Director of Human Resource

**PROCESSING: cf. processing chain: PROCEDURE No. 01/MINDEF/DRH/PDDO/I
STRIKING AN OFFICER OFF THE ROLL OF ADVANCEMENT IN
RANK/INCREMENTAL POSITION**

**PROCEDURE No. 03/MINDEF/DRH/PDDO/I
DISCHARGING AN OFFICER ON DISCIPLINARY GROUNDS**

TITLE OF THE INSTRUMENT: Decree discharging an officer on disciplinary grounds

INITIATOR OF THE PROCEDURE: Administration

INITIATING ENTITY: Disciplinary Bureau

REFERENCE INSTRUMENTS:

- Law No. 67/LF/9 of 12 June 1967 on the general organisation of Defence;
- Law No. 80/12 of 14 July 1980 to lay down general rules and regulations governing servicemen;
- Decree No. 78/530/PR of 21 December 1978 on disciplinary power;
- Decree No. 2001/177 of 25 July 2001 to organise the Ministry of Defence;
- Decree No. 2001/188 of 25 July 2001 to lay down special rules and regulations governing the corps of Active Officers of the Defence Forces;
- Decree No. 2007/199 of 07 July 2007 to lay down Rules of General Discipline in the Defence Forces;
- Decree No. 2011/410 of 09 December 2011 to organise the Government;
- Decree No. 2018/190 of 02 March 2018 amending and supplementing certain provisions of Decree No. 2011/408 of 09 December 2011 to organise the Government;
- Decree No. 2018/191 of 02 March 2018 to reshuffle the Government.

REQUIREMENTS:

- be an officer;
- should have committed an offence that warrants being discharged.

CONSTITUTION OF FILE:

* **Required documents:** N/A

* **Reference documents:**

- report of the Disciplinary Council;
- disciplinary record.

DEADLINE: Four (04) months

SIGNATORY OF THE INSTRUMENT: the President of the Republic

DELIVERY METHOD: Notification/Collection

QUALITY SUPERVISOR: the Director of Human Resource

PROCESSING: cf. processing chain: **PROCEDURE No. 01/MINDEF/DRH/PDDO/I
STRIKING AN OFFICER OFF THE ROLL OF ADVANCEMENT IN
RANK/INCREMENTAL POSITION**

PROCEDURE No. 04/MINDEF/DRH/PDDO/I
COMPULSORY RETIREMENT OF AN OFFICER

TITLE OF THE INSTRUMENT: Decree placing an officer on compulsory retirement

INITIATOR OF THE PROCEDURE: Administration

INITIATING ENTITY: Disciplinary Bureau

REFERENCE INSTRUMENTS:

- Law No. 67/LF/9 of 12 June 1967 on the general organisation of Defence;
- Law No. 80/12 of 14 July 1980 to lay down general rules and regulations governing servicemen;
- Decree No. 78/530/PR of 21 December 1978 on disciplinary power;
- Decree No. 2001/177 of 25 July 2001 to organise the Ministry of Defence;
- Decree No. 2001/188 of 25 July 2001 to lay down special rules and regulations governing the corps of Active Officers of the Defence Forces;
- Decree No. 2007/199 of 07 July 2007 to lay down Rules of General Discipline in the Defence Forces;
- Decree No. 2011/410 of 09 December 2011 to organise the Government;
- Decree No. 2018/190 of 02 March 2018 amending and supplementing certain provisions of Decree No. 2011/408 of 09 December 2011 to organise the Government;
- Decree No. 2018/191 of 02 March 2018 to reshuffle the Government.

REQUIREMENTS:

- be an officer;
- should have committed an offence that warrants being placed on compulsory retirement as an officer.

CONSTITUTION OF FILE:

* *Required documents:* N/A

* *Reference documents:*

- report of the Disciplinary Council;
- disciplinary record.

DEADLINE: Four (04) months

SIGNATORY OF THE INSTRUMENT: the President of the Republic

DELIVERY METHOD: Notification

QUALITY SUPERVISOR: the Director of Human Resource

PROCESSING: cf. processing chain: **PROCEDURE No. 01/MINDEF/DRH/PDDO/I
STRIKING AN OFFICER OFF THE ROLL OF ADVANCEMENT IN
RANK/INCREMENTAL POSITION**

**PROCEDURE No. 05/MINDEF/DRH/PDDO/I
DISMISSAL OF AN OFFICER**

TITLE OF THE INSTRUMENT: Decree to dismiss an officer

INITIATOR OF THE PROCEDURE: Administration

INITIATING ENTITY: Disciplinary Bureau

REFERENCE INSTRUMENTS:

- Law No. 67/LF/9 of 12 June 1967 on the general organisation of Defence;
- Law No. 80/12 of 14 July 1980 to lay down general rules and regulations governing servicemen;
- Decree No. 78/530/PR of 21 December 1978 on disciplinary power;
- Decree No. 2001/177 of 25 July 2001 to organise the Ministry of Defence;
- Decree No. 2001/188 of 25 July 2001 to lay down special rules and regulations governing the corps of Active Officers of the Defence Forces;
- Decree No. 2007/199 of 07 July 2007 to lay down Rules of General Discipline in the Defence Forces;
- Decree No. 2011/410 of 09 December 2011 to organise the Government;
- Decree No. 2018/190 of 02 March 2018 amending and supplementing certain provisions of Decree No. 2011/408 of 09 December 2011 to organise the Government;
- Decree No. 2018/191 of 02 March 2018 to reshuffle the Government.

REQUIREMENTS:

- be an officer;
- should have committed an offence that warrants being dismissed.

CONSTITUTION OF FILE:

* **Required documents:** N/A

* **Reference documents:**

- report of the Disciplinary Council;
- disciplinary record.

DEADLINE: Four (04) months

SIGNATORY OF THE INSTRUMENT: the President of the Republic

DELIVERY METHOD: Notification/Collection

QUALITY SUPERVISOR: the Director of Human Resource

**PROCESSING: cf. processing chain: PROCEDURE No. 01/MINDEF/DRH/PDDO/I
STRIKING AN OFFICER OFF THE ROLL OF ADVANCEMENT IN
RANK/INCREMENTAL POSITION**

**PROCEDURE No. 06/MINDEF/DRH/PDDO/I
DEMOTION OF AN OFFICER**

TITLE OF THE INSTRUMENT: Decree to demote an officer

INITIATOR OF THE PROCEDURE: Administration

INITIATING ENTITY: Disciplinary Bureau

REFERENCE INSTRUMENTS:

- Law No. 67/LF/9 of 12 June 1967 on the general organisation of Defence;
- Law No. 80/12 of 14 July 1980 to lay down general rules and regulations governing servicemen;
- Decree No. 78/530/PR of 21 December 1978 on disciplinary power;
- Decree No. 2001/177 of 25 July 2001 to organise the Ministry of Defence;
- Decree No. 2001/188 of 25 July 2001 to lay down special rules and regulations governing the corps of Active Officers of the Defence Forces;
- Decree No. 2007/199 of 07 July 2007 to lay down Rules of General Discipline in the Defence Forces;
- Decree No. 2011/410 of 09 December 2011 to organise the Government;
- Decree No. 2018/190 of 02 March 2018 amending and supplementing certain provisions of Decree No. 2011/408 of 09 December 2011 to organise the Government;
- Decree No. 2018/191 of 02 March 2018 to reshuffle the Government.

REQUIREMENTS:

- be an officer;
- should have committed a serious offence that warrants being dismissed.

CONSTITUTION OF FILE:

* *Required documents:* N/A

* *Reference documents:*

- report of the Disciplinary Council;
- disciplinary record.

DEADLINE: Four (04) months

SIGNATORY OF THE INSTRUMENT: the President of the Republic

DELIVERY METHOD: Notification/Collection

QUALITY SUPERVISOR: the Director of Human Resource

**PROCESSING: cf. processing chain: PROCEDURE No. 01/MINDEF/DRH/PDDO/I
STRIKING AN OFFICER OFF THE ROLL OF ADVANCEMENT IN
RANK/INCREMENTAL POSITION**

**PROCEDURE No. 07/MINDEF/DRH/PDDO/I
AUTOMATIC DISCIPLINARY TRANSFER**

TITLE OF THE INSTRUMENT: Message on the automatic disciplinary transfer of a military personnel

INITIATOR OF THE PROCEDURE: Administration

INITIATING ENTITY: Disciplinary Bureau

REFERENCE INSTRUMENTS:

- Law No. 67/LF/9 of 12 June 1967 on the general organisation of Defence;
- Law No. 80/12 of 14 July 1980 to lay down general rules and regulations governing servicemen;
- Decree No. 78/530/PR of 21 December 1978 on disciplinary power;
- Decree No. 2001/177 of 25 July 2001 to organise the Ministry of Defence;
- Decree No. 2001/188 of 25 July 2001 to lay down special rules and regulations governing the corps of Active Officers of the Defence Forces;
- Decree No. 2007/199 of 07 July 2007 to lay down Rules of General Discipline in the Defence Forces;
- Decree No. 2011/410 of 09 December 2011 to organise the Government;
- Decree No. 2018/190 of 02 March 2018 amending and supplementing certain provisions of Decree No. 2011/408 of 09 December 2011 to organise the Government;
- Decree No. 2018/191 of 02 March 2018 to reshuffle the Government.

REQUIREMENTS:

- be an officer;
- should have committed a disciplinary offence.

CONSTITUTION OF FILE:

* *Required documents:* N/A

* *Reference documents:*









- report of the Disciplinary Council;
- disciplinary record.

DEADLINE: Four (04) months

SIGNATORY OF THE INSTRUMENT: Minister Delegate at the Presidency in charge of Defence

DELIVERY METHOD: Notification/Collection

QUALITY SUPERVISOR: the Director of Human Resource

PROCESSING			
DEPARTMENT OF HUMAN RESOURCE	PROCEDURE No. 07/ /MINDEF/DRH/PDDO/I <u>AUTOMATIC DISCIPLINARY TRANSFER</u>	Procedure start date: 2023	
		Procedure version:	
		Deadline	Page
<i>Intervening parties</i>	<i>Stages</i>		<i>Handling rules</i>
			
 <div style="border: 1px solid black; padding: 5px; width: fit-content;">Official who took note of the offence</div>	<div style="border: 1px solid black; padding: 10px;"> <ul style="list-style-type: none"> - Submits a detailed report; - Initiates the forwarding slip/letter; - Registers exit of the physical file; - Forwards the file to the Staff/SEDCGN. </div>		R1: Check file's compliance R2: Ensure procedure consistency
 <div style="border: 1px solid black; padding: 5px; width: fit-content;">Staff/SEDCGN</div>	<div style="border: 1px solid black; padding: 10px;"> <ul style="list-style-type: none"> - Receives the file; - Registers the file; - Initiates the reduced file of the applicant; - Initiates a proposal for the composition of the Disciplinary Council; - Forwards the physical file. </div>		
 <div style="border: 1px solid black; padding: 5px; width: fit-content;">Director of Human Resource</div>	<div style="border: 1px solid black; padding: 10px;"> <ul style="list-style-type: none"> - Receives the physical file; - Reviews the physical file; - Assigns the physical file. </div>		
 <div style="border: 1px solid black; padding: 5px; width: fit-content;">Head of Chancellery Service</div>	<div style="border: 1px solid black; padding: 10px;"> <ul style="list-style-type: none"> - Receives the physical file; - Reviews the physical file; - Assigns the physical file. </div>		
 <div style="border: 1px solid black; padding: 5px; width: fit-content;">Head of Disciplinary Bureau</div>	<div style="border: 1px solid black; padding: 10px;"> <ul style="list-style-type: none"> - Receives the physical file; - Reviews the physical file; - Initiates the plan to convene the Disciplinary Council; - Forwards the physical file. </div>		
 <div style="border: 1px solid black; padding: 5px; width: fit-content;">Head of Chancellery Service</div>	<div style="border: 1px solid black; padding: 10px;"> <ul style="list-style-type: none"> - Receives the physical file; - Initiates the plan to convene the Disciplinary Council; - Forwards the physical file. </div>		
 <div style="border: 1px solid black; padding: 5px; width: fit-content;">Director of Human Resource</div>	<div style="border: 1px solid black; padding: 10px;"> <ul style="list-style-type: none"> - Receives the physical file; - Issues a notice; - Initials the draft plan to convene the Disciplinary Council; - Keeps the disciplinary file; - Forwards the reduced file and the convocation plan. </div>		

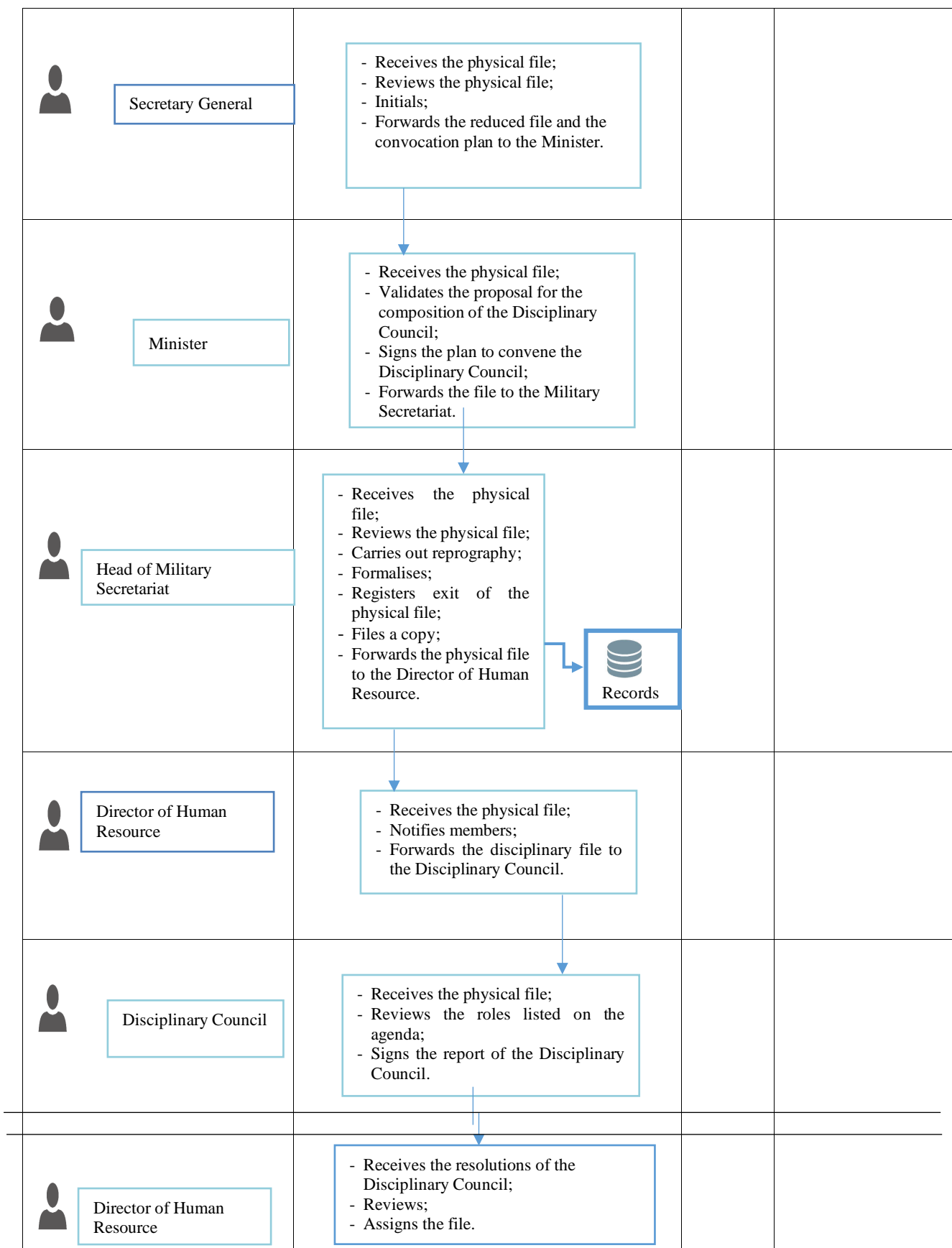

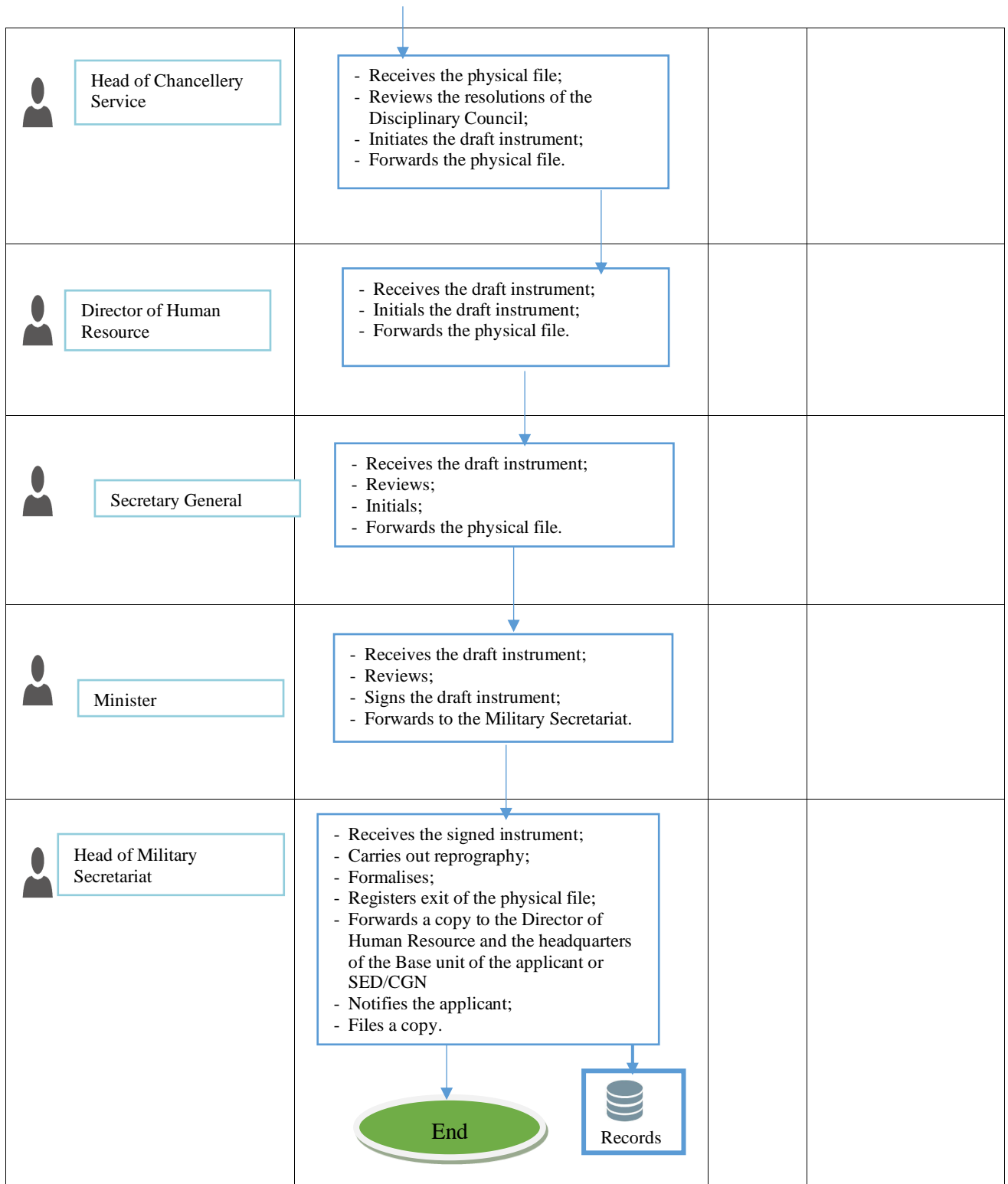

NON-COMMISSIONED SERVICE PERSONNEL

PROCEDURE No. 08/MINDEF/DRH/PDPMNO/1
**REPRIMANDING A NON-COMMISSIONED SERVICE
MEMBER**

TITLE OF THE INSTRUMENT: Order reprimanding a non-commissioned service member

INITIATOR OF THE PROCEDURE: Administration

INITIATING ENTITY: Disciplinary Bureau

REFERENCE INSTRUMENTS:

- Law No. 67/LF/9 of 12 June 1967 on the general organisation of Defence;
- Law No. 80/12 of 14 July 1980 to lay down general rules and regulations governing servicemen;
- Decree No. 78/530/PR of 21 December 1978 on disciplinary power;
- Decree No. 2001/177 of 25 July 2001 to organise the Ministry of Defence;
- Decree No. 2001/219 of 06 August 2001 to lay down special rules and regulations governing non-commissioned officers of the Defence Forces;
- Decree No. 2011/410 of 09 December 2011 to organise the Government;
- Decree No. 2007/199 of 07 July 2007 to lay down Rules of General Discipline in the Defence Forces;
- Decree No. 2018/190 of 02 March 2018 amending and supplementing certain provisions of Decree No. 2011/408 of 09 December 2011 to organise the Government;
- Decree No. 2018/191 of 02 March 2018 to reshuffle the Government.

REQUIREMENTS:

- be a non-commissioned service member;
- should have committed a serious offence that warrants being reprimanded.

CONSTITUTION OF FILE:

* *Required documents:* N/A

* *Reference documents:*

- report of the Disciplinary Council;
- disciplinary record.

DEADLINE: Four (04) months

SIGNATORY OF THE INSTRUMENT: the Minister Delegate at the Presidency in charge of Defence







DELIVERY METHOD: Notification

QUALITY SUPERVISOR: the Director of Human Resource

PROCESSING

DEPARTMENT OF HUMAN RESOURCE	PROCEDURE No. 08/MINDEF/DRH/PDPN/I <u>REPRIMANDING A NON- COMMISSIONED SERVICE MEMBER</u>	Procedure start date: 2023
		Procedure version:

		Deadline	Page
<i>Intervening parties</i>	<i>Stages</i>		<i>Handling rules</i>
<div style="border: 1px solid black; padding: 2px; width: fit-content;">Official who took note of the offence</div>	<div style="border: 1px solid black; padding: 5px;"> <ul style="list-style-type: none"> - Submits a detailed report; - Initiates the forwarding slip/letter; - Registers exit of the physical file; - Forwards the file to the Staff/SEDCGN. </div>		R1: Check file's compliance R2: Ensure procedure consistency
<div style="border: 1px solid black; padding: 2px; width: fit-content;">Staff/SEDCGN</div>	<div style="border: 1px solid black; padding: 5px;"> <ul style="list-style-type: none"> - Receives the file; - Registers the file; - Initiates the reduced file of the applicant; - Initiates a proposal for the composition of the Disciplinary Council; - Forwards the physical file. </div>		
<div style="border: 1px solid black; padding: 2px; width: fit-content;">Director of Human Resource</div>	<div style="border: 1px solid black; padding: 5px;"> <ul style="list-style-type: none"> - Receives the physical file; - Reviews the physical file; - Assigns the physical file. </div>		
<div style="border: 1px solid black; padding: 2px; width: fit-content;">Head of Chancellery Service</div>	<div style="border: 1px solid black; padding: 5px;"> <ul style="list-style-type: none"> - Receives the physical file; - Reviews the physical file; - Assigns the physical file. </div>		
<div style="border: 1px solid black; padding: 2px; width: fit-content;">Head of Disciplinary Bureau</div>	<div style="border: 1px solid black; padding: 5px;"> <ul style="list-style-type: none"> - Receives the physical file; - Reviews the physical file; - Initiates the plan to convene the Disciplinary Council; - Forwards the physical file. </div>		
<div style="border: 1px solid black; padding: 2px; width: fit-content;">Head of Chancellery Service</div>	<div style="border: 1px solid black; padding: 5px;"> <ul style="list-style-type: none"> - Receives the physical file; - Initiates the plan to convene the Disciplinary Council; - Forwards the physical file. </div>		
<div style="border: 1px solid black; padding: 2px; width: fit-content;">Director of Human Resource</div>	<div style="border: 1px solid black; padding: 5px;"> <ul style="list-style-type: none"> - Receives the physical file; - Issues a notice; - Initials the draft plan to convene the Disciplinary Council; - Keeps the disciplinary file; - Forwards the reduced file and the convocation plan. </div>		

 <p>Secretary General</p>	<p>↓</p> <ul style="list-style-type: none"> - Receives the physical file; - Reviews the physical file; - Initials; - Forwards the reduced file and the convocation plan to the Minister. <p>↓</p>		
 <p>Minister</p>	<ul style="list-style-type: none"> - Receives the physical file; - Validates the proposal for the composition of the Disciplinary Council; - Signs the plan to convene the Disciplinary Council; - Forwards the file to the Military Secretariat. <p>↓</p>		
 <p>Head of Military Secretariat</p>	<ul style="list-style-type: none"> - Receives the physical file; - Reviews the physical file; - Carries out reprography; - Formalises; - Registers exit of the physical file; - Files a copy; - Forwards the physical file to the Director of Human Resource. <p>↓</p> 		
 <p>Director of Human Resource</p>	<ul style="list-style-type: none"> - Receives the physical file; - Notifies members; - Forwards the disciplinary file to the Disciplinary Council. <p>↓</p>		
 <p>Disciplinary Council</p>	<ul style="list-style-type: none"> - Receives the physical file; - Reviews the roles listed on the agenda; - Signs the report of the Disciplinary Council. <p>↓</p>		
 <p>Director of Human Resource</p>	<ul style="list-style-type: none"> - Receives the resolutions of the Disciplinary Council; - Reviews; - Assigns the file. 		

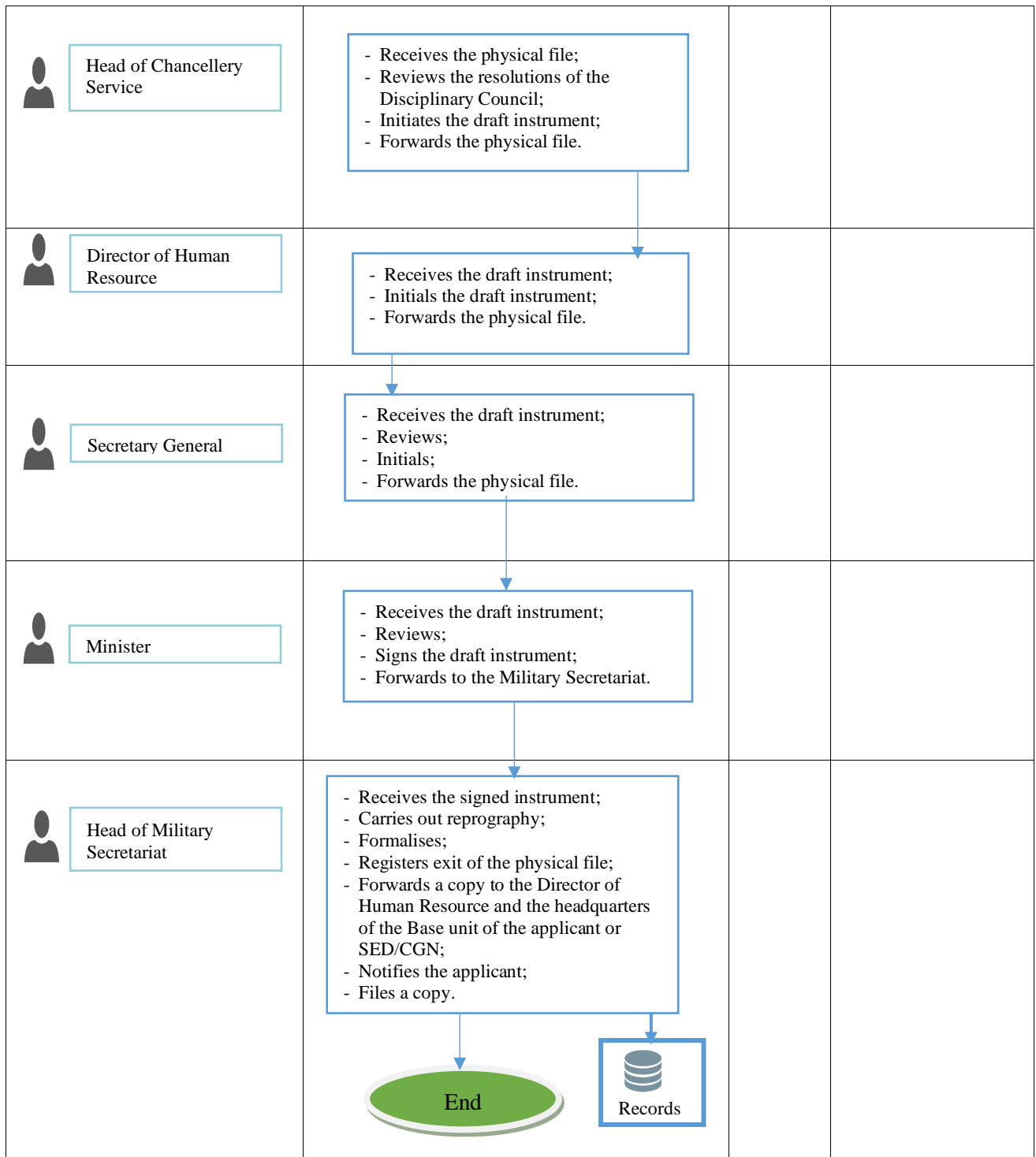

**PROCEDURE No. 09/MINDEF/DRH/PDPMNO/I
WARNING A NON-COMMISSIONED SERVICE MEMBER**

TITLE OF THE INSTRUMENT: Order warning a non-commissioned service member
INITIATOR OF THE PROCEDURE: Administration
INITIATING ENTITY: Disciplinary Bureau

REFERENCE INSTRUMENTS:

- Law No. 67/LF/9 of 12 June 1967 on the general organisation of Defence;
- Law No. 80/12 of 14 July 1980 to lay down general rules and regulations governing servicemen;
- Decree No. 78/530/PR of 21 December 1978 on disciplinary power;
- Decree No. 2001/177 of 25 July 2001 to organise the Ministry of Defence;
- Decree No. 2001/219 of 06 August 2001 to lay down special rules and regulations governing non-commissioned officers of the Defence Forces;
- Decree No. 2011/410 of 09 December 2011 to organise the Government;
- Decree No. 2007/199 of 07 July 2007 to lay down Rules of General Discipline in the Defence Forces;
- Decree No. 2018/190 of 02 March 2018 amending and supplementing certain provisions of Decree No. 2011/408 of 09 December 2011 to organise the Government;
- Decree No. 2018/191 of 02 March 2018 to reshuffle the Government.

REQUIREMENTS:

- be a non-commissioned service member;
- should have committed a serious offence that warrants a warning.

CONSTITUTION OF FILE:

* **Required documents:** N/A

* **Reference documents:**

- report of the Disciplinary Council;
- disciplinary record.

DEADLINE: Four (04) months

SIGNATORY OF THE INSTRUMENT: the Minister Delegate at the Presidency in charge of Defence

DELIVERY METHOD: Notification

QUALITY SUPERVISOR: the Director of Human Resource

PROCESSING: cf. processing chain: **PROCEDURE No. 08/MINDEF/DRH/PDPN/I REPRIMANDING A NON-COMMISSIONED SERVICE MEMBER**

**PROCEDURE No. 10/MINDEF/DRH/PDPMNO/I
DISCIPLINARY DUTY FOR A NON-COMMISSIONED SERVICE
MEMBER**

TITLE OF THE INSTRUMENT: Order assigning a disciplinary duty to a non-commissioned service member

INITIATOR OF THE PROCEDURE: Administration

INITIATING ENTITY: Disciplinary Bureau

REFERENCE INSTRUMENTS:

- Law No. 67/LF/9 of 12 June 1967 on the general organisation of Defence;
- Law No. 80/12 of 14 July 1980 to lay down general rules and regulations governing servicemen;
- Decree No. 78/530/PR of 21 December 1978 on disciplinary power;
- Decree No. 2001/177 of 25 July 2001 to organise the Ministry of Defence;
- Decree No. 2001/219 of 06 August 2001 to lay down special rules and regulations governing non-commissioned officers of the Defence Forces;
- Decree No. 2011/410 of 09 December 2011 to organise the Government;
- Decree No. 2007/199 of 07 July 2007 to lay down Rules of General Discipline in the Defence Forces;
- Decree No. 2018/190 of 02 March 2018 amending and supplementing certain provisions of Decree No. 2011/408 of 09 December 2011 to organise the Government;
- Decree No. 2018/191 of 02 March 2018 to reshuffle the Government.

REQUIREMENTS:

- be a non-commissioned service member;
- should have committed a serious offence that warrants a disciplinary duty.

CONSTITUTION OF FILE:

* *Required documents:* N/A

* *Reference documents:*

- report of the Disciplinary Council;
- disciplinary record.

DEADLINE: Four (04) months

SIGNATORY OF THE INSTRUMENT: the Minister Delegate at the Presidency in charge of Defence

DELIVERY METHOD: Notification

QUALITY SUPERVISOR: the Director of Human Resource

**PROCESSING: cf. processing chain: PROCEDURE No. 08/MINDEF/DRH/PDPN/I
REPRIMANDING A NON-COMMISSIONED SERVICE MEMBER**

PROCEDURE No. 11/MINDEF/DRH/PDPMNO/I
**REPRIMANDING A NON-COMMISSIONED SERVICE
MEMBER**

TITLE OF THE INSTRUMENT: Order reprimanding a non-commissioned service member

INITIATOR OF THE PROCEDURE: Administration

INITIATING ENTITY: Disciplinary Bureau

REFERENCE INSTRUMENTS:

- Law No. 67/LF/9 of 12 June 1967 on the general organisation of Defence;

- Law No. 80/12 of 14 July 1980 to lay down general rules and regulations governing servicemen;
- Decree No. 78/530/PR of 21 December 1978 on disciplinary power;
- Decree No. 2001/177 of 25 July 2001 to organise the Ministry of Defence;
- Decree No. 2001/219 of 06 August 2001 to lay down special rules and regulations governing non-commissioned officers of the Defence Forces;
- Decree No. 2011/410 of 09 December 2011 to organise the Government;
- Decree No. 2007/199 of 07 July 2007 to lay down Rules of General Discipline in the Defence Forces ;
- Decree No. 2018/190 of 02 March 2018 amending and supplementing certain provisions of Decree No. 2011/408 of 09 December 2011 to organise the Government;
- Decree No. 2018/191 of 02 March 2018 to reshuffle the Government.

REQUIREMENTS:

- be a non-commissioned service member;
- should have committed a serious offence that warrants being reprimanded.

CONSTITUTION OF FILE:

* *Required documents:* N/A

* *Reference documents:*

- report of the Disciplinary Council;
- disciplinary record.

DEADLINE: Four (04) months

SIGNATORY OF THE INSTRUMENT: the Minister Delegate at the Presidency in charge of Defence

DELIVERY METHOD: Notification

QUALITY SUPERVISOR: the Director of Human Resource

PROCESSING: cf. processing chain: **PROCEDURE No. 08/MINDEF/DRH/PDPN/I REPRIMANDING A NON-COMMISSIONED SERVICE MEMBER**

**PROCEDURE No. 12/MINDEF/DRH/PDPMNO/I
REGULAR/MANDATORY DAYS OFF OF A NON-
COMMISSIONED SERVICE MEMBER**

TITLE OF THE INSTRUMENT: Order on regular/mandatory days off of a non-commissioned service member

INITIATOR OF THE PROCEDURE: Administration

INITIATING ENTITY: Disciplinary Bureau

REFERENCE INSTRUMENTS:

- Law No. 67/LF/9 of 12 June 1967 on the general organisation of Defence;
- Law No. 80/12 of 14 July 1980 to lay down general rules and regulations governing servicemen;
- Decree No. 78/530/PR of 21 December 1978 on disciplinary power;
- Decree No. 2001/177 of 25 July 2001 to organise the Ministry of Defence;
- Decree No. 2001/219 of 06 August 2001 to lay down special rules and regulations governing non-commissioned officers of the Defence Forces;
- Decree No. 2011/410 of 09 December 2011 to organise the Government;
- Decree No. 2007/199 of 07 July 2007 to lay down Rules of General Discipline in the Defence Forces;
- Decree No. 2018/190 of 02 March 2018 amending and supplementing certain provisions of Decree No. 2011/408 of 09 December 2011 to organise the Government;
- Decree No. 2018/191 of 02 March 2018 to reshuffle the Government.

REQUIREMENTS:

- be a non-commissioned service member;
- should have committed a serious offence that warrants a temporary suspension.

CONSTITUTION OF FILE:

* *Required documents:* N/A

* *Reference documents:*

- report of the Disciplinary Council;
- disciplinary record.

DEADLINE: Four (04) months

SIGNATORY OF THE INSTRUMENT: the Minister Delegate at the Presidency in charge of Defence

DELIVERY METHOD: Notification/Collection

QUALITY SUPERVISOR: the Director of Human Resource

PROCESSING: cf. processing chain: **PROCEDURE No. 08/MINDEF/DRH/PDPN/I**
REPRIMANDING A NON-COMMISSIONED SERVICE MEMBER

PROCEDURE No. 13/MINDEF/DRH/PDPMNO/I
IMPRISONMENT OF A NON-COMMISSIONED SERVICE MEMBER

TITLE OF THE INSTRUMENT: Decision on the imprisonment of a non-commissioned service member

INITIATOR OF THE PROCEDURE: Administration

INITIATING ENTITY: Disciplinary Bureau

REFERENCE INSTRUMENTS:

- Law No. 67/LF/9 of 12 June 1967 on the general organisation of Defence;
- Law No. 80/12 of 14 July 1980 to lay down general rules and regulations governing servicemen;
- Decree No. 78/530/PR of 21 December 1978 on disciplinary power;
- Decree No. 2001/177 of 25 July 2001 to organise the Ministry of Defence;
- Decree No. 2001/219 of 06 August 2001 to lay down special rules and regulations governing non-commissioned officers of the Defence Forces;
- Decree No. 2011/410 of 09 December 2011 to organise the Government;
- Decree No. 2007/199 of 07 July 2007 to lay down Rules of General Discipline in the Defence Forces;
- Decree No. 2018/190 of 02 March 2018 amending and supplementing certain provisions of Decree No. 2011/408 of 09 December 2011 to organise the Government;
- Decree No. 2018/191 of 02 March 2018 to reshuffle the Government.

REQUIREMENTS:

- be a non-commissioned service member;
- should have committed a serious offence that warrants imprisonment.

CONSTITUTION OF FILE:

* *Required documents:* N/A

* *Reference documents:*

- report of the Disciplinary Council;
- disciplinary record.

DEADLINE: Four (04) months

SIGNATORY OF THE INSTRUMENT: the Minister Delegate at the Presidency in charge of Defence

DELIVERY METHOD: Notification/Collection

QUALITY SUPERVISOR: the Director of Human Resource

PROCESSING: cf. processing chain: **PROCEDURE No. 08/MINDEF/DRH/PDPN/I REPRIMANDING A NON-COMMISSIONED SERVICE MEMBER**

PROCEDURE No. 14/MINDEF/DRH/PDPMNO/I
AUTOMATIC DISCIPLINARY TRANSFER OF A NON-COMMISSIONED SERVICE MEMBER

TITLE OF THE INSTRUMENT: Decision on the automatic disciplinary transfer of a non-commissioned service member

INITIATOR OF THE PROCEDURE: Administration

INITIATING ENTITY: Disciplinary Bureau

REFERENCE INSTRUMENTS:

- Law No. 67/LF/9 of 12 June 1967 on the general organisation of Defence;
- Law No. 80/12 of 14 July 1980 to lay down general rules and regulations governing servicemen;
- Decree No. 78/530/PR of 21 December 1978 on disciplinary power;
- Decree No. 2001/177 of 25 July 2001 to organise the Ministry of Defence;
- Decree No. 2001/219 of 06 August 2001 to lay down special rules and regulations governing non-commissioned officers of the Defence Forces;
- Decree No. 2011/410 of 09 December 2011 to organise the Government;
- Decree No. 2007/199 of 07 July 2007 to lay down Rules of General Discipline in the Defence Forces;
- Decree No. 2018/190 of 02 March 2018 amending and supplementing certain provisions of Decree No. 2011/408 of 09 December 2011 to organise the Government;
- Decree No. 2018/191 of 02 March 2018 to reshuffle the Government.

REQUIREMENTS:

- be a non-commissioned service member;
- should have committed a disciplinary offence.

CONSTITUTION OF FILE:

* *Required documents:* N/A

* *Reference documents:*

- report of the Disciplinary Council;
- disciplinary record.

DEADLINE: Four (04) months

SIGNATORY OF THE INSTRUMENT: the Minister Delegate at the Presidency in charge of Defence

DELIVERY METHOD: Notification/Collection

QUALITY SUPERVISOR: the Director of Human Resource

PROCESSING: cf. processing chain: **PROCEDURE No. 08/MINDEF/DRH/PDPN/I REPRIMANDING A NON-COMMISSIONED SERVICE MEMBER**

PROCEDURE No. 15/MINDEF/DRH/PDPMNO/I
SUSPENSION OR WITHDRAWAL OF POST OF A NON-COMMISSIONED SERVICE MEMBER

TITLE OF THE INSTRUMENT: Decision on the suspension or withdrawal of post of a non-commissioned service member

INITIATOR OF THE PROCEDURE: Administration

INITIATING ENTITY: Disciplinary Bureau

REFERENCE INSTRUMENTS:

- Law No. 67/LF/9 of 12 June 1967 on the general organisation of Defence;
- Law No. 80/12 of 14 July 1980 to lay down general rules and regulations governing servicemen;
- Decree No. 78/530/PR of 21 December 1978 on disciplinary power;
- Decree No. 2001/177 of 25 July 2001 to organise the Ministry of Defence;
- Decree No. 2001/219 of 06 August 2001 to lay down special rules and regulations governing non-commissioned officers of the Defence Forces;
- Decree No. 2011/410 of 09 December 2011 to organise the Government;
- Decree No. 2007/199 of 07 July 2007 to lay down Rules of General Discipline in the Defence Forces;
- Decree No. 2018/190 of 02 March 2018 amending and supplementing certain provisions of Decree No. 2011/408 of 09 December 2011 to organise the Government;
- Decree No. 2018/191 of 02 March 2018 to reshuffle the Government.

REQUIREMENTS:

- be a non-commissioned service member;
- should have committed a serious offence that warrants a suspension or withdrawal of post.

CONSTITUTION OF FILE:

* *Required documents:* N/A

* *Reference documents:*

- report of the Disciplinary Council;
- disciplinary record.

DEADLINE: Four (04) months

SIGNATORY OF THE INSTRUMENT: the Minister Delegate at the Presidency in charge of Defence

DELIVERY METHOD: Notification/Collection

QUALITY SUPERVISOR: the Director of Human Resource

PROCESSING: cf. processing chain: **PROCEDURE No. 08/MINDEF/DRH/PDPN/I REPRIMANDING A NON-COMMISSIONED SERVICE MEMBER**

PROCEDURE No. 16/MINDEF/DRH/PDPMNO/I
DEMOTION OF A RANK AND FILE FROM PRIVATE FIRST CLASS TO PRIVATE SECOND CLASS

TITLE OF THE INSTRUMENT: Decision on the demotion of a rank and file from private first class to private second class

INITIATOR OF THE PROCEDURE: Administration

INITIATING ENTITY: Disciplinary Bureau

REFERENCE INSTRUMENTS:

- Law No. 67/LF/9 of 12 June 1967 on the general organisation of Defence;
- Law No. 80/12 of 14 July 1980 to lay down general rules and regulations governing servicemen;
- Decree No. 78/530/PR of 21 December 1978 on disciplinary power;
- Decree No. 2001/177 of 25 July 2001 to organise the Ministry of Defence;
- Decree No. 2001/219 of 06 August 2001 to lay down special rules and regulations governing non-commissioned officers of the Defence Forces;
- Decree No. 2011/410 of 09 December 2011 to organise the Government;
- Decree No. 2007/199 of 07 July 2007 to lay down Rules of General Discipline in the Defence Forces;
- Decree No. 2018/190 of 02 March 2018 amending and supplementing certain provisions of Decree No. 2011/408 of 09 December 2011 to organise the Government;
- Decree No. 2018/191 of 02 March 2018 to reshuffle the Government.

REQUIREMENTS:

- be a non-commissioned service member;
- should have committed a serious offence that warrants the demotion of a rank and file from private first class to private second class.

CONSTITUTION OF FILE:

* *Required documents:* N/A

* *Reference documents:*

- report of the Disciplinary Council;
- disciplinary record.

DEADLINE: Four (04) months

SIGNATORY OF THE INSTRUMENT: the Minister Delegate at the Presidency in charge of Defence

DELIVERY METHOD: Notification/Collection

QUALITY SUPERVISOR: the Director of Human Resource

PROCESSING: cf. processing chain: **PROCEDURE No. 08/MINDEF/DRH/PDPN/I
REPRIMANDING A NON-COMMISSIONED SERVICE MEMBER**

PROCEDURE No. 17/MINDEF/DRH/PDPMNO/I
**DEMOTION/CANCELLATION/TERMINATION OF
ENLISTMENT OR RE-ENLISTMENT CONTRACT OF A NON-
COMMISSIONED SERVICE MEMBER**

TITLE OF THE INSTRUMENT: Decision on the demotion/cancellation/termination of enlistment or re-enlistment contract of a non-commissioned service member

INITIATOR OF THE PROCEDURE: Administration

INITIATING ENTITY: Disciplinary Bureau

REFERENCE INSTRUMENTS:

- Law No. 67/LF/9 of 12 June 1967 on the general organisation of Defence;

- Law No. 80/12 of 14 July 1980 to lay down general rules and regulations governing servicemen;
- Decree No. 78/530/PR of 21 December 1978 on disciplinary power;
- Decree No. 2001/177 of 25 July 2001 to organise the Ministry of Defence;
- Decree No. 2001/219 of 06 August 2001 to lay down special rules and regulations governing non-commissioned officers of the Defence Forces;
- Decree No. 2011/410 of 09 December 2011 to organise the Government;
- Decree No. 2007/199 of 07 July 2007 to lay down Rules of General Discipline in the Defence Forces;
- Decree No. 2018/190 of 02 March 2018 amending and supplementing certain provisions of Decree No. 2011/408 of 09 December 2011 to organise the Government;
- Decree No. 2018/191 of 02 March 2018 to reshuffle the Government.

REQUIREMENTS:

- be a service member under contract;
- be a non-commissioned service member;
- should have committed a serious offence that warrants demotion, cancellation or termination of contract.

CONSTITUTION OF FILE:

* *Required documents:* N/A

* *Reference documents:*

- report of the Disciplinary Council;
- disciplinary record.

DEADLINE: Four (04) months

SIGNATORY OF THE INSTRUMENT: the Minister Delegate at the Presidency in charge of Defence

DELIVERY METHOD: Notification/Collection

QUALITY SUPERVISOR: the Director of Human Resource

PROCESSING: cf. processing chain: **PROCEDURE No. 08/MINDEF/DRH/PDPN/I
REPRIMANDING A NON-COMMISSIONED SERVICE MEMBER**

PROCEDURE No. 18/MINDEF/DRH/PDPMNO/I
**COMPULSORY RETIREMENT OF A NON-COMMISSIONED
SERVICE MEMBER**

TITLE OF THE INSTRUMENT: Order placing a non-commissioned service member on compulsory retirement

INITIATOR OF THE PROCEDURE: Administration

INITIATING ENTITY: Disciplinary Bureau

REFERENCE INSTRUMENTS:

- Law No. 67/LF/9 of 12 June 1967 on the general organisation of Defence;
- Law No. 80/12 of 14 July 1980 to lay down general rules and regulations governing servicemen;
- Decree No. 78/530/PR of 21 December 1978 on disciplinary power;
- Decree No. 2001/177 of 25 July 2001 to organise the Ministry of Defence;
- Decree No. 2001/219 of 06 August 2001 to lay down special rules and regulations governing non-commissioned officers of the Defence Forces;
- Decree No. 2011/410 of 09 December 2011 to organise the Government;
- Decree No. 2007/199 of 07 July 2007 to lay down Rules of General Discipline in the Defence Forces;
- Decree No. 2018/190 of 02 March 2018 amending and supplementing certain provisions of Decree No. 2011/408 of 09 December 2011 to organise the Government;
- Decree No. 2018/191 of 02 March 2018 to reshuffle the Government.

REQUIREMENTS:

- be an officer;
- should have committed a serious offence that warrants the compulsory retirement of a non-commissioned service member.

CONSTITUTION OF FILE:

* *Required documents:* N/A

* *Reference documents:*

- report of the Disciplinary Council;
- disciplinary record.

DEADLINE: Four (04) months

SIGNATORY OF THE INSTRUMENT: the Minister Delegate at the Presidency in charge of Defence

DELIVERY METHOD: Notification

QUALITY SUPERVISOR: the Director of Human Resource

PROCESSING: cf. processing chain: **PROCEDURE No. 08/MINDEF/DRH/PDPN/I
REPRIMANDING A NON-COMMISSIONED SERVICE MEMBER**

**SECRETARIAT OF STATE FOR DEFENCE IN
CHARGE OF THE NATIONAL GENDARMERIE**

PROCEDURE No. 19/MINDEF/SGN/PDPNO/I
**DEDUCTION/SUSPENSION OF SALARY THROUGH
DISCIPLINARY ACTION**

TITLE OF THE INSTRUMENT: Message on salary deduction/suspension

INITIATOR OF THE PROCEDURE: Administration

INITIATING ENTITY: Non-Commissioned Personnel Bureau

REFERENCE INSTRUMENTS:

- Law No. 67/LF/9 of 12 June 1967 on the general organisation of Defence;

- Law No. 80/12 of 14 July 1980 to lay down general rules and regulations governing servicemen;
- Decree No. 78/530/PR of 21 December 1978 on disciplinary power;
- Decree No. 2001/177 of 25 July 2001 to organise the Ministry of Defence;
- Decree No. 2001/219 of 06 August 2001 to lay down special rules and regulations governing non-commissioned officers of the Defence Forces;
- Decree No. 2011/410 of 09 December 2011 to organise the Government;
- Decree No. 2007/199 of 07 July 2007 to lay down Rules of General Discipline in the Defence Forces;
- Decree No. 2018/190 of 02 March 2018 amending and supplementing certain provisions of Decree No. 2011/408 of 09 December 2011 to organise the Government;
- Decree No. 2018/191 of 02 March 2018 to reshuffle the Government.

REQUIREMENTS:

- be a non-commissioned member of the Gendarmerie;
- be under punishment.

CONSTITUTION OF FILE:

* **Required documents:** N/A

* **Reference documents:**

- punishment record;
- deserters file.

DEADLINE: Four (04) months

SIGNATORY OF THE INSTRUMENT: the SED/CGN

DELIVERY METHOD: Notification

QUALITY SUPERVISOR: the Director of Human Resource

PROCESSING

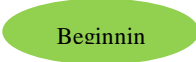
MINISTRY OF DEFENCE	PROCEDURE No. 19/MINDEF/SGN/PDPN/I DEDUCTION/SUSPENSION OF SALARY THROUGH DISCIPLINARY ACTION	Procedure start date: 2023	
		Deadline	Procedure version:
		Page	Handling rules
<i>Intervening parties</i>	<i>Stages</i>		
			

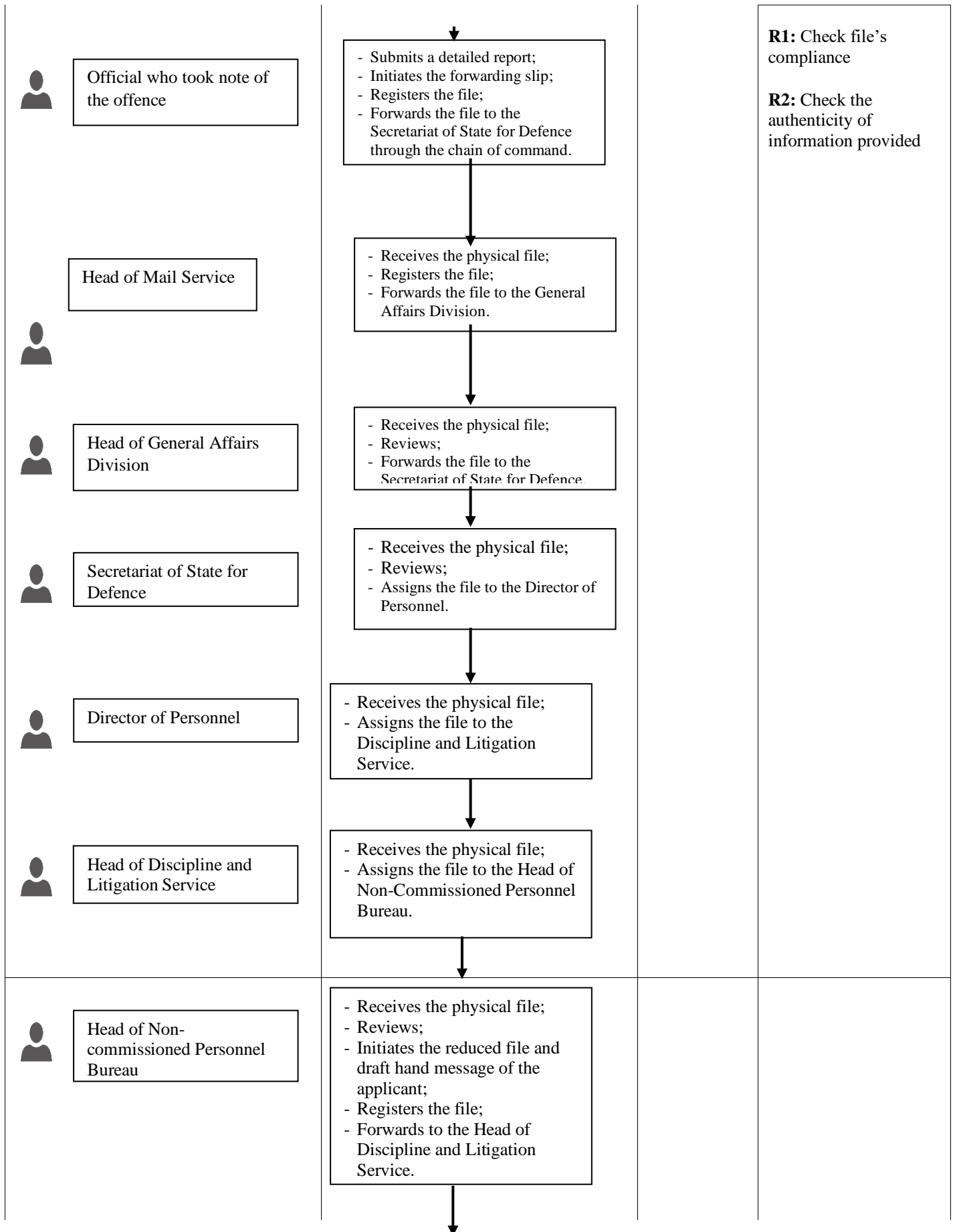

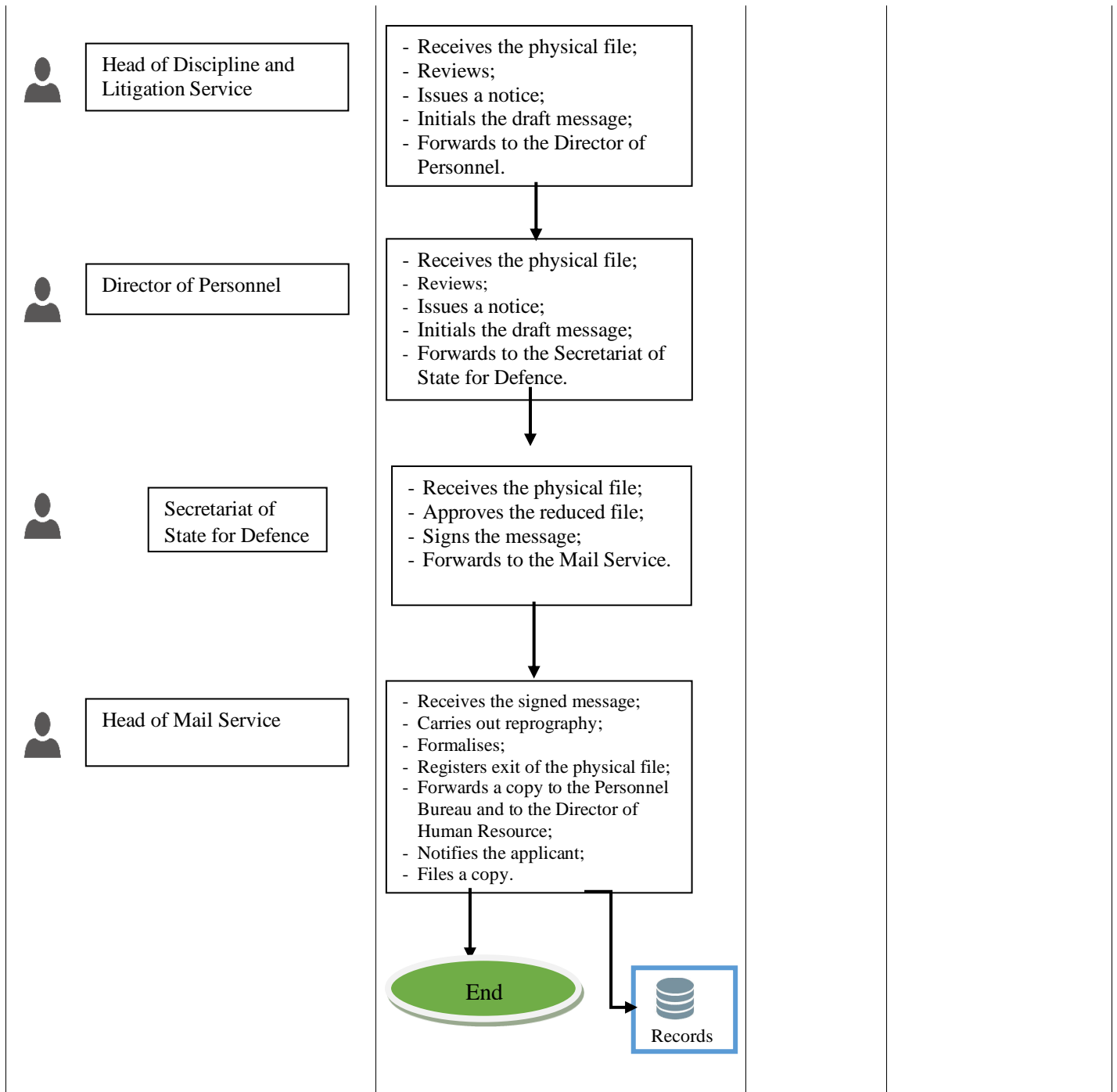

SUPERIOR

NB. The sanctions imposed by the superior are set out in the Rules of General Discipline (RDG) and are listed in the table below. They are more of operating procedures because of, among other things, their immediacy and the reduced number of interventions and formalities.

A. AGAINST OFFICERS

AUTHORITIES	SANCTIONS				
	Disciplinary measures			Administrative	
	Warning	Reprimand	Warning (b)	Minors	Majors
SED-CEMA- CGA-IGA- Chief of Army Staff – COLOG- DCPMAIR- Central Directors -COMRMIA- COMRSM - CORGEN	X	X	X	X	
COMSMT Naval and Air Base, COM Infantry Brigade – COLEGION, Central ADM Director	X	X	X	X	

B. AGAINST NON-COMMISSIONED OFFICERS

AUTHORITIES	SANCTIONS			
	Disciplinary measures		Administrative	
	Warning	Reprimand	Warning (b)	Minors
SED-CEMA- CGA-IGA- Chief of Army Staff – COLOG- Central Directors – COMCNSP – COMRMIA- COMRGEND - COMRSM	X	X	X	X
Senior Officer, Formation, Legion, Sector or Academy Commander, Junior Officer, Arms Commander, Unit Commander	X	X	X	

C. AGAINST THE RANK AND FILE

AUTHORITIES	SANCTIONS			
	Disciplinary measures	Administrative		Statutory
	Warning (a)	Minors	Majors	Demotion to 2 nd Class
SED-CEMA- CGA-IGA- Army Chief of Staff – COLOG- Central Directors – COMCNSP – COMRMIA- COMRGEND - COMRSM		X	X	X
Senior Officer, Formation, Legion, Sector or Academy Commander, Junior Officer, Arms Commander, Unit Commander	X	X		

- a) Warnings are recorded in the punishment register but not in the staff files.
- b) Reprimands and warnings are recorded, with the reasons, in the staff file.

VOLUME 4
PENSIONS OF MILITARY PERSONNEL

PENSION PROCEDURES

OFFICER'S PENSION

1. GRANTING A RETIREMENT PENSION
2. GRANTING OF A RETIREMENT PENSION AND REVALORISATION OF A LIFE-LONG INVALIDITY PENSION
3. GRANTING OF A RETIREMENT PENSION, REVALORISATION OF A LIFE-LONG INVALIDITY PENSION AND GRANTING OF AN INSTALLATION ALLOWANCE
4. GRANTING OF A RETIREMENT PENSION AND REVALORISATION OF A LIFE-LONG INVALIDITY PENSION AND ALLOCATION OF BENEFITS FROM THE MOBILISABLE RESERVE
5. GRANTING A RETIREMENT PENSION AND A TEMPORARY INVALIDITY PENSION
6. GRANTING OF A RETIREMENT PENSION, REVALORISATION OF A LIFE-LONG INVALIDITY PENSION, ALLOCATION OF BENEFITS FROM THE MOBILISABLE RESERVE AND GRANTING OF AN INSTALLATION ALLOWANCE
7. ALLOCATING BENEFITS FROM THE MOBILISABLE RESERVE
8. GRANTING AND REVERSION OF A RETIREMENT PENSION, REVALORISATION AND REVERSION OF A LIFE-LONG INVALIDITY PENSION, ALLOCATION AND REVERSION OF BENEFITS FROM THE MOBILISABLE RESERVE
9. GRANTING A LIFE-LONG INVALIDITY PENSION
10. GRANTING A TEMPORARY INVALIDITY PENSION
11. GRANTING DEATH BENEFITS AND A REVERSIONARY PENSION
12. GRANTING DEATH BENEFITS, A REVERSIONARY PENSION AND REVERSION OF A LIFE-LONG INVALIDITY PENSION
13. GRANTING ORPHAN'S TEMPORARY PENSION
14. GRANTING DEATH BENEFITS AND ORPHAN'S TEMPORARY PENSION

15. GRANTING OF DEATH BENEFITS, TEMPORARY ORPHAN'S PENSION AND REVERSION OF A LIFE-LONG INVALIDITY PENSION
16. GRANTING A REVERSIONARY PENSION
17. GRANTING AND REVERSION OF A LIFE-LONG INVALIDITY PENSION
18. GRANTING DEATH BENEFITS AND SURVIVOR'S PENSION
19. REIMBURSEMENT OF PENSION DEDUCTIONS
20. GRANTING DEATH BENEFITS
21. GRANTING TECHNICAL ALLOWANCE
22. GRANTING VEHICLE MAINTENANCE ALLOWANCE

NON-COMMISSIONED PERSONNEL PENSION

23. GRANTING A RETIREMENT PENSION
24. GRANTING OF A RETIREMENT PENSION AND REVALORISATION OF A LIFE-LONG INVALIDITY PENSION
25. GRANTING OF A RETIREMENT PENSION, REVALORISATION OF A LIFE-LONG INVALIDITY PENSION AND GRANTING OF AN INSTALLATION ALLOWANCE
26. GRANTING OF A RETIREMENT PENSION, REVALORISATION OF A LIFE-LONG INVALIDITY PENSION AND ALLOCATION OF BENEFITS FROM THE MOBILISABLE RESERVE
27. GRANTING A RETIREMENT PENSION AND A LIFE-LONG INVALIDITY PENSION

28. GRANTING A RETIREMENT PENSION AND A TEMPORARY INVALIDITY PENSION
29. GRANTING OF A RETIREMENT PENSION, REVALORISATION OF A LIFE-LONG INVALIDITY PENSION, ALLOCATION OF BENEFITS FROM THE MOBILISABLE RESERVE AND GRANTING OF AN INSTALLATION ALLOWANCE
30. ALLOCATING BENEFITS FROM THE MOBILISABLE RESERVE
31. GRANTING AND REVERSION OF A RETIREMENT PENSION, REVALORISATION AND REVERSION OF A LIFE-LONG INVALIDITY PENSION, ALLOCATION AND REVERSION OF BENEFITS FROM THE MOBILISABLE RESERVE
32. GRANTING A LIFE-LONG INVALIDITY PENSION
33. GRANTING A TEMPORARY INVALIDITY PENSION
34. GRANTING DEATH BENEFITS AND A REVERSIONARY PENSION
35. GRANTING DEATH BENEFITS, A REVERSIONARY PENSION AND REVERSION OF A LIFE-LONG INVALIDITY PENSION
36. GRANTING ORPHAN'S TEMPORARY PENSION
37. GRANTING DEATH BENEFITS AND ORPHAN'S TEMPORARY PENSION
38. GRANTING DEATH BENEFITS, ORPHAN'S TEMPORARY PENSION AND REVERSION OF A LIFE-LONG INVALIDITY PENSION
39. GRANTING A REVERSIONARY PENSION
40. GRANTING AND REVERSION OF A LIFE-LONG INVALIDITY PENSION
41. GRANTING DEATH BENEFITS AND SURVIVOR'S PENSION
42. REIMBURSEMENT OF PENSION DEDUCTIONS
43. AUTHORISING PAYMENT OF WAGES AND REIMBURSEMENT OF PENSION DEDUCTIONS
44. GRANTING DEATH BENEFITS

OFFICER'S PENSION

NOTA BENE: In principle, placing an officer on retirement is by Presidential Decree, be it individual or collective. This instrument is initiated by the Department of Human Resource. However, in some specific cases, a single instrument puts the officer on retirement and grants him/her the retirement pension and accompanying advantages at the same time. This is the case for example when the officer is released from military obligations (**Final Reform No. 1**), after a session of the Reform Commission.

**PROCEDURE No. 01/MINDEF/DAAR/PO/I
GRANTING A RETIREMENT PENSION**

TITLE OF THE INSTRUMENT: Decree granting a retirement pension to an officer

INITIATOR OF THE PROCEDURE: Applicant

INITIATING ENTITY: Pensions Service

PLACE OF SUBMISSION OF FILE: Base unit

REFERENCE INSTRUMENTS:

- Law No. 67/LF/9 of 12 June 1967 on the general organisation of Defence;
- Law No. 80/12 of 14 July 1980 on general rules and regulations governing servicemen, together with all the amendments thereto;
- Decree No. 76/460 of 12 October 1976 to organise military pension schemes based on longevity of service and invalidity pensions, as amended by Decree No. 86/262 of 26 March 1986;
- Decree No. 72/DF/108 of 26 February 1972 to amend Decree No. 70/DF/318 of 23 June 1970 amending Decree No. 69/DF/228 of 09 June 1969 relating to the elements of remuneration of civilian and military personnel of the Federal Public Service;
- Decree No. 78/488 of 09 November 1978 defining the terms and conditions for the award of civilian and military pensions, life annuities, death grants and death compensation;
- Decree No. 80/257 of 15 July 1980 to lay down general rules and regulations governing the remuneration schemes applicable to military personnel of the Armed Forces, as amended by Decree No. 84/926 of 30 July 1984;
- Decree No. 82/341 of 09 August 1982 to lay down the conditions for granting death benefits;
- Decree No. 85/1092 of 02 August 1985 revalorising civilian and military pensions;
- Decree No. 2001/178 of 25 July 2001 on the general organisation of Defence and Central Staff;
- Decree No. 2001/188 of 25 July 2001 to lay down special rules and regulations governing the corps of Active Officers of the Defence Forces;
- Decree No. 2008/099 of 07 March 2008 to revalorise the basic monthly salaries of civilian and military personnel;
- Decree No. 2008/311 of 27 August 2008 granting an annuity bonus to some military personnel of the Defence Forces;
- Decree No. 2010/239 of 10 August 2010 amending the retirement of some Officers of the Defence Forces;
- Decree No. 2011/412 of 09 December 2011 to reorganise the Presidency of the Republic;
- Decree No. 2014/253 of 07 July 2014 to revalorise the basic monthly salaries of civilian and military personnel;
- Decree No. 2015/194 of 20 April 2015 granting an annuity bonus to some military personnel of the Defence Forces;
- Decree No. 2016/034 of 21 January 2016 to revalorise family allowances;
- Decree No. 2018/190 of 02 March 2018 amending and supplementing certain provisions of Decree No. 2011/408 of 09 December 2011 to organise the Government;
- Decree No. 2019/002 of 04 January 2019 to reshuffle the Government;
- Order No. 236/CAB/PR of 09 November 1978 laying down the procedure for granting civilian and military pensions, life annuities, death grants and death compensation.

REQUIREMENT: Be a retired officer with at least 15 years of service.

CONSTITUTION OF FILE:*** Required documents:**

- stamped application on *papier ministre* (ledger square paper) addressed to the Minister;
- retirement decree;
- military service record;
- certificate of residence;
- certified copy of valid national identity card of the applicant;
- certified copy of birth certificate;
- certified photocopies of his/her children's birth certificates (in the case of a recognised child, the page bearing the mention of recognition must be certified);
- collective life certificate of all the children;
- original copies of school certificates of minor children for the current year;
- original copy of bank account certificate;
- last payslip with salary;
- copy of marriage certificate or certificate of celibacy;
- photocopy of divorce judgement and certificate of non-appeal or death certificate of the spouse (where applicable);
- certificate of individuality (where applicable);
- certificate of conformity of date of birth (where applicable).

Reference documents: Staff file







DEADLINE: Sixty (60) days

SIGNATORY OF THE INSTRUMENT: the President of the Republic

DELIVERY METHOD: Collection

QUALITY SUPERVISOR: the Director of Administrative and Regulatory Affairs

PROCESSING

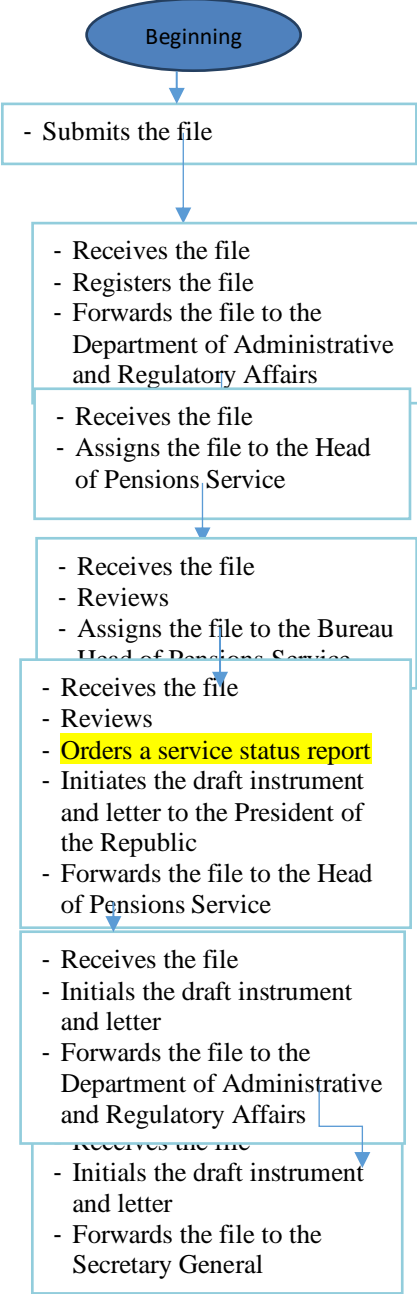
DEPARTMENT OF ADMINISTRATIVE AND REGULATORY AFFAIRS	PROCEDURE No. 01/MINDEF/DAAR/PO/I GRANTING A RETIREMENT PENSION	Procedure start date: 2023	
		Procedure version:	
		Deadline	Page
<i>Intervening parties</i>	<i>Stages</i>		<i>Handling rules</i>
 Applicant  Base unit  DAAR  CSP  CBPS/CSPI  CSP  DAAR			<p>R1: Check file's compliance</p> <p>R2: Check the authenticity of information provided</p> <p>R3: Ensure that the applicant is eligible</p> <p>R4: Ensure procedure consistency</p>

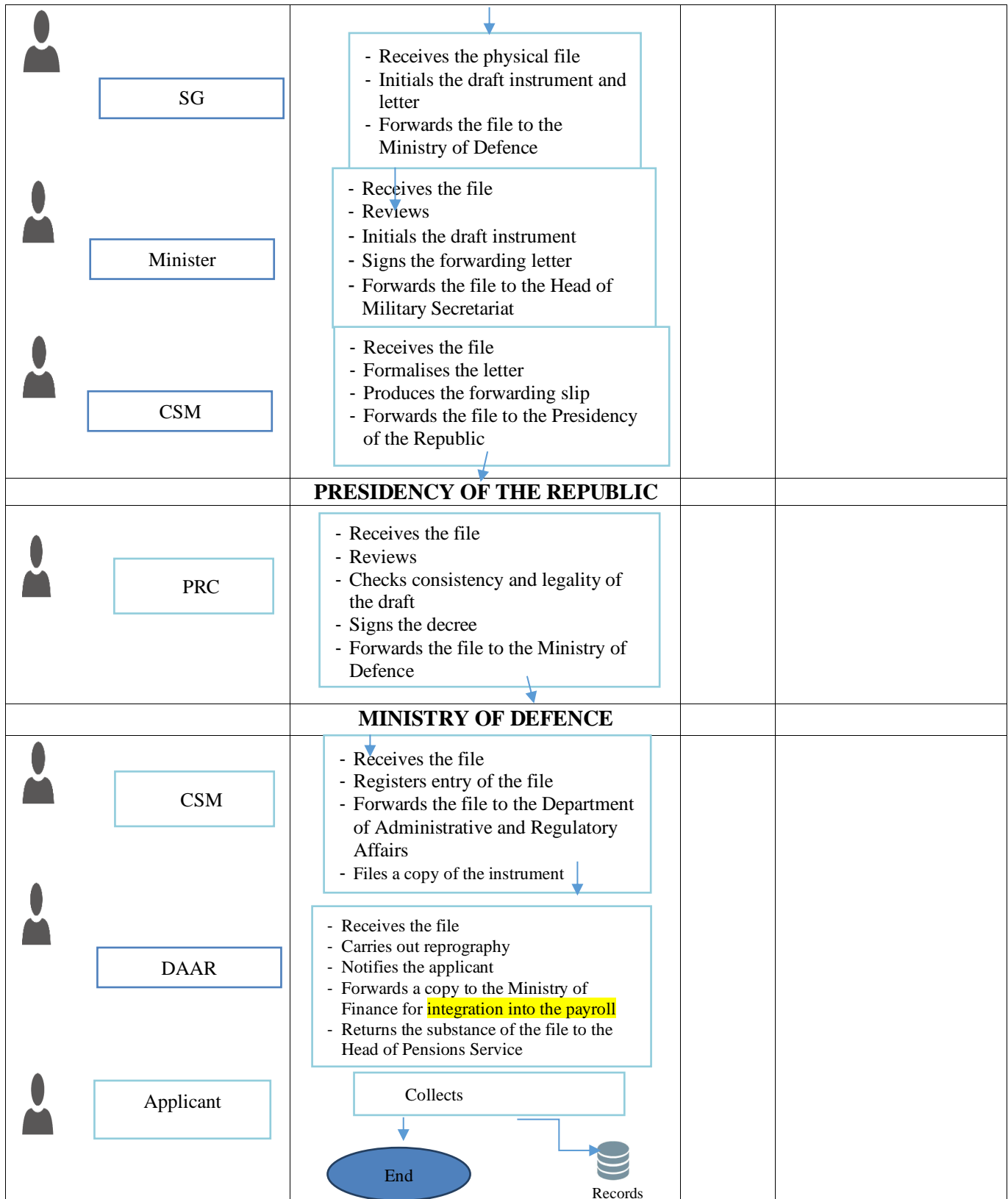

*PROCEDURE No. 02/MINDEF/DAAR/PO/I***GRANTING OF A RETIREMENT PENSION AND REVALORISATION
OF A LIFE-LONG INVALIDITY PENSION**

TITLE OF THE INSTRUMENT: Decree on the granting of a retirement pension and revalorisation of a life-long invalidity pension

INITIATOR OF THE PROCEDURE: Applicant

INITIATING ENTITY: Pensions Service

PLACE OF SUBMISSION OF FILE: Base unit

REFERENCE INSTRUMENTS:

- Law No. 67/LF/9 of 12 June 1967 on the general organisation of Defence;
- Law No. 80/12 of 14 July 1980 on general rules and regulations governing servicemen, together with all the amendments thereto;
- Decree No. 76/460 of 12 October 1976 to organise military pension schemes based on longevity of service and invalidity pensions, as amended by Decree No. 86/262 of 26 March 1986;
- Decree No. 78/488 of 09 November 1978 defining the terms and conditions for granting civilian and military pensions, life annuities, death grants and death compensation;
- Decree No. 80/257 of 15 July 1980 to lay down general rules and regulations governing the remuneration schemes applicable to military personnel of the Armed Forces, as amended by Decree No. 84/926 of 30 July 1984;
- Decree No. 82/341 of 09 August 1982 to lay down the conditions for granting death benefits;
- Decree No. 85/1092 of 02 August 1985 revalorising civilian and military pensions;
- Decree No. 2001/178 of 25 July 2001 on the general organisation of Defence and Central Staff;
- Decree No. 2001/188 of 25 July 2001 to lay down special rules and regulations governing the corps of Active Officers of the Defence Forces;
- Decree No. 2008/099 of 07 March 2008 to revalorise the basic monthly salaries of civilian and military personnel;
- Decree No. 2008/311 of 27 August 2008 granting an annuity bonus to some military personnel of the Defence Forces;
- Decree No. 2010/239 of 10 August 2010 amending the retirement of some Officers of the Defence Forces;
- Decree No. 2011/412 of 09 December 2011 to reorganise the Presidency of the Republic;
- Decree No. 2014/253 of 07 July 2014 to revalorise the basic monthly salaries of civilian and military personnel;
- Decree No. 2015/194 of 20 April 2015 granting an annuity bonus to some military personnel of the Defence Forces;
- Decree No. 2016/034 of 21 January 2016 to revalorise family allowances;
- Decree No. 2018/190 of 02 March 2018 amending and supplementing certain provisions of Decree No. 2011/408 of 09 December 2011 to organise the Government;
- Decree No. 2019/002 of 04 January 2019 to reshuffle the Government;
- Order No. 236/CAB/PR of 09 November 1978 laying down the procedure for granting civilian and military pensions, life annuities, death grants and death compensation.

REQUIREMENT: Be a retired officer with at least 15 years of service and entitled to an invalidity pension.

CONSTITUTION OF FILE:

- **Required documents:**
 - stamped application on *papier ministre* (ledger square paper) addressed to the Minister;
 - retirement decree and attestation of payment from the mobilisable reserve;
 - military service record;
 - certificate of residence;
 - certified copy of valid national identity card of the applicant;
 - certified copy of birth certificate;
 - certified photocopies of his/her children's birth certificates (in the case of a recognised child, the page bearing the mention of recognition must be certified);
 - collective life certificate of all the children;
 - original copies of school certificates of minor children for the current year;
 - original copy of bank account certificate;
 - last payslip with salary;
 - copy of marriage certificate or certificate of celibacy;
 - photocopy of divorce judgement and certificate of non-appeal or death certificate of the spouse;
 - certificate of individuality (where applicable);
- order granting invalidity pension or copy of the Ministerial Decision on the invalidity of some personnel of the Defence Forces;
- certificate of conformity of date of birth (where applicable).
- **Reference documents:** *Staff file*

DEADLINE: Sixty (60) days

SIGNATORY OF THE INSTRUMENT: the President of the Republic

DELIVERY METHOD: Collection

QUALITY SUPERVISOR: the Director of Administrative and Regulatory Affairs

**PROCESSING: cf. processing chain: PROCEDURE No. 01/MINDEF/DAAR/PO/I
GRANTING A RETIREMENT PENSION**

PROCEDURE No. 03/MINDEF/DAAR/PO/I
**GRANTING OF A RETIREMENT PENSION, REVALORISATION OF
A LIFE-LONG INVALIDITY PENSION AND GRANTING OF AN
INSTALLATION ALLOWANCE**

TITLE OF THE INSTRUMENT: Decree on the granting of a retirement pension, revalorisation of a life-long invalidity pension and granting of an installation allowance

INITIATOR OF THE PROCEDURE: Applicant

INITIATING ENTITY: Pensions Service

PLACE OF SUBMISSION OF FILE: Base unit

REFERENCE INSTRUMENTS:

- Law No. 67/LF/9 of 12 June 1967 on the general organisation of Defence;
- Law No. 80/12 of 14 July 1980 on general rules and regulations governing servicemen, together with all the amendments thereto;
- Decree No. 76/460 of 12 October 1976 to organise military pension schemes based on longevity of service and invalidity pensions, as amended by Decree No. 86/262 of 26 March 1986;
- Decree No. 78/488 of 09 November 1978 defining the terms and conditions for granting civilian and military pensions, life annuities, death grants and death compensation;
- Decree No. 80/257 of 15 July 1980 to lay down general rules and regulations governing the remuneration schemes applicable to military personnel of the Armed Forces, as amended by Decree No. 84/926 of 30 July 1984;
- Decree No. 82/341 of 09 August 1982 to lay down the conditions for granting death benefits;
- Decree No. 85/1092 of 02 August 1985 revalorising civilian and military pensions;
- Decree No. 2001/178 of 25 July 2001 on the general organisation of Defence and Central Staff;
- Decree No. 2001/188 of 25 July 2001 to lay down special rules and regulations governing the corps of Active Officers of the Defence Forces;
- Decree No. 2008/099 of 07 March 2008 to revalorise the basic monthly salaries of civilian and military personnel;
- Decree No. 2008/311 of 27 August 2008 granting an annuity bonus to some military personnel of the Defence Forces;
- Decree No. 2010/239 of 10 August 2010 amending the retirement of some Officers of the Defence Forces;
- Decree No. 2011/412 of 09 December 2011 to reorganise the Presidency of the Republic;
- Decree No. 2014/253 of 07 July 2014 to revalorise the basic monthly salaries of civilian and military personnel;
- Decree No. 2015/194 of 20 April 2015 granting an annuity bonus to some military personnel of the Defence Forces;
- Decree No. 2016/034 of 21 January 2016 to revalorise family allowances;
- Decree No. 2018/190 of 02 March 2018 amending and supplementing certain provisions of Decree No. 2011/408 of 09 December 2011 to organise the Government;
- Decree No. 2019/002 of 04 January 2019 to reshuffle the Government;
- Order No. 236/CAB/PR of 09 November 1978 laying down the procedure for granting civilian and military pensions, life annuities, death grants and death compensation.

REQUIREMENT: Be an officer who retired early, with at least 15 years of service and entitled to an invalidity pension.

CONSTITUTION OF FILE:

- **Required documents:**
 - stamped application on *papier ministre* (ledger square paper) addressed to the Minister;
 - order granting invalidity pension or copy of the Ministerial Decision on the invalidity of some personnel of the Defence Forces;
 - early retirement decree;
 - military service record;
 - certificate of residence;
 - certified copy of valid national identity card of the applicant;
 - certified copy of birth certificate;
 - certified photocopies of his/her children's birth certificates (in the case of a recognised child, the page bearing the mention of recognition must be certified);
 - collective life certificate of all the children;
 - original copies of school certificates of minor children for the current year;
 - original copy of bank account certificate;
 - last payslip with salary;
 - copy of marriage certificate or certificate of celibacy;
 - photocopy of divorce judgement and certificate of non-appeal or death certificate of the spouse;
 - certificate of individuality (where applicable);
 - certificate of conformity of date of birth (where applicable).
 - invalidity pension payslip (where applicable).
- **Reference document:** Staff file

DEADLINE: Sixty (60) days

SIGNATORY OF THE INSTRUMENT: the President of the Republic

DELIVERY METHOD: Collection

QUALITY SUPERVISOR: the Director of Administrative and Regulatory Affairs

**PROCESSING: cf. processing chain: PROCEDURE No. 01/MINDEF/DAAR/PO/I
GRANTING A RETIREMENT PENSION**

PROCEDURE No. 04/MINDEF/DAAR/PO/I
**GRANTING OF A RETIREMENT PENSION, REVALORISATION OF A
LIFE-LONG INVALIDITY PENSION AND ALLOCATION OF BENEFITS
FROM THE MOBILISABLE RESERVE**

TITLE OF THE INSTRUMENT: Decree on the granting of a retirement pension, revalorisation of a life-long invalidity pension and allocation of benefits from the mobilisable reserve

INITIATOR OF THE PROCEDURE: Applicant

INITIATING ENTITY: Pensions Service

PLACE OF SUBMISSION OF FILE: Base unit

REFERENCE INSTRUMENTS:

- Law No. 67/LF/9 of 12 June 1967 on the general organisation of Defence;
- Law No. 80/12 of 14 July 1980 on general rules and regulations governing servicemen, together with all the amendments thereto;
- Decree No. 76/460 of 12 October 1976 to organise military pension schemes based on longevity of service and invalidity pensions, as amended by Decree No. 86/262 of 26 March 1986;
- Decree No. 78/488 of 09 November 1978 defining the terms and conditions for granting civilian and military pensions, life annuities, death grants and death compensation;
- Decree No. 80/257 of 15 July 1980 to lay down general rules and regulations governing the remuneration schemes applicable to military personnel of the Armed Forces, as amended by Decree No. 84/926 of 30 July 1984;
- Decree No. 82/341 of 09 August 1982 to lay down the conditions for granting death benefits;
- Decree No. 85/1092 of 02 August 1985 revalorising civilian and military pensions;
- Decree No. 2001/178 of 25 July 2001 on the general organisation of Defence and Central Staff;
- Decree No. 2001/188 of 25 July 2001 to lay down special rules and regulations governing the corps of Active Officers of the Defence Forces;
- Decree No. 2008/099 of 07 March 2008 to revalorise the basic monthly salaries of civilian and military personnel;
- Decree No. 2008/311 of 27 August 2008 granting an annuity bonus to some military personnel of the Defence Forces;
- Decree No. 2010/239 of 10 August 2010 amending the retirement of some Officers of the Defence Forces;
- Decree No. 2011/412 of 09 December 2011 to reorganise the Presidency of the Republic;
- Decree No. 2014/253 of 07 July 2014 to revalorise the basic monthly salaries of civilian and military personnel;
- Decree No. 2015/194 of 20 April 2015 granting an annuity bonus to some military personnel of the Defence Forces;
- Decree No. 2016/034 of 21 January 2016 to revalorise family allowances;
- Decree No. 2018/190 of 02 March 2018 amending and supplementing certain provisions of Decree No. 2011/408 of 09 December 2011 to organise the Government;
- Decree No. 2019/002 of 04 January 2019 to reshuffle the Government;
- Order No. 236/CAB/PR of 09 November 1978 laying down the procedure for granting civilian and military pensions, life annuities, death grants and death compensation.

REQUIREMENT: Be an officer who retired early, with at least 15 years of service, entitled to an invalidity pension and admitted to the mobilisable reserve.

CONSTITUTION OF FILE:

- **Required documents:**
 - stamped application on papier ministre (ledger square paper) addressed to the Minister;
 - order granting invalidity pension or copy of the Ministerial Decision on the invalidity of some personnel of the Defence Forces;
 - decree constituting the retirement pension;
 - decree on payment from the mobilisable reserve;
 - military service record;
 - certificate of residence;
 - certified copy of valid national identity card of the applicant;
 - certified copy of birth certificate;
 - certified photocopies of his/her children's birth certificates (in the case of a recognised child, the page bearing the mention of recognition must be certified);
 - collective life certificate of all the children;
 - original copies of school certificates of minor children for the current year;
 - original copy of bank account certificate;
 - last payslip with salary;
 - copy of marriage certificate or certificate of celibacy;
 - photocopy of divorce judgement and certificate of non-appeal or death certificate of the spouse;
 - certificate of individuality (where applicable);
 - certificate of conformity of date of birth (where applicable);
 - invalidity pension payslip (where applicable).
- **Reference document:** *Staff file*

DEADLINE: Sixty (60) days

SIGNATORY OF THE INSTRUMENT: the President of the Republic

DELIVERY METHOD: Collection

QUALITY SUPERVISOR: the Director of Administrative and Regulatory Affairs

PROCESSING: cf. processing chain: **PROCEDURE No. 01/MINDEF/DAAR/PO/I GRANTING A RETIREMENT PENSION**

**PROCEDURE No. 05/MINDEF/DAAR/PO/I
GRANTING A RETIREMENT PENSION AND A TEMPORARY
INVALIDITY PENSION**

TITLE OF THE INSTRUMENT: Decree granting a retirement pension and a temporary invalidity pension

INITIATOR OF THE PROCEDURE: Applicant

INITIATING ENTITY: Pensions Service

PLACE OF SUBMISSION OF FILE: Base unit

REFERENCE INSTRUMENTS:

- Law No. 67/LF/9 of 12 June 1967 on the general organisation of Defence;
- Law No. 80/12 of 14 July 1980 on general rules and regulations governing servicemen, together with all the amendments thereto;
- Decree No. 76/460 of 12 October 1976 to organise military pension schemes based on longevity of service and invalidity pensions, as amended by Decree No. 86/262 of 26 March 1986;
- Decree No. 78/488 of 09 November 1978 defining the terms and conditions for granting civilian and military pensions, life annuities, death grants and death compensation;
- Decree No. 80/257 of 15 July 1980 to lay down general rules and regulations governing the remuneration schemes applicable to military personnel of the Armed Forces, as amended by Decree No. 84/926 of 30 July 1984;
- Decree No. 82/341 of 09 August 1982 to lay down the conditions for granting death benefits;
- Decree No. 85/1092 of 02 August 1985 revalorising civilian and military pensions;
- Decree No. 2001/178 of 25 July 2001 on the general organisation of Defence and Central Staff;
- Decree No. 2001/188 of 25 July 2001 to lay down special rules and regulations governing the corps of Active Officers of the Defence Forces;
- Decree No. 2008/099 of 07 March 2008 to revalorise the basic monthly salaries of civilian and military personnel;
- Decree No. 2008/311 of 27 August 2008 granting an annuity bonus to some military personnel of the Defence Forces;
- Decree No. 2010/239 of 10 August 2010 amending the retirement of some Officers of the Defence Forces;
- Decree No. 2011/412 of 09 December 2011 to reorganise the Presidency of the Republic;
- Decree No. 2014/253 of 07 July 2014 to revalorise the basic monthly salaries of civilian and military personnel;
- Decree No. 2015/194 of 20 April 2015 granting an annuity bonus to some military personnel of the Defence Forces;
- Decree No. 2016/034 of 21 January 2016 to revalorise family allowances;
- Decree No. 2018/190 of 02 March 2018 amending and supplementing certain provisions of Decree No. 2011/408 of 09 December 2011 to organise the Government;
- Decree No. 2019/002 of 04 January 2019 to reshuffle the Government;
- Order No. 236/CAB/PR of 09 November 1978 laying down the procedure for granting civilian and military pensions, life annuities, death grants and death compensation.

REQUIREMENT: Be a retired officer with at least 15 years of service and entitled to a temporary invalidity pension.

CONSTITUTION OF FILE:

- **Required documents:**
 - stamped application on *papier ministre* (ledger square paper) addressed to the Minister;
 - retirement decree;
 - military service record;
 - certificate of residence;
 - Ministerial Decision on the invalidity of some personnel of the Defence Forces;

- certified copy of valid national identity card of the applicant;
- certified copy of birth certificate;
- certified photocopies of his/her children's birth certificates (in the case of a recognised child, the page bearing the mention of recognition must be certified);
- collective life certificate of all the children;
- original copies of school certificates of minor children for the current year;
- original copy of bank account certificate;
- last payslip with salary;
- copy of marriage certificate or certificate of celibacy;
- photocopy of divorce judgement and certificate of non-appeal or death certificate of the spouse;
- certificate of individuality (where applicable);
- certificate of conformity of date of birth (where applicable);
- invalidity pension payslip (where applicable).

- **Reference documents:** Staff file

DEADLINE: Sixty (60) days

SIGNATORY OF THE INSTRUMENT: the President of the Republic

DELIVERY METHOD: Collection

QUALITY SUPERVISOR: the Director of Administrative and Regulatory Affairs

PROCESSING: cf. processing chain: **PROCEDURE No. 01/MINDEF/DAAR/PO/I**
GRANTING A RETIREMENT PENSION

PROCEDURE No. 06/MINDEF/DAAR/PO/1
**GRANTING OF A RETIREMENT PENSION, REVALORISATION OF A LIFE-
LONG INVALIDITY PENSION, ALLOCATION OF BENEFITS FROM THE
MOBILISABLE RESERVE AND GRANTING OF AN INSTALLATION
ALLOWANCE**

TITLE OF THE INSTRUMENT: Decree on the granting of a retirement pension, revalorisation of a life-long invalidity pension, allocation of benefits from the mobilisable reserve and granting of an installation allowance

INITIATOR OF THE PROCEDURE: Applicant

INITIATING ENTITY: Pensions Service

PLACE OF SUBMISSION OF FILE: Base unit

REFERENCE INSTRUMENTS:

- Law No. 67/LF/9 of 12 June 1967 on the general organisation of Defence;
- Law No. 80/12 of 14 July 1980 on general rules and regulations governing servicemen, together with all the amendments thereto;
- Decree No. 76/460 of 12 October 1976 to organise military pension schemes based on longevity of service and invalidity pensions, as amended by Decree No. 86/262 of 26 March 1986;
- Decree No. 78/488 of 09 November 1978 defining the terms and conditions for granting civilian and military pensions, life annuities, death grants and death compensation;
- Decree No. 80/257 of 15 July 1980 to lay down general rules and regulations governing the remuneration schemes applicable to military personnel of the Armed Forces, as amended by Decree No. 84/926 of 30 July 1984;
- Decree No. 82/341 of 09 August 1982 to lay down the conditions for granting death benefits;
- Decree No. 85/1092 of 02 August 1985 revalorising civilian and military pensions;
- Decree No. 2001/178 of 25 July 2001 on the general organisation of Defence and Central Staff;
- Decree No. 2001/188 of 25 July 2001 to lay down special rules and regulations governing the corps of Active Officers of the Defence Forces;
- Decree No. 2008/099 of 07 March 2008 to revalorise the basic monthly salaries of civilian and military personnel;
- Decree No. 2008/311 of 27 August 2008 granting an annuity bonus to some military personnel of the Defence Forces;
- Decree No. 2010/239 of 10 August 2010 amending the retirement of some Officers of the Defence Forces;
- Decree No. 2011/412 of 09 December 2011 to reorganise the Presidency of the Republic;
- Decree No. 2014/253 of 07 July 2014 to revalorise the basic monthly salaries of civilian and military personnel;
- Decree No. 2015/194 of 20 April 2015 granting an annuity bonus to some military personnel of the Defence Forces;
- Decree No. 2016/034 of 21 January 2016 to revalorise family allowances;
- Decree No. 2018/190 of 02 March 2018 amending and supplementing certain provisions of Decree No. 2011/408 of 09 December 2011 to organise the Government;
- Decree No. 2019/002 of 04 January 2019 to reshuffle the Government;
- Order No. 236/CAB/PR of 09 November 1978 laying down the procedure for granting civilian and military pensions, life annuities, death grants and death compensation.

REQUIREMENT: Be a retired officer with at least 15 years of service, entitled to an invalidity pension and admitted to the mobilisable reserve.

CONSTITUTION OF FILE:

• **Required documents:**

- stamped application on *papier ministre* (ledger square paper) addressed to the Minister;
- order granting invalidity pension or copy of the Ministerial Decision on the invalidity of some personnel of the Defence Forces;

- early retirement decree;
- military service record;
- certificate of residence;
- certified copy of valid national identity card of the applicant;
- certified copy of birth certificate;
- certified photocopies of his/her children's birth certificates (in the case of a recognised child, the page bearing the mention of recognition must be certified);
- collective life certificate of all the children;
- original copies of school certificates of minor children for the current year;
- original copy of bank account certificate;
- last payslip with salary;
- copy of marriage certificate or certificate of celibacy;
- photocopy of divorce judgement and certificate of non-appeal or death certificate of the spouse;
- certificate of individuality (where applicable);
- certificate of conformity of date of birth (where applicable);
- invalidity pension payslip (where applicable);
- decree on payment from the mobilisable reserve;
- invalidity pension payslip (where applicable).

- **Reference documents:** Staff file

DEADLINE: Sixty (60) days

SIGNATORY OF THE INSTRUMENT: the President of the Republic

DELIVERY METHOD: Collection

QUALITY SUPERVISOR: the Director of Administrative and Regulatory Affairs

PROCESSING: cf. processing chain: **PROCEDURE No. 01/MINDEF/DAAR/PO/I
GRANTING A RETIREMENT PENSION**

**PROCEDURE No. 07/MINDEF/DAAR/PO/I
ALLOCATING BENEFITS FROM THE MOBILISABLE RESERVE**

TITLE OF THE INSTRUMENT: Decree allocating benefits from the mobilisable reserve

INITIATOR OF THE PROCEDURE: Applicant

INITIATING ENTITY: Pensions Service

PLACE OF SUBMISSION OF FILE: Base unit

REFERENCE INSTRUMENTS:

- Law No. 67/LF/9 of 12 June 1967 on the general organisation of Defence;
- Law No. 80/12 of 14 July 1980 on general rules and regulations governing servicemen, together with all the amendments thereto;
- Decree No. 76/460 of 12 October 1976 to organise military pension schemes based on longevity of service and invalidity pensions, as amended by Decree No. 86/262 of 26 March 1986;
- Decree No. 78/488 of 09 November 1978 defining the terms and conditions for granting civilian and military pensions, life annuities, death grants and death compensation;
- Decree No. 80/257 of 15 July 1980 to lay down general rules and regulations governing the remuneration schemes applicable to military personnel of the Armed Forces, as amended by Decree No. 84/926 of 30 July 1984;
- Decree No. 82/341 of 09 August 1982 to lay down the conditions for granting death benefits;
- Decree No. 85/1092 of 02 August 1985 revalorising civilian and military pensions;
- Decree No. 2001/178 of 25 July 2001 on the general organisation of Defence and Central Staff;
- Decree No. 2001/188 of 25 July 2001 to lay down special rules and regulations governing the corps of Active Officers of the Defence Forces;
- Decree No. 2008/099 of 07 March 2008 to revalorise the basic monthly salaries of civilian and military personnel;
- Decree No. 2008/311 of 27 August 2008 granting an annuity bonus to some military personnel of the Defence Forces;
- Decree No. 2010/239 of 10 August 2010 amending the retirement of some Officers of the Defence Forces;
- Decree No. 2011/412 of 09 December 2011 to reorganise the Presidency of the Republic;
- Decree No. 2014/253 of 07 July 2014 to revalorise the basic monthly salaries of civilian and military personnel;
- Decree No. 2015/194 of 20 April 2015 granting an annuity bonus to some military personnel of the Defence Forces;
- Decree No. 2016/034 of 21 January 2016 to revalorise family allowances;
- Decree No. 2018/190 of 02 March 2018 amending and supplementing certain provisions of Decree No. 2011/408 of 09 December 2011 to organise the Government;
- Decree No. 2019/002 of 04 January 2019 to reshuffle the Government;
- Order No. 236/CAB/PR of 09 November 1978 laying down the procedure for granting civilian and military pensions, life annuities, death grants and death compensation.

REQUIREMENTS: Be an officer paid from the mobilisable reserve.

CONSTITUTION OF FILE:

- **Required documents:**
 - stamped application on *papier ministre* (ledger square paper) addressed to the Minister;
 - decree on payment from the mobilisable reserve;
 - certificate of residence;
 - certified copy of valid national identity card of the applicant;
 - certified copy of birth certificate;

- certified photocopies of his/her children's birth certificates (in the case of a recognised child, the page bearing the mention of recognition must be certified);
- collective life certificate of all the children;
- original copies of school certificates of minor children for the current year;
- original copy of bank account certificate;
- last payslip with salary;
- copy of marriage certificate or certificate of celibacy;
- photocopy of divorce judgement and certificate of non-appeal or death certificate of the spouse;
- certificate of individuality (where applicable);
- certificate of conformity of date of birth (where applicable);
- invalidity pension payslip (where applicable);
- decree on payment from the mobilisable reserve;
- pension payslip.

- **Reference document:** *Staff file*

DEADLINE: Sixty (60) days

SIGNATORY OF THE INSTRUMENT: the President of the Republic

DELIVERY METHOD: Posting/Collection

QUALITY SUPERVISOR: the Director of Administrative and Regulatory Affairs

PROCESSING: cf. processing chain: **PROCEDURE No. 01/MINDEF/DAAR/PO/I**
GRANTING A RETIREMENT PENSION

PROCEDURE No. 08/MINDEF/DAAR/PO/I
**GRANTING AND REVERSION OF A RETIREMENT PENSION,
REVALORISATION AND REVERSION OF A LIFE-LONG INVALIDITY
PENSION, ALLOCATION AND REVERSION OF BENEFITS FROM THE
MOBILISABLE RESERVE**

TITLE OF THE INSTRUMENT: Decree on the granting and reversion of a retirement pension, revalorisation and reversion of a life-long invalidity pension, allocation and reversion of benefits from the mobilisable reserve

INITIATOR OF THE PROCEDURE: Applicant

INITIATING ENTITY: Pensions Service

PLACE OF SUBMISSION OF FILE: Base unit

REFERENCE INSTRUMENTS:

- Law No. 67/LF/9 of 12 June 1967 on the general organisation of Defence;
- Law No. 80/12 of 14 July 1980 on general rules and regulations governing servicemen, together with all the amendments thereto;
- Decree No. 76/460 of 12 October 1976 to organise military pension schemes based on longevity of service and invalidity pensions, as amended by Decree No. 86/262 of 26 March 1986;
- Decree No. 78/488 of 09 November 1978 defining the terms and conditions for granting civilian and military pensions, life annuities, death grants and death compensation;
- Decree No. 80/257 of 15 July 1980 to lay down general rules and regulations governing the remuneration schemes applicable to military personnel of the Armed Forces, as amended by Decree No. 84/926 of 30 July 1984;
- Decree No. 82/341 of 09 August 1982 to lay down the conditions for granting death benefits;
- Decree No. 85/1092 of 02 August 1985 revalorising civilian and military pensions;
- Decree No. 2001/178 of 25 July 2001 on the general organisation of Defence and Central Staff;
- Decree No. 2001/188 of 25 July 2001 to lay down special rules and regulations governing the corps of Active Officers of the Defence Forces;
- Decree No. 2008/099 of 07 March 2008 to revalorise the basic monthly salaries of civilian and military personnel;
- Decree No. 2008/311 of 27 August 2008 granting an annuity bonus to some military personnel of the Defence Forces;
- Decree No. 2010/239 of 10 August 2010 amending the retirement of some Officers of the Defence Forces;
- Decree No. 2011/412 of 09 December 2011 to reorganise the Presidency of the Republic;
- Decree No. 2014/253 of 07 July 2014 to revalorise the basic monthly salaries of civilian and military personnel;
- Decree No. 2015/194 of 20 April 2015 granting an annuity bonus to some military personnel of the Defence Forces;
- Decree No. 2016/034 of 21 January 2016 to revalorise family allowances;
- Decree No. 2018/190 of 02 March 2018 amending and supplementing certain provisions of Decree No. 2011/408 of 09 December 2011 to organise the Government;
- Decree No. 2019/002 of 04 January 2019 to reshuffle the Government;
- Order No. 236/CAB/PR of 09 November 1978 laying down the procedure for granting civilian and military pensions, life annuities, death grants and death compensation;
- Ministerial Decision No. 1002854/DM/MINDEF/01 of 28 September 2010 on the invalidity of some personnel of the National Security and Defence Forces.

REQUIREMENT: Be the heir of a retired officer, paid from the mobilisable reserve who died without receiving his full retirement and invalidity pensions.

CONSTITUTION OF FILE:

• **Required documents:**

- stamped application on *papier ministre* (ledger square paper) addressed to the Minister;
- order granting invalidity pension or copy of the Ministerial Decision on the invalidity of some personnel of the Defence Forces;
- retirement decree and attestation of payment from the mobilisable reserve;
- military service record;
- certificate of residence;
- certified copy of valid national identity card of the applicant;
- certified copy of birth certificate;
- certified photocopies of his/her children's birth certificates (in the case of a recognised child, the page bearing the mention of recognition must be certified);
- collective life certificate of all the children;
- photocopy of inheritance judgement;
- photocopy of non-appeal certificate of the inheritance judgement;
- null payslip of the deceased service member;
- copy of death certificate of the service member (established at the council of the place of death);
- certificate of monogamy or polygamy;
- certificate(s) of non-divorce, non-separation and non-remarriage;
- original copies of school certificates of minor children for the current year;
- original copy of bank account certificate;
- last payslip with salary;
- copy of marriage certificate or certificate of celibacy;
- certificates of non-remarriage, non-separation, non-cohabitation and non-divorce;
- photocopy of divorce judgement and certificate of non-appeal or death certificate of the spouse;
- certificate of individuality (where applicable);
- certificate of conformity of date of birth (where applicable);
- invalidity pension payslip (where applicable);
- invalidity pension payslip (where applicable);
- certificate of conformity of date of birth (where applicable).

- **Reference document:** Staff file

DEADLINE: Sixty (60) days

SIGNATORY OF THE INSTRUMENT: the President of the Republic

DELIVERY METHOD: Collection

QUALITY SUPERVISOR: the Director of Administrative and Regulatory Affairs

PROCESSING: cf. processing chain: **PROCEDURE No. 01/MINDEF/DAAR/PO/I**
GRANTING A RETIREMENT PENSION

**PROCEDURE No. 09/MINDEF/DAAR/PO/I
GRANTING A LIFE-LONG INVALIDITY PENSION**

TITLE OF THE INSTRUMENT: Order granting a life-long invalidity pension

INITIATOR OF THE PROCEDURE: Applicant

INITIATING ENTITY: Pensions Service

PLACE OF SUBMISSION OF FILE: Base unit

REFERENCE INSTRUMENTS:

- Law No. 67/LF/9 of 12 June 1967 on the general organisation of Defence;
- Law No. 80/12 of 14 July 1980 on general rules and regulations governing servicemen, together with all the amendments thereto;
- Decree No. 76/460 of 12 October 1976 to organise military pension schemes based on longevity of service and invalidity pensions, as amended by Decree No. 86/262 of 26 March 1986;
- Decree No. 78/488 of 09 November 1978 defining the terms and conditions for granting civilian and military pensions, life annuities, death grants and death compensation;
- Decree No. 80/257 of 15 July 1980 to lay down general rules and regulations governing the remuneration schemes applicable to military personnel of the Armed Forces, as amended by Decree No. 84/926 of 30 July 1984;
- Decree No. 82/341 of 09 August 1982 to lay down the conditions for granting death benefits;
- Decree No. 85/1092 of 02 August 1985 revalorising civilian and military pensions;
- Decree No. 2001/178 of 25 July 2001 on the general organisation of Defence and Central Staff;
- Decree No. 2001/188 of 25 July 2001 to lay down special rules and regulations governing the corps of Active Officers of the Defence Forces;
- Decree No. 2008/099 of 07 March 2008 to revalorise the basic monthly salaries of civilian and military personnel;
- Decree No. 2008/311 of 27 August 2008 granting an annuity bonus to some military personnel of the Defence Forces;
- Decree No. 2010/239 of 10 August 2010 amending the retirement of some Officers of the Defence Forces;
- Decree No. 2011/412 of 09 December 2011 to reorganise the Presidency of the Republic;
- Decree No. 2014/253 of 07 July 2014 to revalorise the basic monthly salaries of civilian and military personnel;
- Decree No. 2015/194 of 20 April 2015 granting an annuity bonus to some military personnel of the Defence Forces;
- Decree No. 2016/034 of 21 January 2016 to revalorise family allowances;
- Decree No. 2018/190 of 02 March 2018 amending and supplementing certain provisions of Decree No. 2011/408 of 09 December 2011 to organise the Government;
- Decree No. 2019/002 of 04 January 2019 to reshuffle the Government;
- Order No. 236/CAB/PR of 09 November 1978 laying down the procedure for granting civilian and military pensions, life annuities, death grants and death compensation.

REQUIREMENT: Be an officer entitled to an invalidity pension.

CONSTITUTION OF FILE:

• **Required documents:**

- stamped application on *papier ministre* (ledger square paper) addressed to the Minister;
- order granting invalidity pension or copy of the Ministerial Decision on the invalidity of some personnel of the Defence Forces;
- certified copy of valid national identity card of the applicant;
- original copy of bank account certificate;
- certificate of residence;

- certified copy of birth certificate;
- recent payslip;
- certificate of individuality (where applicable);
- certificate of conformity of date of birth (where applicable).

- **Reference document:** Staff file

DEADLINE: Sixty (60) days

SIGNATORY OF THE INSTRUMENT: the President of the Republic

DELIVERY METHOD: Collection

QUALITY SUPERVISOR: the Director of Administrative and Regulatory Affairs

**PROCESSING: cf. processing chain: PROCEDURE No. 01/MINDEF/DAAR/PO/I
GRANTING A RETIREMENT PENSION**

PROCEDURE No. 10/MINDEF/DAAR/PO/I
GRANTING A TEMPORARY INVALIDITY PENSION

TITLE OF THE INSTRUMENT: Order granting a temporary invalidity pension

INITIATOR OF THE PROCEDURE: Applicant

INITIATING ENTITY: Pensions Service

PLACE OF SUBMISSION OF FILE: Base unit

REFERENCE INSTRUMENTS:

- Law No. 67/LF/9 of 12 June 1967 on the general organisation of Defence;
- Law No. 80/12 of 14 July 1980 on general rules and regulations governing servicemen, together with all the amendments thereto;
- Decree No. 76/460 of 12 October 1976 to organise military pension schemes based on longevity of service and invalidity pensions, as amended by Decree No. 86/262 of 26 March 1986;
- Decree No. 78/488 of 09 November 1978 defining the terms and conditions for granting civilian and military pensions, life annuities, death grants and death compensation;
- Decree No. 80/257 of 15 July 1980 to lay down general rules and regulations governing the remuneration schemes applicable to military personnel of the Armed Forces, as amended by Decree No. 84/926 of 30 July 1984;
- Decree No. 82/341 of 09 August 1982 to lay down the conditions for granting death benefits;
- Decree No. 85/1092 of 02 August 1985 revalorising civilian and military pensions;
- Decree No. 2001/178 of 25 July 2001 on the general organisation of Defence and Central Staff;
- Decree No. 2001/188 of 25 July 2001 to lay down special rules and regulations governing the corps of Active Officers of the Defence Forces;
- Decree No. 2008/099 of 07 March 2008 to revalorise the basic monthly salaries of civilian and military personnel;
- Decree No. 2008/311 of 27 August 2008 granting an annuity bonus to some military personnel of the Defence Forces;
- Decree No. 2010/239 of 10 August 2010 amending the retirement of some Officers of the Defence Forces;
- Decree No. 2011/412 of 09 December 2011 to reorganise the Presidency of the Republic;
- Decree No. 2014/253 of 07 July 2014 to revalorise the basic monthly salaries of civilian and military personnel;
- Decree No. 2015/194 of 20 April 2015 granting an annuity bonus to some military personnel of the Defence Forces;
- Decree No. 2016/034 of 21 January 2016 to revalorise family allowances;
- Decree No. 2018/190 of 02 March 2018 amending and supplementing certain provisions of Decree No. 2011/408 of 09 December 2011 to organise the Government;
- Decree No. 2019/002 of 04 January 2019 to reshuffle the Government;
- Order No. 236/CAB/PR of 09 November 1978 laying down the procedure for granting civilian and military pensions, life annuities, death grants and death compensation;
- Ministerial Decision No. 1002854/DM/MINDEF/01 of 28 September 2010 on the invalidity of some personnel of the National Security and Defence Forces.

REQUIREMENT: Be an officer entitled to a temporary invalidity pension.

CONSTITUTION OF FILE:

- **Required documents:**
 - stamped application on *papier ministre* (ledger square paper) addressed to the Minister;
 - Ministerial Decision on the invalidity of some personnel of the Defence Forces;
 - original copy of bank account certificate;
 - certificate of residence;
 - certified copy of birth certificate;
 - recent payslip;
 - certificate of individuality (where applicable);
 - certificate of conformity of date of birth (where applicable);
 - certified copy of valid national identity card of the applicant.
- **Reference document:** Staff file

DEADLINE: Sixty (60) days

SIGNATORY OF THE INSTRUMENT: the President of the Republic

DELIVERY METHOD: Collection

QUALITY SUPERVISOR: the Director of Administrative and Regulatory Affairs

PROCESSING: cf. processing chain: **PROCEDURE No. 01/MINDEF/DAAR/PO/I
GRANTING A RETIREMENT PENSION**

**PROCEDURE No. 11/MINDEF/DAAR/PO/I
GRANTING DEATH BENEFITS AND A REVERSIONARY PENSION**

TITLE OF THE INSTRUMENT : Order granting death benefits and a reversionary pension

INITIATOR OF THE PROCEDURE: Applicant

INITIATING ENTITY: Pensions Service

PLACE OF SUBMISSION OF FILE: Base unit

REFERENCE INSTRUMENTS:

- Law No. 67/LF/9 of 12 June 1967 on the general organisation of Defence;
- Law No. 80/12 of 14 July 1980 on general rules and regulations governing servicemen, together with all the amendments thereto;
- Decree No. 76/460 of 12 October 1976 to organise military pension schemes based on longevity of service and invalidity pensions, as amended by Decree No. 86/262 of 26 March 1986;
- Decree No. 78/488 of 09 November 1978 defining the terms and conditions for granting civilian and military pensions, life annuities, death grants and death compensation;
- Decree No. 80/257 of 15 July 1980 to lay down general rules and regulations governing the remuneration schemes applicable to military personnel of the Armed Forces, as amended by Decree No. 84/926 of 30 July 1984;
- Decree No. 82/341 of 09 August 1982 to lay down the conditions for granting death benefits;
- Decree No. 85/1092 of 02 August 1985 revalorising civilian and military pensions;
- Decree No. 2001/178 of 25 July 2001 on the general organisation of Defence and Central Staff;
- Decree No. 2001/188 of 25 July 2001 to lay down special rules and regulations governing the corps of Active Officers of the Defence Forces;
- Decree No. 2008/099 of 07 March 2008 to revalorise the basic monthly salaries of civilian and military personnel;
- Decree No. 2008/311 of 27 August 2008 granting an annuity bonus to some military personnel of the Defence Forces;
- Decree No. 2010/239 of 10 August 2010 amending the retirement of some Officers of the Defence Forces;
- Decree No. 2011/412 of 09 December 2011 to reorganise the Presidency of the Republic;
- Decree No. 2014/253 of 07 July 2014 to revalorise the basic monthly salaries of civilian and military personnel;
- Decree No. 2015/194 of 20 April 2015 granting an annuity bonus to some military personnel of the Defence Forces;
- Decree No. 2016/034 of 21 January 2016 to revalorise family allowances;
- Decree No. 2018/190 of 02 March 2018 amending and supplementing certain provisions of Decree No. 2011/408 of 09 December 2011 to organise the Government;
- Decree No. 2019/002 of 04 January 2019 to reshuffle the Government;
- Order No. 236/CAB/PR of 09 November 1978 laying down the procedure for granting civilian and military pensions, life annuities, death grants and death compensation;
- Ministerial Decision No. 1002854/DM/MINDEF/01 of 28 September 2010 on the invalidity of some personnel of the National Security and Defence Forces.

REQUIREMENTS: Be the heir of an officer who died in active service.

CONSTITUTION OF FILE:

- **Required documents:**
 - stamped application on *papier ministre* (ledger square paper) addressed to the Minister;
 - military service record;
 - certified photocopy of the spouse’s valid national identity card;
 - certificate of residence;
 - copy(ies) of marriage certificate(s);
 - certificate of monogamy or polygamy;
 - certificate(s) of non-divorce, non-separation and non-remarriage;
 - certified photocopies of his/her children’s birth certificates (in the case of a recognised child, the page bearing the mention of recognition must be certified);
 - collective life certificate of all the children;
 - copy of death certificate of the service member (established at the council of the place of death);
 - original copies of school certificates of minor children for the current year;
 - payslip for the month in which the service member died;
 - null payslip of the deceased service member;
 - photocopy of inheritance judgement;
 - photocopy of non-appeal certificate of the inheritance judgement;
 - certificate of individuality (where applicable);
 - Unit Commander’s report on the circumstances of the death (where applicable);
 - certificate of conformity of date of birth (where applicable);
 - certificates of non-divorce, non-separation and non-remarriage.
- **Reference document:** Staff file

DEADLINE: Sixty (60) days

SIGNATORY OF THE INSTRUMENT: the President of the Republic

DELIVERY METHOD: Collection

QUALITY SUPERVISOR: the Director of Administrative and Regulatory Affairs

PROCESSING: cf. processing chain: **PROCEDURE No. 01/MINDEF/DAAR/PO/I
GRANTING A RETIREMENT PENSION**

PROCEDURE No. 12/MINDEF/DAAR/PO/I
**GRANTING OF DEATH BENEFITS, A REVERSIONARY PENSION AND
REVERSION OF A LIFE-LONG INVALIDITY PENSION**

TITLE OF THE INSTRUMENT: Order on the granting of death benefits, a reversionary pension and reversion of a life-long invalidity pension

INITIATOR OF THE PROCEDURE: Applicant

INITIATING ENTITY: Pensions Service

PLACE OF SUBMISSION OF FILE: Base unit

REFERENCE INSTRUMENTS:

- Law No. 67/LF/9 of 12 June 1967 on the general organisation of Defence;
- Law No. 80/12 of 14 July 1980 on general rules and regulations governing servicemen, together with all the amendments thereto;
- Decree No. 76/460 of 12 October 1976 to organise military pension schemes based on longevity of service and invalidity pensions, as amended by Decree No. 86/262 of 26 March 1986;
- Decree No. 78/488 of 09 November 1978 defining the terms and conditions for granting civilian and military pensions, life annuities, death grants and death compensation;
- Decree No. 80/257 of 15 July 1980 to lay down general rules and regulations governing the remuneration schemes applicable to military personnel of the Armed Forces, as amended by Decree No. 84/926 of 30 July 1984;
- Decree No. 82/341 of 09 August 1982 to lay down the conditions for granting death benefits;
- Decree No. 85/1092 of 02 August 1985 revalorising civilian and military pensions;
- Decree No. 2001/178 of 25 July 2001 on the general organisation of Defence and Central Staff;
- Decree No. 2001/188 of 25 July 2001 to lay down special rules and regulations governing the corps of Active Officers of the Defence Forces;
- Decree No. 2008/099 of 07 March 2008 to revalorise the basic monthly salaries of civilian and military personnel;
- Decree No. 2008/311 of 27 August 2008 granting an annuity bonus to some military personnel of the Defence Forces;
- Decree No. 2010/239 of 10 August 2010 amending the retirement of some Officers of the Defence Forces;
- Decree No. 2011/412 of 09 December 2011 to reorganise the Presidency of the Republic;
- Decree No. 2014/253 of 07 July 2014 to revalorise the basic monthly salaries of civilian and military personnel;
- Decree No. 2015/194 of 20 April 2015 granting an annuity bonus to some military personnel of the Defence Forces;
- Decree No. 2016/034 of 21 January 2016 to revalorise family allowances;
- Decree No. 2018/190 of 02 March 2018 amending and supplementing certain provisions of Decree No. 2011/408 of 09 December 2011 to organise the Government;
- Decree No. 2019/002 of 04 January 2019 to reshuffle the Government;
- Order No. 236/CAB/PR of 09 November 1978 laying down the procedure for granting civilian and military pensions, life annuities, death grants and death compensation;
- Ministerial Decision No. 1002854/DM/MINDEF/01 of 28 September 2010 on the invalidity of some personnel of the National Security and Defence Forces.

REQUIREMENT: Be the heir of an officer who died in active service and was entitled to an invalidity pension.

CONSTITUTION OF FILE:

- **Required documents:**
 - stamped application on *papier ministre* (ledger square paper) addressed to the Minister;
 - military service record;
 - certified photocopy of the spouse’s valid national identity card;
 - certificate of residence;
 - order granting invalidity pension or copy of the Ministerial Decision on the invalidity of some personnel of the Defence Forces;
 - copy(ies) of marriage certificate(s);
 - certificate of monogamy or polygamy;
 - certificate(s) of non-divorce, non-separation and non-remarriage;
 - certified photocopies of his/her children’s birth certificates (in the case of a recognised child, the page bearing the mention of recognition must be certified);
 - collective life certificate of all the children;
 - copy of death certificate of the service member (established at the council of the place of death);
 - original copies of school certificates of minor children for the current year;
 - payslip for the month in which the service member died;
 - null payslip of the deceased service member;
 - Unit Commander’s report on the circumstances of the death (where applicable);
 - photocopy of inheritance judgement;
 - photocopy of non-appeal certificate of the inheritance judgement;
 - certificate of individuality (where applicable);
 - Unit Commander’s report on the circumstances of the death (where applicable);
 - certificate of conformity of date of birth (where applicable);
 - invalidity pension payslip (where applicable).
- **Reference document:** Staff file

DEADLINE: Sixty (60) days

SIGNATORY OF THE INSTRUMENT: the President of the Republic

DELIVERY METHOD: Collection

QUALITY SUPERVISOR: the Director of Administrative and Regulatory Affairs

PROCESSING: cf. processing chain: **PROCEDURE No. 01/MINDEF/DAAR/PO/I
GRANTING A RETIREMENT PENSION**

**PROCEDURE No. 13/MINDEF/DAAR/PO/I
GRANTING ORPHAN'S TEMPORARY PENSION**

TITLE OF THE INSTRUMENT: Order granting orphan's temporary pension

INITIATOR OF THE PROCEDURE: Applicant

INITIATING ENTITY: Pensions Service

PLACE OF SUBMISSION OF FILE: Base unit

REFERENCE INSTRUMENTS:

- Law No. 67/LF/9 of 12 June 1967 on the general organisation of Defence;
- Law No. 80/12 of 14 July 1980 on general rules and regulations governing servicemen, together with all the amendments thereto;
- Decree No. 76/460 of 12 October 1976 to organise military pension schemes based on longevity of service and invalidity pensions, as amended by Decree No. 86/262 of 26 March 1986;
- Decree No. 78/488 of 09 November 1978 defining the terms and conditions for granting civilian and military pensions, life annuities, death grants and death compensation;
- Decree No. 80/257 of 15 July 1980 to lay down general rules and regulations governing the remuneration schemes applicable to military personnel of the Armed Forces, as amended by Decree No. 84/926 of 30 July 1984;
- Decree No. 82/341 of 09 August 1982 to lay down the conditions for granting death benefits;
- Decree No. 85/1092 of 02 August 1985 revalorising civilian and military pensions;
- Decree No. 2001/178 of 25 July 2001 on the general organisation of Defence and Central Staff;
- Decree No. 2001/188 of 25 July 2001 to lay down special rules and regulations governing the corps of Active Officers of the Defence Forces;
- Decree No. 2008/099 of 07 March 2008 to revalorise the basic monthly salaries of civilian and military personnel;
- Decree No. 2008/311 of 27 August 2008 granting an annuity bonus to some military personnel of the Defence Forces;
- Decree No. 2010/239 of 10 August 2010 amending the retirement of some Officers of the Defence Forces;
- Decree No. 2011/412 of 09 December 2011 to reorganise the Presidency of the Republic;
- Decree No. 2014/253 of 07 July 2014 to revalorise the basic monthly salaries of civilian and military personnel;
- Decree No. 2015/194 of 20 April 2015 granting an annuity bonus to some military personnel of the Defence Forces;
- Decree No. 2016/034 of 21 January 2016 to revalorise family allowances;
- Decree No. 2018/190 of 02 March 2018 amending and supplementing certain provisions of Decree No. 2011/408 of 09 December 2011 to organise the Government;
- Decree No. 2019/002 of 04 January 2019 to reshuffle the Government;
- Order No. 236/CAB/PR of 09 November 1978 laying down the procedure for granting civilian and military pensions, life annuities, death grants and death compensation.

REQUIREMENT: Be the minor orphan following the death of an unmarried officer parent.

CONSTITUTION OF FILE:

- **Required documents:**
 - stamped application on *papier ministre* (ledger square paper) addressed to the Minister;
 - copy of death certificate of the service member (established at the council of the place of death);
 - photocopy of guardianship judgement;
 - certified photocopy of non-appeal certificate;
 - guardian's certificate of residence;

- certified copy of guardian’s valid national identity card;
- certified photocopies of his/her children’s birth certificates (in the case of a recognised child, the page bearing the mention of recognition must be certified);
- collective life certificate of all the children;
- original copies of school certificates of minor children for the current year;
- payslip for the month in which the service member died;
- null payslip of the deceased service member;
- pensioner’s payslip;
- certificate of individuality (where applicable);
- certificate of celibacy of the deceased service member;
- military service record of the deceased service member;
- copies of marriage and death certificates of the spouse;
- photocopy of inheritance judgement;
- photocopy of non-appeal certificate of the inheritance judgement;
- certificate of conformity of date of birth (where applicable);
- decree granting a retirement pension (where applicable).

- **Reference document:** Staff file

DEADLINE: Sixty (60) days

SIGNATORY OF THE INSTRUMENT: the President of the Republic

DELIVERY METHOD: Collection

QUALITY SUPERVISOR: the Director of Administrative and Regulatory Affairs

PROCESSING: cf. processing chain: **PROCEDURE No. 01/MINDEF/DAAR/PO/I
GRANTING A RETIREMENT PENSION**

**PROCEDURE No. 14/MINDEF/DAAR/PO/I
GRANTING DEATH BENEFITS AND ORPHAN'S TEMPORARY PENSION**

TITLE OF THE INSTRUMENT: Order granting death benefits and orphan's temporary pension

INITIATOR OF THE PROCEDURE: Applicant

INITIATING ENTITY: Pensions Service

PLACE OF SUBMISSION OF FILE: Base unit

REFERENCE INSTRUMENTS:

- Law No. 67/LF/9 of 12 June 1967 on the general organisation of Defence;
- Law No. 80/12 of 14 July 1980 on general rules and regulations governing servicemen, together with all the amendments thereto;
- Decree No. 76/460 of 12 October 1976 to organise military pension schemes based on longevity of service and invalidity pensions, as amended by Decree No. 86/262 of 26 March 1986;
- Decree No. 78/488 of 09 November 1978 defining the terms and conditions for granting civilian and military pensions, life annuities, death grants and death compensation;
- Decree No. 80/257 of 15 July 1980 to lay down general rules and regulations governing the remuneration schemes applicable to military personnel of the Armed Forces, as amended by Decree No. 84/926 of 30 July 1984;
- Decree No. 82/341 of 09 August 1982 to lay down the conditions for granting death benefits;
- Decree No. 85/1092 of 02 August 1985 revalorising civilian and military pensions;
- Decree No. 2001/178 of 25 July 2001 on the general organisation of Defence and Central Staff;
- Decree No. 2001/188 of 25 July 2001 to lay down special rules and regulations governing the corps of Active Officers of the Defence Forces;
- Decree No. 2008/099 of 07 March 2008 to revalorise the basic monthly salaries of civilian and military personnel;
- Decree No. 2008/311 of 27 August 2008 granting an annuity bonus to some military personnel of the Defence Forces;
- Decree No. 2010/239 of 10 August 2010 amending the retirement of some Officers of the Defence Forces;
- Decree No. 2011/412 of 09 December 2011 to reorganise the Presidency of the Republic;
- Decree No. 2014/253 of 07 July 2014 to revalorise the basic monthly salaries of civilian and military personnel;
- Decree No. 2015/194 of 20 April 2015 granting an annuity bonus to some military personnel of the Defence Forces;
- Decree No. 2016/034 of 21 January 2016 to revalorise family allowances;
- Decree No. 2018/190 of 02 March 2018 amending and supplementing certain provisions of Decree No. 2011/408 of 09 December 2011 to organise the Government;
- Decree No. 2019/002 of 04 January 2019 to reshuffle the Government;
- Order No. 236/CAB/PR of 09 November 1978 laying down the procedure for granting civilian and military pensions, life annuities, death grants and death compensation.

REQUIREMENT: Be the minor orphan following the death of an unmarried officer parent.

CONSTITUTION OF FILE:

- **Required documents:**
 - stamped application on *papier ministre* (ledger square paper) addressed to the Minister;
 - copy of death certificate of the service member (established at the council of the place of death);

- photocopy of guardianship judgement;
- certified photocopy of non-appeal certificate;
- guardian's certificate of residence;
- certified copy of guardian's valid national identity card;
- certified photocopies of his/her children's birth certificates (in the case of a recognised child, the page bearing the mention of recognition must be certified);
- collective life certificate of all the children;
- original copies of school certificates of minor children for the current year;
- payslip for the month in which the service member died;
- null payslip of the deceased service member;
- certificate of individuality (where applicable);
- certificate of celibacy of the deceased service member;
- military service record of the deceased service member;
- copies of marriage and death certificates of the spouse;
- photocopy of inheritance judgement;
- photocopy of non-appeal certificate of the inheritance judgement;
- Unit Commander's report on the circumstances of the death (where applicable);
- certificate of conformity of date of birth (where applicable);
- copy of Ministerial Decision or Order on invalidity (where applicable);
- certificate of monogamy or polygamy;
- certificates of non-divorce, non-separation and non-remarriage.

- **Reference documents:** Staff file

DEADLINE: Sixty (60) days

SIGNATORY OF THE INSTRUMENT: the President of the Republic

DELIVERY METHOD: Collection

QUALITY SUPERVISOR: the Director of Administrative and Regulatory Affairs

PROCESSING: cf. processing chain: **PROCEDURE No. 01/MINDEF/DAAR/PO/I
GRANTING A RETIREMENT PENSION**

**PROCEDURE No. 15/MINDEF/DAAR/PO/I
GRANTING OF DEATH BENEFITS, TEMPORARY ORPHAN'S
PENSION AND REVERSION OF A LIFE-LONG INVALIDITY
PENSION**

TITLE OF THE INSTRUMENT: Order on the granting of death benefits, temporary orphan's pension and reversion of a life-long invalidity pension

INITIATOR OF THE PROCEDURE: Applicant

INITIATING ENTITY: Pensions Service

PLACE OF SUBMISSION OF FILE: Base unit

REFERENCE INSTRUMENTS:

- Law No. 67/LF/9 of 12 June 1967 on the general organisation of Defence;
- Law No. 80/12 of 14 July 1980 on general rules and regulations governing servicemen, together with all the amendments thereto;
- Decree No. 76/460 of 12 October 1976 to organise military pension schemes based on longevity of service and invalidity pensions, as amended by Decree No. 86/262 of 26 March 1986;
- Decree No. 78/488 of 09 November 1978 defining the terms and conditions for granting civilian and military pensions, life annuities, death grants and death compensation;
- Decree No. 80/257 of 15 July 1980 to lay down general rules and regulations governing the remuneration schemes applicable to military personnel of the Armed Forces, as amended by Decree No. 84/926 of 30 July 1984;
- Decree No. 82/341 of 09 August 1982 to lay down the conditions for granting death benefits;
- Decree No. 85/1092 of 02 August 1985 revalorising civilian and military pensions;
- Decree No. 2001/178 of 25 July 2001 on the general organisation of Defence and Central Staff;
- Decree No. 2001/188 of 25 July 2001 to lay down special rules and regulations governing the corps of Active Officers of the Defence Forces;
- Decree No. 2008/099 of 07 March 2008 to revalorise the basic monthly salaries of civilian and military personnel;
- Decree No. 2008/311 of 27 August 2008 granting an annuity bonus to some military personnel of the Defence Forces;
- Decree No. 2010/239 of 10 August 2010 amending the retirement of some Officers of the Defence Forces;
- Decree No. 2011/412 of 09 December 2011 to reorganise the Presidency of the Republic;
- Decree No. 2014/253 of 07 July 2014 to revalorise the basic monthly salaries of civilian and military personnel;
- Decree No. 2015/194 of 20 April 2015 granting an annuity bonus to some military personnel of the Defence Forces;
- Decree No. 2016/034 of 21 January 2016 to revalorise family allowances;
- Decree No. 2018/190 of 02 March 2018 amending and supplementing certain provisions of Decree No. 2011/408 of 09 December 2011 to organise the Government;
- Decree No. 2019/002 of 04 January 2019 to reshuffle the Government;
- Order No. 236/CAB/PR of 09 November 1978 laying down the procedure for granting civilian and military pensions, life annuities, death grants and death compensation;
- Ministerial Decision No. 1002854/DM/MINDEF/01 of 28 September 2010 on the invalidity of some personnel of the National Security and Defence Forces.

REQUIREMENT: Be the heir of an officer who died in active service and was entitled to an invalidity pension.

CONSTITUTION OF FILE:

- **Required documents:**
 - stamped application on *papier ministre* (ledger square paper) addressed to the Minister;
 - copy of death certificate of the service member (established at the council of the place of death);
 - photocopy of guardianship judgement;
 - certified photocopy of non-appeal certificate;
 - guardian's certificate of residence;
 - order granting invalidity pension or copy of the Ministerial Decision on the invalidity of some personnel of the Defence Forces;
 - certified copy of guardian's valid national identity card;
 - certified photocopies of his/her children's birth certificates (in the case of a recognised child, the page bearing the mention of recognition must be certified);
 - collective life certificate of all the children;
 - original copies of school certificates of minor children for the current year;
 - payslip for the month in which the service member died;
 - null payslip of the deceased service member;
 - certificate of individuality (where applicable);
 - certificate of celibacy of the deceased service member;
 - military service record of the deceased service member;
 - copies of marriage and death certificates of the spouse;
 - photocopy of inheritance judgement;
 - Unit Commander's report on the circumstances of the death (where applicable);
 - photocopy of non-appeal certificate of the inheritance judgement;
 - Unit Commander's report on the circumstances of the death (where applicable);
 - certificate of conformity of date of birth (where applicable);
 - invalidity pension payslip (where applicable);
 - decree granting a retirement pension (where applicable);
 - certificate of monogamy or polygamy;
 - certificates of non-divorce, non-separation and non-remarriage.
- **Reference document:** Staff file

DEADLINE: Sixty (60) days

SIGNATORY OF THE INSTRUMENT: the President of the Republic

DELIVERY METHOD: Collection

QUALITY SUPERVISOR: the Director of Administrative and Regulatory Affairs

PROCESSING: cf. processing chain: **PROCEDURE No. 01/MINDEF/DAAR/PO/I
GRANTING A RETIREMENT PENSION**

**PROCEDURE No. 16/MINDEF/DAAR/PO/I
GRANTING A REVERSIONARY PENSION**

TITLE OF THE INSTRUMENT: Order granting a reversionary pension

INITIATOR OF THE PROCEDURE: Applicant

INITIATING ENTITY: Pensions Service

PLACE OF SUBMISSION OF FILE: Base unit

REFERENCE INSTRUMENTS:

- Law No. 67/LF/9 of 12 June 1967 on the general organisation of Defence;
- Law No. 80/12 of 14 July 1980 on general rules and regulations governing servicemen, together with all the amendments thereto;
- Decree No. 76/460 of 12 October 1976 to organise military pension schemes based on longevity of service and invalidity pensions, as amended by Decree No. 86/262 of 26 March 1986;
- Decree No. 78/488 of 09 November 1978 defining the terms and conditions for granting civilian and military pensions, life annuities, death grants and death compensation;
- Decree No. 80/257 of 15 July 1980 to lay down general rules and regulations governing the remuneration schemes applicable to military personnel of the Armed Forces, as amended by Decree No. 84/926 of 30 July 1984;
- Decree No. 82/341 of 09 August 1982 to lay down the conditions for granting death benefits;
- Decree No. 85/1092 of 02 August 1985 revalorising civilian and military pensions;
- Decree No. 2001/178 of 25 July 2001 on the general organisation of Defence and Central Staff;
- Decree No. 2001/188 of 25 July 2001 to lay down special rules and regulations governing the corps of Active Officers of the Defence Forces;
- Decree No. 2008/099 of 07 March 2008 to revalorise the basic monthly salaries of civilian and military personnel;
- Decree No. 2008/311 of 27 August 2008 granting an annuity bonus to some military personnel of the Defence Forces;
- Decree No. 2010/239 of 10 August 2010 amending the retirement of some Officers of the Defence Forces;
- Decree No. 2011/412 of 09 December 2011 to reorganise the Presidency of the Republic;
- Decree No. 2014/253 of 07 July 2014 to revalorise the basic monthly salaries of civilian and military personnel;
- Decree No. 2015/194 of 20 April 2015 granting an annuity bonus to some military personnel of the Defence Forces;
- Decree No. 2016/034 of 21 January 2016 to revalorise family allowances;
- Decree No. 2018/190 of 02 March 2018 amending and supplementing certain provisions of Decree No. 2011/408 of 09 December 2011 to organise the Government;
- Decree No. 2019/002 of 04 January 2019 to reshuffle the Government;
- Order No. 236/CAB/PR of 09 November 1978 laying down the procedure for granting civilian and military pensions, life annuities, death grants and death compensation;
- Ministerial Decision No. 1002854/DM/MINDEF/01 of 28 September 2010 on the invalidity of some personnel of the National Security and Defence Forces.

REQUIREMENT: Be the widower/widow(s) of a deceased pensioner officer.

CONSTITUTION OF FILE:

- **Required documents:**
 - stamped application on papier ministre (ledger square paper) addressed to the Minister;
 - certified copy of the spouse's valid national identity card;
 - certificate of residence;
 - copy(ies) of marriage certificate(s);
 - certificate of monogamy or polygamy;
 - certificate(s) of non-divorce, non-separation and non-remarriage;
 - certificates of non-remarriage and non-cohabitation;
 - certified photocopies of his/her children's birth certificates (in the case of a recognised child, the page bearing the mention of recognition must be certified);
 - collective life certificate of all the children;
 - copy of death certificate of the service member (established at the council of the place of death);
 - original copies of school certificates of minor children for the current year;
 - payslip for the month in which the service member died;
 - null payslip of the deceased service member;
 - photocopy of inheritance judgement;
 - photocopy of non-appeal certificate of the inheritance judgement;
 - certificate of individuality (where applicable);
 - certificate of conformity of date of birth (where applicable);
 - decree granting a retirement pension (where applicable).

- **Reference document:** Staff file

DEADLINE: Sixty (60) days

SIGNATORY OF THE INSTRUMENT: the President of the Republic

DELIVERY METHOD: Collection

QUALITY SUPERVISOR: the Director of Administrative and Regulatory Affairs

PROCESSING: cf. processing chain: **PROCEDURE No. 01/MINDEF/DAAR/PO/I
GRANTING A RETIREMENT PENSION**

PROCEDURE No. 17/MINDEF/DAAR/PO/I
GRANTING AND REVERSION OF A LIFE-LONG INVALIDITY PENSION

TITLE OF THE INSTRUMENT: Order on the granting and reversion of a life-long invalidity pension

INITIATOR OF THE PROCEDURE: Applicant

INITIATING ENTITY: Pensions Service

PLACE OF SUBMISSION OF FILE: Base unit

REFERENCE INSTRUMENTS:

- Law No. 67/LF/9 of 12 June 1967 on the general organisation of Defence;
- Law No. 80/12 of 14 July 1980 on general rules and regulations governing servicemen, together with all the amendments thereto;
- Decree No. 76/460 of 12 October 1976 to organise military pension schemes based on longevity of service and invalidity pensions, as amended by Decree No. 86/262 of 26 March 1986;
- Decree No. 78/488 of 09 November 1978 defining the terms and conditions for granting civilian and military pensions, life annuities, death grants and death compensation;
- Decree No. 80/257 of 15 July 1980 to lay down general rules and regulations governing the remuneration schemes applicable to military personnel of the Armed Forces, as amended by Decree No. 84/926 of 30 July 1984;
- Decree No. 82/341 of 09 August 1982 to lay down the conditions for granting death benefits;
- Decree No. 85/1092 of 02 August 1985 revalorising civilian and military pensions;
- Decree No. 2001/178 of 25 July 2001 on the general organisation of Defence and Central Staff;
- Decree No. 2001/188 of 25 July 2001 to lay down special rules and regulations governing the corps of Active Officers of the Defence Forces;
- Decree No. 2008/099 of 07 March 2008 to revalorise the basic monthly salaries of civilian and military personnel;
- Decree No. 2008/311 of 27 August 2008 granting an annuity bonus to some military personnel of the Defence Forces;
- Decree No. 2010/239 of 10 August 2010 amending the retirement of some Officers of the Defence Forces;
- Decree No. 2011/412 of 09 December 2011 to reorganise the Presidency of the Republic;
- Decree No. 2014/253 of 07 July 2014 to revalorise the basic monthly salaries of civilian and military personnel;
- Decree No. 2015/194 of 20 April 2015 granting an annuity bonus to some military personnel of the Defence Forces;
- Decree No. 2016/034 of 21 January 2016 to revalorise family allowances;
- Decree No. 2018/190 of 02 March 2018 amending and supplementing certain provisions of Decree No. 2011/408 of 09 December 2011 to organise the Government;
- Decree No. 2019/002 of 04 January 2019 to reshuffle the Government;
- Order No. 236/CAB/PR of 09 November 1978 laying down the procedure for granting civilian and military pensions, life annuities, death grants and death compensation;
- Ministerial Decision No. 1002854/DM/MINDEF/01 of 28 September 2010 on the invalidity of some personnel of the National Security and Defence Forces.

REQUIREMENT: Be the widower/widow(s) of a deceased officer who was entitled to an invalidity pension and benefitted from a reversionary pension.

CONSTITUTION OF FILE:

- **Required documents:**
 - stamped application on *papier ministre* (ledger square paper) addressed to the Minister;
 - certified copy of the spouse's valid national identity card;
 - order granting invalidity pension or copy of the Ministerial Decision on the invalidity of some personnel of the Defence Forces;
 - decree granting a retirement pension;
 - certificate of residence;
 - copy(ies) of marriage certificate(s);
 - certificate of monogamy or polygamy;
 - certificate(s) of non-divorce, non-separation and non-remarriage;
 - certificates of non-remarriage and non-cohabitation;
 - certified photocopies of his/her children's birth certificates (in the case of a recognised child, the page bearing the mention of recognition must be certified);
 - collective life certificate of all the children;
 - copy of death certificate of the service member (established at the council of the place of death);
 - original copies of school certificates of minor children for the current year;
 - payslip for the month in which the service member died;
 - null payslip of the deceased service member;
 - photocopy of inheritance judgement;
 - photocopy of non-appeal certificate of the inheritance judgement;
 - certificate of individuality (where applicable);
 - certificate of conformity of date of birth (where applicable).
- **Reference document:** Staff file

DEADLINE: Sixty (60) days

SIGNATORY OF THE INSTRUMENT: the President of the Republic

DELIVERY METHOD: Collection

QUALITY SUPERVISOR: the Director of Administrative and Regulatory Affairs

PROCESSING: cf. processing chain: **PROCEDURE No. 01/MINDEF/DAAR/PO/I
GRANTING A RETIREMENT PENSION**

PROCEDURE No. 18/MINDEF/DAAR/PO/I
GRANTING DEATH BENEFITS AND SURVIVOR'S PENSION

TITLE OF THE INSTRUMENT: Order granting death benefits and survivor's pension

INITIATOR OF THE PROCEDURE: Applicant

INITIATING ENTITY: Pensions Service

PLACE OF SUBMISSION OF FILE: Base unit

REFERENCE INSTRUMENTS:

- Law No. 67/LF/9 of 12 June 1967 on the general organisation of Defence;
- Law No. 80/12 of 14 July 1980 on general rules and regulations governing servicemen, together with all the amendments thereto;
- Decree No. 76/460 of 12 October 1976 to organise military pension schemes based on longevity of service and invalidity pensions, as amended by Decree No. 86/262 of 26 March 1986;
- Decree No. 78/488 of 09 November 1978 defining the terms and conditions for granting civilian and military pensions, life annuities, death grants and death compensation;
- Decree No. 80/257 of 15 July 1980 to lay down general rules and regulations governing the remuneration schemes applicable to military personnel of the Armed Forces, as amended by Decree No. 84/926 of 30 July 1984;
- Decree No. 82/341 of 09 August 1982 to lay down the conditions for granting death benefits;
- Decree No. 85/1092 of 02 August 1985 revalorising civilian and military pensions;
- Decree No. 2001/178 of 25 July 2001 on the general organisation of Defence and Central Staff;
- Decree No. 2001/188 of 25 July 2001 to lay down special rules and regulations governing the corps of Active Officers of the Defence Forces;
- Decree No. 2008/099 of 07 March 2008 to revalorise the basic monthly salaries of civilian and military personnel;
- Decree No. 2008/311 of 27 August 2008 granting an annuity bonus to some military personnel of the Defence Forces;
- Decree No. 2010/239 of 10 August 2010 amending the retirement of some Officers of the Defence Forces;
- Decree No. 2011/412 of 09 December 2011 to reorganise the Presidency of the Republic;
- Decree No. 2014/253 of 07 July 2014 to revalorise the basic monthly salaries of civilian and military personnel;
- Decree No. 2015/194 of 20 April 2015 granting an annuity bonus to some military personnel of the Defence Forces;
- Decree No. 2016/034 of 21 January 2016 to revalorise family allowances;
- Decree No. 2018/190 of 02 March 2018 amending and supplementing certain provisions of Decree No. 2011/408 of 09 December 2011 to organise the Government;
- Decree No. 2019/002 of 04 January 2019 to reshuffle the Government;
- Order No. 236/CAB/PR of 09 November 1978 laying down the procedure for granting civilian and military pensions, life annuities, death grants and death compensation.

REQUIREMENTS:

- be a father (above 60 years) or mother (above 55 years) of an unmarried and childless officer who died in active service;
- not be subject to personal income tax.

CONSTITUTION OF FILE:

- **Required documents:**
 - stamped application on *papier ministre* (ledger square paper) addressed to the Minister;
 - copy of death certificate of the service member (established at the council of the place of death);
 - certified photocopy of the survivor's valid national identity card (father above 60 years or mother above 55 years or any disabled or invalid parent regardless of age);
 - military service record of the deceased service member;
 - photocopy of the inheritance judgement;
 - certificate of celibacy of the deceased;
 - certified copy of non-appeal certificate of the inheritance judgement;
 - certificate of residence of the applicant parent;
 - certified copy of birth certificate of the deceased;
 - payslip for the month in which the service member died;
 - null payslip;
 - certificate of unemployment;
 - Unit Commander's report on the circumstances of the death (where applicable);
 - individual life certificate of the applicant parent;
 - certificate of individuality (where applicable);
 - certificate of conformity of date of birth (where applicable).
- **Reference document:** Staff file

DEADLINE: Sixty (60) days

SIGNATORY OF THE INSTRUMENT: the President of the Republic

DELIVERY METHOD: Collection

QUALITY SUPERVISOR: the Director of Administrative and Regulatory Affairs

PROCESSING: cf. processing chain: **PROCEDURE No. 01/MINDEF/DAAR/PO/I
GRANTING A RETIREMENT PENSION**

**PROCEDURE No. 19/MINDEF/DAAR/PO/I
REIMBURSEMENT OF PENSION DEDUCTIONS**

TITLE OF THE INSTRUMENT: Order on reimbursement of pension deductions

INITIATOR OF THE PROCEDURE: Applicant

INITIATING ENTITY: Pensions Service

PLACE OF SUBMISSION OF FILE: Base unit

REFERENCE INSTRUMENTS:

- Law No. 67/LF/9 of 12 June 1967 on the general organisation of Defence;
- Law No. 80/12 of 14 July 1980 on general rules and regulations governing servicemen, together with all the amendments thereto;
- Decree No. 76/460 of 12 October 1976 to organise military pension schemes based on longevity of service and invalidity pensions, as amended by Decree No. 86/262 of 26 March 1986;
- Decree No. 78/488 of 09 November 1978 defining the terms and conditions for granting civilian and military pensions, life annuities, death grants and death compensation;
- Decree No. 80/257 of 15 July 1980 to lay down general rules and regulations governing the remuneration schemes applicable to military personnel of the Armed Forces, as amended by Decree No. 84/926 of 30 July 1984;
- Decree No. 82/341 of 09 August 1982 to lay down the conditions for granting death benefits;
- Decree No. 85/1092 of 02 August 1985 revalorising civilian and military pensions;
- Decree No. 2001/178 of 25 July 2001 on the general organisation of Defence and Central Staff;
- Decree No. 2001/188 of 25 July 2001 to lay down special rules and regulations governing the corps of Active Officers of the Defence Forces;
- Decree No. 2008/099 of 07 March 2008 to revalorise the basic monthly salaries of civilian and military personnel;
- Decree No. 2008/311 of 27 August 2008 granting an annuity bonus to some military personnel of the Defence Forces;
- Decree No. 2010/239 of 10 August 2010 amending the retirement of some Officers of the Defence Forces;
- Decree No. 2011/412 of 09 December 2011 to reorganise the Presidency of the Republic;
- Decree No. 2014/253 of 07 July 2014 to revalorise the basic monthly salaries of civilian and military personnel;
- Decree No. 2015/194 of 20 April 2015 granting an annuity bonus to some military personnel of the Defence Forces;
- Decree No. 2016/034 of 21 January 2016 to revalorise family allowances;
- Decree No. 2018/190 of 02 March 2018 amending and supplementing certain provisions of Decree No. 2011/408 of 09 December 2011 to organise the Government;
- Decree No. 2019/002 of 04 January 2019 to reshuffle the Government;
- Order No. 236/CAB/PR of 09 November 1978 laying down the procedure for granting civilian and military pensions, life annuities, death grants and death compensation.

REQUIREMENT: Be an officer dismissed/retired before having completed at least 15 years of service.

CONSTITUTION OF FILE:

- **Required documents:**
 - stamped application on *papier ministre* (ledger square paper) addressed to the Minister;
 - recent payslip;
 - certified copy of valid national identity card;
 - military service record of the deceased service member;
 - ministerial decision to **strike off staff**;

- certificate of residence;
- certificate of individuality (where applicable);
- certificate of conformity of date of birth (where applicable).

- **Reference documents:** N/A

DEADLINE: Sixty (60) days

SIGNATORY OF THE INSTRUMENT: the President of the Republic

DELIVERY METHOD: Collection

QUALITY SUPERVISOR: the Director of Administrative and Regulatory Affairs

PROCESSING: cf. processing chain: **PROCEDURE No. 01/MINDEF/DAAR/PO/I
GRANTING A RETIREMENT PENSION**

**PROCEDURE No. 20/MINDEF/DAAR/PO/I
GRANTING DEATH BENEFITS**

TITLE OF THE INSTRUMENT: Order granting death benefits

INITIATOR OF THE PROCEDURE: Applicant

INITIATING ENTITY: Pensions Service

PLACE OF SUBMISSION OF FILE: Base unit

REFERENCE INSTRUMENTS:

- Law No. 67/LF/9 of 12 June 1967 on the general organisation of Defence;
- Law No. 80/12 of 14 July 1980 on general rules and regulations governing servicemen, together with all the amendments thereto;
- Decree No. 76/460 of 12 October 1976 to organise military pension schemes based on longevity of service and invalidity pensions, as amended by Decree No. 86/262 of 26 March 1986;
- Decree No. 78/488 of 09 November 1978 defining the terms and conditions for granting civilian and military pensions, life annuities, death grants and death compensation;
- Decree No. 80/257 of 15 July 1980 to lay down general rules and regulations governing the remuneration schemes applicable to military personnel of the Armed Forces, as amended by Decree No. 84/926 of 30 July 1984;
- Decree No. 82/341 of 09 August 1982 to lay down the conditions for granting death benefits;
- Decree No. 85/1092 of 02 August 1985 revalorising civilian and military pensions;
- Decree No. 2001/178 of 25 July 2001 on the general organisation of Defence and Central Staff;
- Decree No. 2001/188 of 25 July 2001 to lay down special rules and regulations governing the corps of Active Officers of the Defence Forces;
- Decree No. 2008/099 of 07 March 2008 to revalorise the basic monthly salaries of civilian and military personnel;
- Decree No. 2008/311 of 27 August 2008 granting an annuity bonus to some military personnel of the Defence Forces;
- Decree No. 2010/239 of 10 August 2010 amending the retirement of some Officers of the Defence Forces;
- Decree No. 2011/412 of 09 December 2011 to reorganise the Presidency of the Republic;
- Decree No. 2014/253 of 07 July 2014 to revalorise the basic monthly salaries of civilian and military personnel;
- Decree No. 2015/194 of 20 April 2015 granting an annuity bonus to some military personnel of the Defence Forces;
- Decree No. 2016/034 of 21 January 2016 to revalorise family allowances;
- Decree No. 2018/190 of 02 March 2018 amending and supplementing certain provisions of Decree No. 2011/408 of 09 December 2011 to organise the Government;
- Decree No. 2019/002 of 04 January 2019 to reshuffle the Government;
- Order No. 236/CAB/PR of 09 November 1978 laying down the procedure for granting civilian and military pensions, life annuities, death grants and death compensation.

REQUIREMENT: Be the benefactor/heir of an officer who died in active service.

CONSTITUTION OF FILE:

- **Required documents:**
 - stamped application on *papier ministre* (ledger square paper) addressed to the Minister;
 - recent payslip;
 - certified copy of valid national identity card;
 - military service record of the deceased service member;

- inheritance judgement;
 - certificate of residence;
 - **medical certificate indicating the nature of death;**
 - Unit Commander's report on the circumstances of the death (where applicable);
 - certificate of individuality (where applicable);
 - certificate of conformity of date of birth (where applicable).
- **Reference documents:** N/A

DEADLINE: Sixty (60) days

SIGNATORY OF THE INSTRUMENT: the President of the Republic

DELIVERY METHOD: Collection

QUALITY SUPERVISOR: the Director of Administrative and Regulatory Affairs

PROCESSING: cf. processing chain: **PROCEDURE No. 01/MINDEF/DAAR/PO/I**
GRANTING A RETIREMENT PENSION

NON-COMMISSIONED PERSONNEL PENSION

**PROCEDURE No. 21/MINDEF/DAAR/PO/I
GRANTING TECHNICAL ALLOWANCE**

TITLE OF THE INSTRUMENT: Order granting technical allowance

INITIATOR OF THE PROCEDURE: Applicant

INITIATING ENTITY: Studies and Regulatory Service

PLACE OF SUBMISSION OF FILE: Base unit

REFERENCE INSTRUMENTS:

- Law No. 67/LF/9 of 12 June 1967 on the general organisation of Defence;
- Law No. 71/LF/3 of 04 June 1971 on rules and regulations governing officers;
- Law No. 80/12 of 14 July 1980 on general rules and regulations governing servicemen, together with all the amendments thereto;
- Decree No. 76/460 of 12 October 1976 to organise military pension schemes based on longevity of service and invalidity pensions, as amended by Decree No. 86/262 of 26 March 1986;
- Decree No. 71/DF of 29 June 1971 fixing the rates and lists of securities, certificates or patents entitled to the technical allowance established by Decree No. 68/DF/270 of 15 July 1968 on the general regulations on remuneration schemes applicable to military personnel of the Armed Forces.
- Decree No. 80/257 of 15 July 1980 to lay down general rules and regulations governing the remuneration schemes applicable to military personnel of the Armed Forces, as amended by Decree No. 84/926 of 30 July 1984;
- Decree No. 2001/178 of 25 July 2001 on the general organisation of Defence and Central Staff;
- Decree No. 2001/188 of 25 July 2001 to lay down special rules and regulations governing the corps of Active Officers of the Defence Forces;
- Decree No. 2018/190 of 02 March 2018 amending and supplementing certain provisions of Decree No. 2011/408 of 09 December 2011 to organise the Government.

REQUIREMENTS:

- be an officer with a technical allowance qualification/certificate;;
- have an authorisation for training issued by the Minister of Defence, for military personnel in active service.

CONSTITUTION OF FILE:

- **Required documents:**
 - stamped application on *papier ministre* (ledger square paper) addressed to the Minister;
 - certified copy of certificate;
 - copy of authorisation instrument issued by the Minister of Defence, where applicable.
- **Reference document:** Staff file









DEADLINE: Sixty (60) days

SIGNATORY OF THE INSTRUMENT: the Minister

DELIVERY METHOD: Collection

QUALITY SUPERVISOR: the Director of Administrative and Regulatory Affairs

PROCESSING

DEPARTMENT OF ADMINISTRATIVE AND REGULATORY AFFAIRS	PROCEDURE No. 21/MINDEF/DAAR/PO/I GRANTING TECHNICAL ALLOWANCE		Procedure start date: 2023	
			Procedure version:	
			Deadline	Page
<i>Intervening parties</i>	<i>Stages</i>		<i>Handling rules</i>	
				R1: Check file's compliance
 <div style="border: 1px solid black; padding: 2px; display: inline-block;">Applicant</div>	<div style="border: 1px solid black; padding: 5px; width: fit-content; margin: 0 auto;">Submits the file</div>			R2: Check the authenticity of information provided
 <div style="border: 1px solid black; padding: 2px; display: inline-block;">Base unit</div>	<div style="border: 1px solid black; padding: 5px; width: fit-content; margin: 0 auto;"> <ul style="list-style-type: none"> - Receives the file - Registers the file - Forwards the file to the Department of Administrative and Regulatory Affairs </div>			R3: Ensure that the applicant is eligible
 <div style="border: 1px solid black; padding: 2px; display: inline-block;">DAAR</div>	<div style="border: 1px solid black; padding: 5px; width: fit-content; margin: 0 auto;"> <ul style="list-style-type: none"> - Receives the file - Assigns the file to the CSER </div>			R4: Ensure procedure consistency
 <div style="border: 1px solid black; padding: 2px; display: inline-block;">CSER</div>	<div style="border: 1px solid black; padding: 5px; width: fit-content; margin: 0 auto;"> <ul style="list-style-type: none"> - Receives the file - Reviews - Assigns the file to the Bureau Head of Pensions Service </div>			
 <div style="border: 1px solid black; padding: 2px; display: inline-block;">CBLR</div>	<div style="border: 1px solid black; padding: 5px; width: fit-content; margin: 0 auto;"> <ul style="list-style-type: none"> - Receives the file - Initiates the draft instrument - Forwards the file to the CSER </div>			
 <div style="border: 1px solid black; padding: 2px; display: inline-block;">CSER</div>	<div style="border: 1px solid black; padding: 5px; width: fit-content; margin: 0 auto;"> <ul style="list-style-type: none"> - Receives the file - Initials the slip and the draft instrument - Initiates the forwarding slip to the CFI </div>			
 <div style="border: 1px solid black; padding: 2px; display: inline-block;">DAAR</div>	<div style="border: 1px solid black; padding: 5px; width: fit-content; margin: 0 auto;"> <ul style="list-style-type: none"> - Forwards the file to the Department of Administrative and Regulatory Affairs - Signs the forwarding slip to the CF - Forwards the file to the CF </div>			
FINANCIAL CONTROLLER				
 <div style="border: 1px solid black; padding: 2px; display: inline-block;">Financial Controller</div>	<div style="border: 1px solid black; padding: 5px; width: fit-content; margin: 0 auto;"> <ul style="list-style-type: none"> - Receives the file - Reviews - Initials - Forwards the file to the Department of Administrative and Regulatory Affairs </div>			
MINDEF				

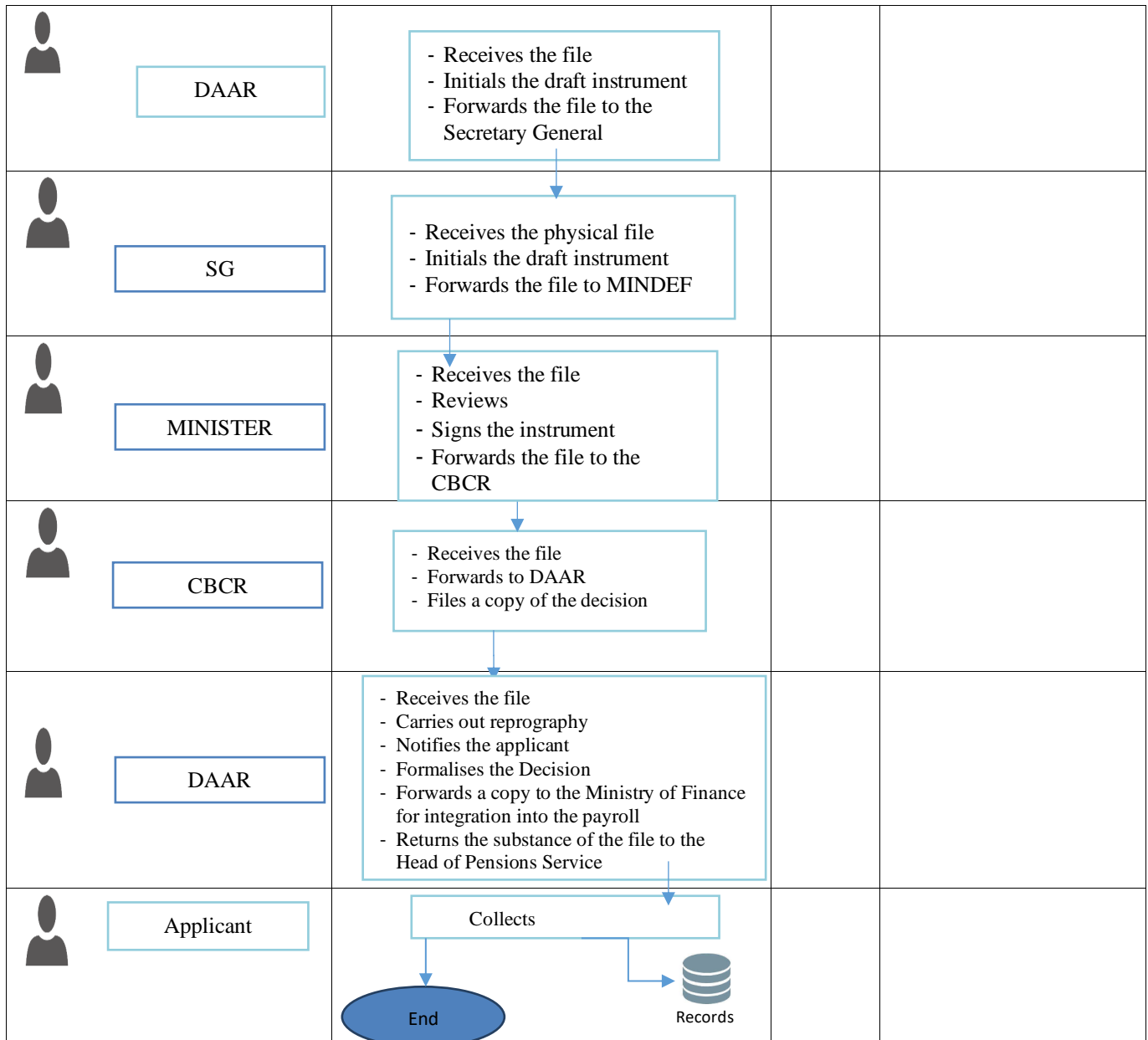

**PROCEDURE No. 22/MINDEF/DAAR/PO/I
GRANTING VEHICLE MAINTENANCE ALLOWANCE**

TITLE OF THE INSTRUMENT: Decision granting vehicle maintenance allowance
INITIATOR OF THE PROCEDURE: Applicant

INITIATING ENTITY: Studies and Regulatory Service

PLACE OF SUBMISSION OF FILE: Base unit

REFERENCE INSTRUMENTS:

- Law No. 67/LF/9 of 12 June 1967 on the general organisation of Defence;
- Law No. 80/12 of 14 July 1980 on general rules and regulations governing servicemen, together with all the amendments thereto;
- Decree No. 76/460 of 12 October 1976 to organise military pension schemes based on longevity of service and invalidity pensions, as amended by Decree No. 86/262 of 26 March 1986;
- Decree No. 80/257 of 15 July 1980 to lay down general rules and regulations governing the remuneration schemes applicable to military personnel of the Armed Forces, as amended by Decree No. 84/926 of 30 July 1984;
- Decree No. 87/1142 of 20 August 1987 regulating the use of military vehicles of the commercial range, the granting of advance to military personnel and agents of the Ministry of Defence for the acquisition of personal vehicles, and the conditions for participation of the State in the expenses of maintenance of the vehicles of some service personnel;
- Decree No. 2001/188 of 25 July 2001 to lay down special rules and regulations governing the corps of Active Officers of the Defence Forces;
- Decree No. 2018/190 of 02 March 2018 amending and supplementing certain provisions of Decree No. 2011/408 of 09 December 2011 to organise the Government.

PLACE OF SUBMISSION OF FILE: SED/CGN and/or Elementary Unit Mail Service

REQUIREMENT: Be an officer using his/her personal vehicle for service purposes.

CONSTITUTION OF FILE:

• **Required documents:**

- stamped application on *papier ministre* (ledger square paper) addressed to the Minister;
- copy of vehicle registration document;
- payslip;
- confirmatory note from the Service Head attesting that the owner of the vehicle uses it for service purposes.

• **Reference document:** Staff file

DEADLINE: Sixty (60) days

SIGNATORY OF THE INSTRUMENT: the Minister

DELIVERY METHOD: Collection

QUALITY SUPERVISOR: the Director of Administrative and Regulatory Affairs

PROCESSING: cf. processing chain: **PROCEDURE No. 21/ MINDEF/ DAAR/PO/I
GRANTING TECHNICAL ALLOWANCE**

NON-COMMISSIONED SERVICE PERSONNEL PENSION

NOTA BENE: In principle, placing a non-commissioned officer on retirement is by Order of the Minister Delegate, be it individual or collective. This instrument is initiated by the Department of Human Resource. However, in some specific cases, a single instrument puts the non-commissioned officer on retirement and grants him/her the retirement pension and accompanying advantages at the same time. This is the case for example when the non-commissioned officer is released from military obligations (**Final Reform No. 1**), after a session of the Reform Commission.

*PROCEDURE No. 23/MINDEF/DAAR/PNO/
GRANTING A RETIREMENT PENSION*

TITLE OF THE INSTRUMENT: Order granting a retirement pension

INITIATOR OF THE PROCEDURE: Applicant

INITIATING ENTITY: Pensions Service

PLACE OF SUBMISSION OF FILE: Base unit

REFERENCE INSTRUMENTS:

- Law No. 67/LF/9 of 12 June 1967 on the general organisation of Defence;
- Law No. 80/12 of 14 July 1980 on general rules and regulations governing servicemen, together with all the amendments thereto;
- Decree No. 76/460 of 12 October 1976 to organise military pension schemes based on longevity of service and invalidity pensions, as amended by Decree No. 86/262 of 26 March 1986;
- Decree No. 72/DF/108 of 26 February 1972 amending Decree No. 70/DF/318 of 23 June 1970 amending Decree No. 69/DF/228 of 09 June 1969 on the remuneration elements of civilian and military personnel of the Federal Public Service;
- Decree No. 78/488 of 09 November 1978 defining the terms and conditions for granting civilian and military pensions, life annuities, death grants and death compensation;
- Decree No. 80/257 of 15 July 1980 to lay down general rules and regulations governing the remuneration schemes applicable to military personnel of the Armed Forces, as amended by Decree No. 84/926 of 30 July 1984;
- Decree No. 82/341 of 09 August 1982 to lay down the conditions for granting death benefits;
- Decree No. 85/1092 of 02 August 1985 revalorising civilian and military pensions;
- Decree No. 2001/178 of 25 July 2001 on the general organisation of Defence and Central Staff;
- Decree No. 2001/219 of 06 August 2001 to lay down special rules and regulations governing non-commissioned officers of the Defence Forces;
- Decree No. 2004/056 of 23 March 2004 to organise the mobilisable reserve of non-commissioned officers of the Defence Forces;
- Decree No. 2008/099 of 07 March 2008 to revalorise the basic monthly salaries of civilian and military personnel;
- Decree No. 2008/311 of 27 August 2008 granting an annuity bonus to some military personnel of the Defence Forces;
- Decree No. 2010/382 of 22 December 2010 to amend Decree No. 2001/219 of 06 August 2001 to lay down special rules and regulations governing non-commissioned officers of the Defence Forces;
- Decree No. 2011/412 of 09 December 2011 to reorganise the Presidency of the Republic;
- Decree No. 2014/253 of 07 July 2014 to revalorise the basic monthly salaries of civilian and military personnel;
- Decree No. 2015/194 of 20 April 2015 granting an annuity bonus to some military personnel of the Defence Forces;
- Decree No. 2016/034 of 21 January 2016 to revalorise family allowances;
- Decree No. 2018/190 of 02 March 2018 amending and supplementing certain provisions of Decree No. 2011/408 of 09 December 2011 to organise the Government;
- Decree No. 2019/002 of 04 January 2019 to reshuffle the Government;
- Order No. 236/CAB/PR of 09 November 1978 laying down the procedure for granting civilian and military pensions, life annuities, death grants and death compensation.

REQUIREMENT: Be a retired non-commissioned service member with at least 15 years of service.

CONSTITUTION OF FILE:

• **Required documents:**

- stamped application on *papier ministre* (ledger square paper) addressed to the Minister;

- retirement order;
- military service record;
- certificate of residence;
- certified copy of valid national identity card of the applicant;
- certified copy of birth certificate;
- certified photocopies of his/her children's birth certificates (in the case of a recognised child, the page bearing the mention of recognition must be certified);
- collective life certificate of all the children;
- original copies of school certificates of minor children for the current year;
- original copy of bank account certificate;
- last payslip with salary;
- copy of marriage certificate or certificate of celibacy;
- photocopy of divorce judgement and certificate of non-appeal or death certificate of the spouse (where applicable);
- certificate of individuality (where applicable);
- certificate of conformity of date of birth (where applicable).

- **Reference documents:** Staff file

DEADLINE: Sixty (60) days

SIGNATORY OF THE INSTRUMENT: the Minister

DELIVERY METHOD: Collection

QUALITY SUPERVISOR: the Director of Administrative and Regulatory Affairs

PROCESSING

DEPARTMENT OF ADMINISTRATIVE AND REGULATORY AFFAIRS REGLEMENTAIRES	PROCEDURE No. 23/MINDEF/DAAR/PNO/I <u>GRANTING A RETIREMENT PENSION</u>	Procedure start date: 2023	
		Procedure version:	
		Deadline	Page
<i>Intervening parties</i>	<i>Stages</i>		<i>Handling rules</i>
<p>Applicant</p> <p>Base unit</p> <p>DAAR</p> <p>CSP</p> <p>CBPS</p> <p>CSP</p> <p>DAAR</p>	<p>Beginning</p> <ul style="list-style-type: none"> - Submits the file - Receives the file - Registers the file - Forwards the file to the Department of Administrative and Regulatory Affairs - Receives the file - Assigns the file to the Head of Pensions Service - Receives the file - Reviews - Assigns the file to the Bureau Head of Pensions Service - Receives the file - Reviews - Orders a service status report - Initiates the draft instrument - Forwards the file to the Head of Personnel Service - Receives the file - Initials the slip - Initiates the forwarding slip to the CFI - Forwards the file to the Department of Administrative and Regulatory Affairs - Receives the file - Signs the forwarding slip to the CF - Forwards the file to the CF 		<p>R1: Check file's compliance</p> <p>R2: Check the authenticity of information provided</p> <p>R3: Ensure that the applicant is eligible</p> <p>R4: Ensure procedure consistency</p>
FINANCIAL CONTROLLER			
<p>CF</p>	<ul style="list-style-type: none"> - Receives the file - Reviews - Initials - Forwards the file to the Department of Administrative and Regulatory Affairs 		

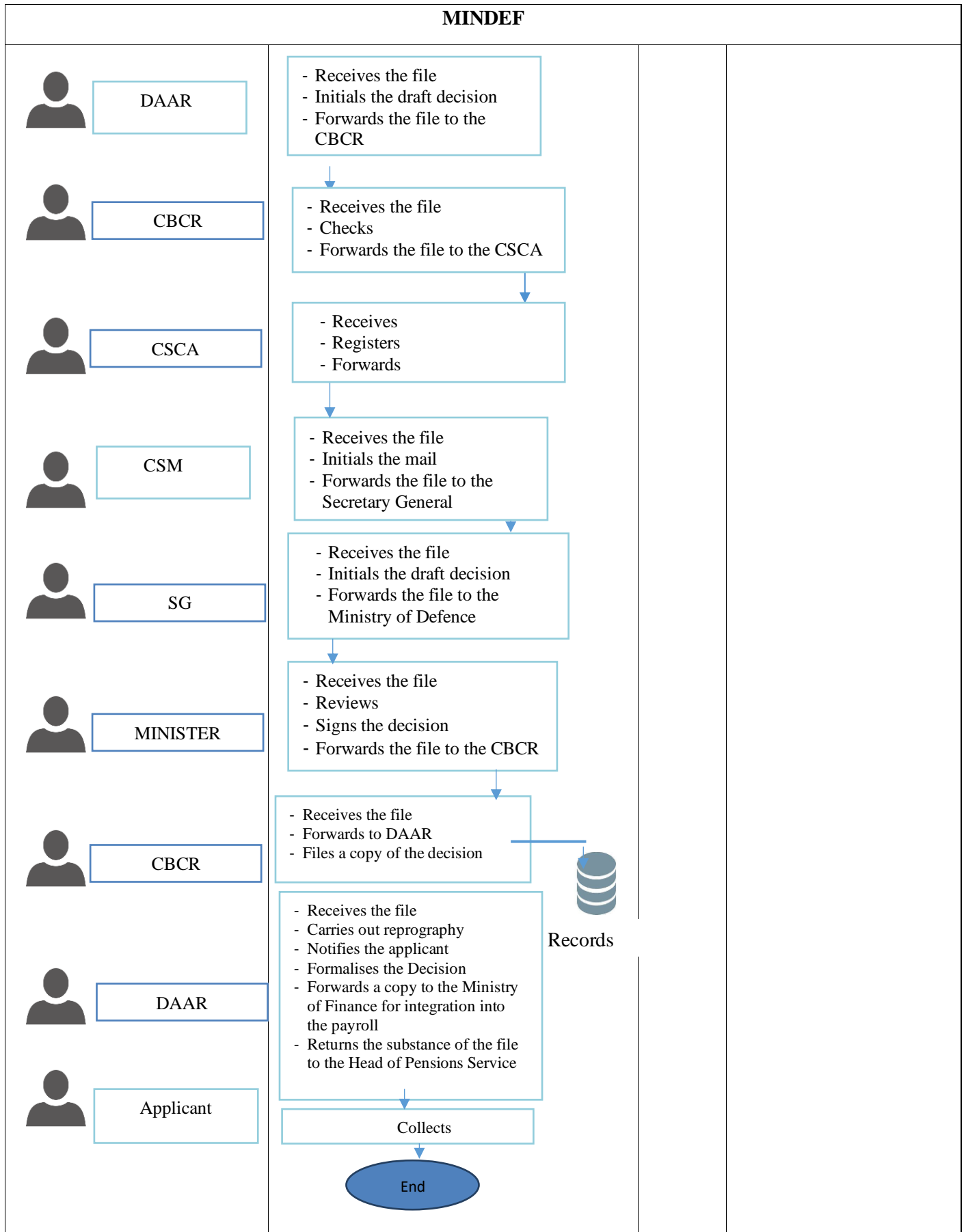

PROCEDURE No. 24/MINDEF/DAAR/PNO/I
**GRANTING OF A RETIREMENT PENSION AND REVALORISATION
OF A LIFE-LONG INVALIDITY PENSION**

TITLE OF THE INSTRUMENT: Order on the granting of a retirement pension and revalorisation of a life-long invalidity pension

INITIATOR OF THE PROCEDURE: Applicant

INITIATING ENTITY: Pensions Service

PLACE OF SUBMISSION OF FILE: Base unit

REFERENCE INSTRUMENTS:

- Law No. 67/LF/9 of 12 June 1967 on the general organisation of Defence;
- Law No. 80/12 of 14 July 1980 on general rules and regulations governing servicemen, together with all the amendments thereto;
- Decree No. 76/460 of 12 October 1976 to organise military pension schemes based on longevity of service and invalidity pensions, as amended by Decree No. 86/262 of 26 March 1986;
- Decree No. 78/488 of 09 November 1978 defining the terms and conditions for granting civilian and military pensions, life annuities, death grants and death compensation;
- Decree No. 80/257 of 15 July 1980 to lay down general rules and regulations governing the remuneration schemes applicable to military personnel of the Armed Forces, as amended by Decree No. 84/926 of 30 July 1984;
- Decree No. 82/341 of 09 August 1982 to lay down the conditions for granting death benefits;
- Decree No. 85/1092 of 02 August 1985 revalorising civilian and military pensions;
- Decree No. 2001/178 of 25 July 2001 on the general organisation of Defence and Central Staff;
- Decree No. 2001/219 of 06 August 2001 to lay down special rules and regulations governing non-commissioned officers of the Defence Forces;
- Decree No. 2004/056 of 23 March 2004 to organise the mobilisable reserve of non-commissioned officers of the Defence Forces;
- Decree No. 2008/099 of 07 March 2008 to revalorise the basic monthly salaries of civilian and military personnel;
- Decree No. 2008/311 of 27 August 2008 granting an annuity bonus to some military personnel of the Defence Forces;
- Decree No. 2010/382 of 22 December 2010 to amend Decree No. 2001/219 of 06 August 2001 to lay down special rules and regulations governing non-commissioned officers of the Defence Forces;
- Decree No. 2011/412 of 09 December 2011 to reorganise the Presidency of the Republic;
- Decree No. 2014/253 of 07 July 2014 to revalorise the basic monthly salaries of civilian and military personnel;
- Decree No. 2015/194 of 20 April 2015 granting an annuity bonus to some military personnel of the Defence Forces;
- Decree No. 2016/034 of 21 January 2016 to revalorise family allowances;
- Decree No. 2018/190 of 02 March 2018 amending and supplementing certain provisions of Decree No. 2011/408 of 09 December 2011 to organise the Government;
- Decree No. 2019/002 of 04 January 2019 to reshuffle the Government;

- Order No. 236/CAB/PR of 09 November 1978 laying down the procedure for granting civilian and military pensions, life annuities, death grants and death compensation.

REQUIREMENT: Be a retired non-commissioned service member with at least 15 years of service and entitled to an invalidity pension.

CONSTITUTION OF FILE:

- **Required documents:**

- stamped application on *papier ministre* (ledger square paper) addressed to the Minister;
- retirement order and payment from the mobilisable reserve;
- military service record;
- certificate of residence;
- certified copy of valid national identity card of the applicant;
- certified copy of birth certificate;
- certified photocopies of his/her children's birth certificates (in the case of a recognised child, the page bearing the mention of recognition must be certified);
- collective life certificate of all the children;
- original copies of school certificates of minor children for the current year;
- original copy of bank account certificate;
- last payslip with salary;
- copy of marriage certificate or certificate of celibacy;
- photocopy of divorce judgement and certificate of non-appeal or death certificate of the spouse;
- certificate of individuality (where applicable);
- Order granting invalidity pension or copy of Ministerial Decision on the invalidity of some personnel of the Defence Forces;
- certificate of conformity of date of birth (where applicable).

- **Reference documents:** Staff file

DEADLINE: Sixty (60) days

SIGNATORY OF THE INSTRUMENT: the Minister

DELIVERY METHOD: Collection

QUALITY SUPERVISOR: the Director of Administrative and Regulatory Affairs

PROCESSING: cf. **processing chain: PROCEDURE No. 01/MINDEF/DAAR/PNO/I**
GRANTING A RETIREMENT PENSION

TITLE OF THE INSTRUMENT: Order on the granting of a retirement pension, revalorisation of a life-long invalidity pension and granting of an installation allowance

INITIATOR OF THE PROCEDURE: Applicant

INITIATING ENTITY: Pensions Service

PLACE OF SUBMISSION OF FILE: Base unit

REFERENCE INSTRUMENTS:

- Law No. 67/LF/9 of 12 June 1967 on the general organisation of Defence;
- Law No. 80/12 of 14 July 1980 on general rules and regulations governing servicemen, together with all the amendments thereto;
- Decree No. 76/460 of 12 October 1976 to organise military pension schemes based on longevity of service and invalidity pensions, as amended by Decree No. 86/262 of 26 March 1986;
- Decree No. 78/488 of 09 November 1978 defining the terms and conditions for granting civilian and military pensions, life annuities, death grants and death compensation;
- Decree No. 80/257 of 15 July 1980 to lay down general rules and regulations governing the remuneration schemes applicable to military personnel of the Armed Forces, as amended by Decree No. 84/926 of 30 July 1984;
- Decree No. 82/341 of 09 August 1982 to lay down the conditions for granting death benefits;
- Decree No. 85/1092 of 02 August 1985 revalorising civilian and military pensions;
- Decree No. 2001/178 of 25 July 2001 on the general organisation of Defence and Central Staff;
- Decree No. 2001/219 of 06 August 2001 to lay down special rules and regulations governing non-commissioned officers of the Defence Forces;
- Decree No. 2004/056 of 23 March 2004 to organise the mobilisable reserve of non-commissioned officers of the Defence Forces;
- Decree No. 2008/099 of 07 March 2008 to revalorise the basic monthly salaries of civilian and military personnel;
- Decree No. 2008/311 of 27 August 2008 granting an annuity bonus to some military personnel of the Defence Forces;
- Decree No. 2010/382 of 22 December 2010 to amend Decree No. 2001/219 of 06 August 2001 to lay down special rules and regulations governing non-commissioned officers of the Defence Forces;
- Decree No. 2011/412 of 09 December 2011 to reorganise the Presidency of the Republic;
- Decree No. 2014/253 of 07 July 2014 to revalorise the basic monthly salaries of civilian and military personnel;
- Decree No. 2015/194 of 20 April 2015 granting an annuity bonus to some military personnel of the Defence Forces;
- Decree No. 2016/034 of 21 January 2016 to revalorise family allowances;
- Decree No. 2018/190 of 02 March 2018 amending and supplementing certain provisions of Decree No. 2011/408 of 09 December 2011 to organise the Government;
- Decree No. 2019/002 of 04 January 2019 to reshuffle the Government;
- Order No. 236/CAB/PR of 09 November 1978 laying down the procedure for granting civilian and military pensions, life annuities, death grants and death compensation.

REQUIREMENT: Be a retired non-commissioned service member with at least 15 years of service and entitled to an invalidity pension.

CONSTITUTION OF FILE:

- **Required documents:**
 - stamped application on *papier ministre* (ledger square paper) addressed to the Minister;
 - Order granting invalidity pension or copy of Ministerial Decision on the invalidity of some personnel of the Defence Forces;
 - Early Retirement Order;
 - military service record;
 - certificate of residence;
 - certified copy of valid national identity card of the applicant;
 - certified copy of birth certificate;
 - certified photocopies of his/her children's birth certificates (in the case of a recognised child, the page bearing the mention of recognition must be certified);
 - collective life certificate of all the children;
 - original copies of school certificates of minor children for the current year;
 - original copy of bank account certificate;
 - last payslip with salary;
 - copy of marriage certificate or certificate of celibacy;
 - photocopy of divorce judgement and certificate of non-appeal or death certificate of the spouse;
 - certificate of individuality (where applicable);
 - certificate of conformity of date of birth (where applicable);
 - invalidity pension payslip (where applicable).
- **Reference documents:** Staff file

DEADLINE: Sixty (60) days

SIGNATORY OF THE INSTRUMENT: the Minister

DELIVERY METHOD: Collection

QUALITY SUPERVISOR: the Director of Administrative and Regulatory Affairs

PROCESSING: cf. **processing chain:** PROCEDURE No. 01/MINDEF/DAAR/PNO/I
GRANTING A RETIREMENT PENSION

PROCEDURE No. 26/MINDEF/DAAR/PNO/I
**GRANTING OF A RETIREMENT PENSION, REVALORISATION OF A
LIFE-LONG INVALIDITY PENSION AND ALLOCATION OF
BENEFITS FROM THE MOBILISABLE RESERVE**

TITLE OF THE INSTRUMENT: Order on the granting of a retirement pension, revalorisation of a life-long invalidity pension and allocation of benefits from the mobilisable reserve

INITIATOR OF THE PROCEDURE: Applicant

INITIATING ENTITY: Pensions Service

PLACE OF SUBMISSION OF FILE: Base unit

REFERENCE INSTRUMENTS:

- Law No. 67/LF/9 of 12 June 1967 on the general organisation of Defence;
- Law No. 80/12 of 14 July 1980 on general rules and regulations governing servicemen, together with all the amendments thereto;
- Decree No. 76/460 of 12 October 1976 to organise military pension schemes based on longevity of service and invalidity pensions, as amended by Decree No. 86/262 of 26 March 1986;
- Decree No. 78/488 of 09 November 1978 defining the terms and conditions for granting civilian and military pensions, life annuities, death grants and death compensation;
- Decree No. 80/257 of 15 July 1980 to lay down general rules and regulations governing the remuneration schemes applicable to military personnel of the Armed Forces, as amended by Decree No. 84/926 of 30 July 1984;
- Decree No. 82/341 of 09 August 1982 to lay down the conditions for granting death benefits;
- Decree No. 85/1092 of 02 August 1985 revalorising civilian and military pensions;
- Decree No. 2001/178 of 25 July 2001 on the general organisation of Defence and Central Staff;
- Decree No. 2001/219 of 06 August 2001 to lay down special rules and regulations governing non-commissioned officers of the Defence Forces;
- Decree No. 2004/056 of 23 March 2004 to organise the mobilisable reserve of non-commissioned officers of the Defence Forces;
- Decree No. 2008/099 of 07 March 2008 to revalorise the basic monthly salaries of civilian and military personnel;
- Decree No. 2008/311 of 27 August 2008 granting an annuity bonus to some military personnel of the Defence Forces;
- Decree No. 2010/382 of 22 December 2010 to amend Decree No. 2001/219 of 06 August 2001 to lay down special rules and regulations governing non-commissioned officers of the Defence Forces;
- Decree No. 2011/412 of 09 December 2011 to reorganise the Presidency of the Republic;
- Decree No. 2014/253 of 07 July 2014 to revalorise the basic monthly salaries of civilian and military personnel;
- Decree No. 2015/194 of 20 April 2015 granting an annuity bonus to some military personnel of the Defence Forces;
- Decree No. 2016/034 of 21 January 2016 to revalorise family allowances;
- Decree No. 2018/190 of 02 March 2018 amending and supplementing certain provisions of Decree No. 2011/408 of 09 December 2011 to organise the Government;
- Decree No. 2019/002 of 04 January 2019 to reshuffle the Government;

- Order No. 236/CAB/PR of 09 November 1978 laying down the procedure for granting civilian and military pensions, life annuities, death grants and death compensation.

REQUIREMENT: Be a retired non-commissioned service member with at least 15 years of service, entitled to an invalidity pension and admitted to the mobilisable reserve.

CONSTITUTION OF FILE:

- **Required documents:**

- stamped application on *papier ministre* (ledger square paper) addressed to the Minister;
- Order granting invalidity pension or copy of Ministerial Decision on the invalidity of some personnel of the Defence Forces;
- Order on the constitution of a retirement pension;
- Order on payment from the mobilisable reserve;
- military service record;
- certificate of residence;
- certified copy of valid national identity card of the applicant;
- certified copy of birth certificate;
- certified photocopies of his/her children's birth certificates (in the case of a recognised child, the page bearing the mention of recognition must be certified);
- collective life certificate of all the children;
- original copies of school certificates of minor children for the current year;
- original copy of bank account certificate;
- last payslip with salary;
- copy of marriage certificate or certificate of celibacy;
- photocopy of divorce judgement and certificate of non-appeal or death certificate of the spouse;
- certificate of individuality (where applicable);
- certificate of conformity of date of birth (where applicable);
- invalidity pension payslip.

- **Reference documents:** N/A

DEADLINE: Sixty (60) days

SIGNATORY OF THE INSTRUMENT: the Minister

DELIVERY METHOD: Collection

QUALITY SUPERVISOR: the Director of Administrative and Regulatory Affairs

**PROCESSING: cf. processing chain: PROCEDURE No. 01/MINDEF/DAAR/PNO/I
GRANTING A RETIREMENT PENSION**

PROCEDURE No. 27/MINDEF/DAAR/PNO/I
**GRANTING A RETIREMENT PENSION AND A LIFE-LONG
INVALIDITY PENSION**

TITLE OF THE INSTRUMENT: Order granting a retirement pension and a life-long invalidity pension

INITIATOR OF THE PROCEDURE: Applicant

INITIATING ENTITY: Pensions Service

PLACE OF SUBMISSION OF FILE: Base unit

REFERENCE INSTRUMENTS:

- Law No. 67/LF/9 of 12 June 1967 on the general organisation of Defence;
- Law No. 80/12 of 14 July 1980 on general rules and regulations governing servicemen, together with all the amendments thereto;
- Decree No. 76/460 of 12 October 1976 to organise military pension schemes based on longevity of service and invalidity pensions, as amended by Decree No. 86/262 of 26 March 1986;
- Decree No. 78/488 of 09 November 1978 defining the terms and conditions for granting civilian and military pensions, life annuities, death grants and death compensation;
- Decree No. 80/257 of 15 July 1980 to lay down general rules and regulations governing the remuneration schemes applicable to military personnel of the Armed Forces, as amended by Decree No. 84/926 of 30 July 1984;
- Decree No. 82/341 of 09 August 1982 to lay down the conditions for granting death benefits;
- Decree No. 85/1092 of 02 August 1985 revalorising civilian and military pensions;
- Decree No. 2001/178 of 25 July 2001 on the general organisation of Defence and Central Staff;
- Decree No. 2001/219 of 06 August 2001 to lay down special rules and regulations governing non-commissioned officers of the Defence Forces;
- Decree No. 2004/056 of 23 March 2004 to organise the mobilisable reserve of non-commissioned officers of the Defence Forces;
- Decree No. 2008/099 of 07 March 2008 to revalorise the basic monthly salaries of civilian and military personnel;
- Decree No. 2008/311 of 27 August 2008 granting an annuity bonus to some military personnel of the Defence Forces;
- Decree No. 2010/382 of 22 December 2010 to amend Decree No. 2001/219 of 06 August 2001 to lay down special rules and regulations governing non-commissioned officers of the Defence Forces;
- Decree No. 2011/412 of 09 December 2011 to reorganise the Presidency of the Republic;
- Decree No. 2014/253 of 07 July 2014 to revalorise the basic monthly salaries of civilian and military personnel;
- Decree No. 2015/194 of 20 April 2015 granting an annuity bonus to some military personnel of the Defence Forces;
- Decree No. 2016/034 of 21 January 2016 to revalorise family allowances;
- Decree No. 2018/190 of 02 March 2018 amending and supplementing certain provisions of Decree No. 2011/408 of 09 December 2011 to organise the Government;
- Decree No. 2019/002 of 04 January 2019 to reshuffle the Government;
- Order No. 236/CAB/PR of 09 November 1978 laying down the procedure for granting civilian and military pensions, life annuities, death grants and death compensation.

REQUIREMENT: Be a retired non-commissioned service member with at least 15 years of service and entitled to an invalidity pension.

CONSTITUTION OF FILE:

- **Required documents:**
 - stamped application on *papier ministre* (ledger square paper) addressed to the Minister;
 - Retirement Order;
 - military service record;
 - certificate of residence;
 - certified copy of valid national identity card of the applicant;
 - certified copy of birth certificate;
 - certified photocopies of his/her children's birth certificates (in the case of a recognised child, the page bearing the mention of recognition must be certified);
 - collective life certificate of all the children;
 - original copies of school certificates of minor children for the current year;
 - original copy of bank account certificate;
 - last payslip with salary;
 - copy of marriage certificate or certificate of celibacy;
 - photocopy of divorce judgement and certificate of non-appeal or death certificate of the spouse;
 - certificate of individuality (where applicable);
 - certificate of conformity of date of birth (where applicable);
 - Ministerial Decision on the invalidity of some personnel of the Defence Forces.

- **Reference documents:** N/A

DEADLINE: Sixty (60) days

SIGNATORY OF THE INSTRUMENT: the Minister

DELIVERY METHOD: Collection

QUALITY SUPERVISOR: the Director of Administrative and Regulatory Affairs

PROCESSING: cf. **processing chain:** PROCEDURE No. 01/MINDEF/DAAR/PNO/I
GRANTING A RETIREMENT PENSION

TITLE OF THE INSTRUMENT: Order granting a retirement pension and a temporary invalidity pension

INITIATOR OF THE PROCEDURE: Applicant

INITIATING ENTITY: Pensions Service

PLACE OF SUBMISSION OF FILE: Base unit

REFERENCE INSTRUMENTS:

- Law No. 67/LF/9 of 12 June 1967 on the general organisation of Defence;
- Law No. 80/12 of 14 July 1980 on general rules and regulations governing servicemen, together with all the amendments thereto;
- Decree No. 76/460 of 12 October 1976 to organise military pension schemes based on longevity of service and invalidity pensions, as amended by Decree No. 86/262 of 26 March 1986;
- Decree No. 78/488 of 09 November 1978 defining the terms and conditions for granting civilian and military pensions, life annuities, death grants and death compensation;
- Decree No. 80/257 of 15 July 1980 to lay down general rules and regulations governing the remuneration schemes applicable to military personnel of the Armed Forces, as amended by Decree No. 84/926 of 30 July 1984;
- Decree No. 82/341 of 09 August 1982 to lay down the conditions for granting death benefits;
- Decree No. 85/1092 of 02 August 1985 revalorising civilian and military pensions;
- Decree No. 2001/178 of 25 July 2001 on the general organisation of Defence and Central Staff;
- Decree No. 2001/219 of 06 August 2001 to lay down special rules and regulations governing non-commissioned officers of the Defence Forces;
- Decree No. 2004/056 of 23 March 2004 to organise the mobilisable reserve of non-commissioned officers of the Defence Forces;
- Decree No. 2008/099 of 07 March 2008 to revalorise the basic monthly salaries of civilian and military personnel;
- Decree No. 2008/311 of 27 August 2008 granting an annuity bonus to some military personnel of the Defence Forces;
- Decree No. 2010/382 of 22 December 2010 to amend Decree No. 2001/219 of 06 August 2001 to lay down special rules and regulations governing non-commissioned officers of the Defence Forces;
- Decree No. 2011/412 of 09 December 2011 to reorganise the Presidency of the Republic;
- Decree No. 2014/253 of 07 July 2014 to revalorise the basic monthly salaries of civilian and military personnel;
- Decree No. 2015/194 of 20 April 2015 granting an annuity bonus to some military personnel of the Defence Forces;
- Decree No. 2016/034 of 21 January 2016 to revalorise family allowances;
- Decree No. 2018/190 of 02 March 2018 amending and supplementing certain provisions of Decree No. 2011/408 of 09 December 2011 to organise the Government;
- Decree No. 2019/002 of 04 January 2019 to reshuffle the Government;
- Order No. 236/CAB/PR of 09 November 1978 laying down the procedure for granting civilian and military pensions, life annuities, death grants and death compensation.

REQUIREMENT: Be a retired non-commissioned service member with at least 15 years of service and entitled to a temporary invalidity pension.

CONSTITUTION OF FILE:

• **Required documents:**

- stamped application on *papier ministre* (ledger square paper) addressed to the Minister;
- Retirement Order;
- military service record;
- certificate of residence;
- certified copy of valid national identity card of the applicant;
- certified copy of birth certificate;
- certified photocopies of his/her children's birth certificates (in the case of a recognised child, the page bearing the mention of recognition must be certified);
- collective life certificate of all the children;
- original copies of school certificates of minor children for the current year;
- original copy of bank account certificate;
- last payslip with salary;
- copy of marriage certificate or certificate of celibacy;
- photocopy of divorce judgement and certificate of non-appeal or death certificate of the spouse;
- certificate of individuality (where applicable);
- certificate of conformity of date of birth (where applicable);
- Ministerial Decision on the invalidity of some personnel of the Defence Forces.

• **Reference documents:** N/A

DEADLINE: Sixty (60) days

SIGNATORY OF THE INSTRUMENT: the Minister

DELIVERY METHOD: Collection

QUALITY SUPERVISOR: the Director of Administrative and Regulatory Affairs

PROCESSING: cf. **processing chain:** PROCEDURE No. 01/MINDEF/DAAR/PNO/I
GRANTING A RETIREMENT PENSION

PROCEDURE No. 29/MINDEF/DAAR/PNO/I
**GRANTING OF A RETIREMENT PENSION, REVALORISATION OF A LIFE-
LONG INVALIDITY PENSION, ALLOCATION OF BENEFITS FROM
THE MOBILISABLE RESERVE AND GRANTING OF AN
INSTALLATION ALLOWANCE**

TITLE OF THE INSTRUMENT : Order on the granting of a retirement pension, revalorisation of a life-long invalidity pension, allocation of benefits from the mobilisable reserve and granting of an installation allowance

INITIATOR OF THE PROCEDURE: Applicant

INITIATING ENTITY: Pensions Service

PLACE OF SUBMISSION OF FILE: Base unit

REFERENCE INSTRUMENTS:

- Law No. 67/LF/9 of 12 June 1967 on the general organisation of Defence;
- Law No. 80/12 of 14 July 1980 on general rules and regulations governing servicemen, together with all the amendments thereto;
- Decree No. 76/460 of 12 October 1976 to organise military pension schemes based on longevity of service and invalidity pensions, as amended by Decree No. 86/262 of 26 March 1986;
- Decree No. 78/488 of 09 November 1978 defining the terms and conditions for granting civilian and military pensions, life annuities, death grants and death compensation;
- Decree No. 80/257 of 15 July 1980 to lay down general rules and regulations governing the remuneration schemes applicable to military personnel of the Armed Forces, as amended by Decree No. 84/926 of 30 July 1984;
- Decree No. 82/341 of 09 August 1982 to lay down the conditions for granting death benefits;
- Decree No. 85/1092 of 02 August 1985 revalorising civilian and military pensions;
- Decree No. 2001/178 of 25 July 2001 on the general organisation of Defence and Central Staff;
- Decree No. 2001/219 of 06 August 2001 to lay down special rules and regulations governing non-commissioned officers of the Defence Forces;
- Decree No. 2004/056 of 23 March 2004 to organise the mobilisable reserve of non-commissioned officers of the Defence Forces;
- Decree No. 2008/099 of 07 March 2008 to revalorise the basic monthly salaries of civilian and military personnel;
- Decree No. 2008/311 of 27 August 2008 granting an annuity bonus to some military personnel of the Defence Forces;
- Decree No. 2010/382 of 22 December 2010 to amend Decree No. 2001/219 of 06 August 2001 to lay down special rules and regulations governing non-commissioned officers of the Defence Forces;
- Decree No. 2011/412 of 09 December 2011 to reorganise the Presidency of the Republic;
- Decree No. 2014/253 of 07 July 2014 to revalorise the basic monthly salaries of civilian and military personnel;
- Decree No. 2015/194 of 20 April 2015 granting an annuity bonus to some military personnel of the Defence Forces;
- Decree No. 2016/034 of 21 January 2016 to revalorise family allowances;
- Decree No. 2018/190 of 02 March 2018 amending and supplementing certain provisions of Decree No. 2011/408 of 09 December 2011 to organise the Government;
- Decree No. 2019/002 of 04 January 2019 to reshuffle the Government;

- Order No. 236/CAB/PR of 09 November 1978 laying down the procedure for granting civilian and military pensions, life annuities, death grants and death compensation.

REQUIREMENTS:

- be a retired non-commissioned service member with at least 15 years of service and entitled to a life-long invalidity pension;
- be admitted to the mobilisable reserve.

CONSTITUTION OF FILE:

- **Required documents:**

- stamped application on *papier ministre* (ledger square paper) addressed to the Minister;
- Order granting invalidity pension or copy of Ministerial Decision on the invalidity of some personnel of the Defence Forces;
- Early Retirement Order;
- military service record;
- certificate of residence;
- certified copy of valid national identity card of the applicant;
- certified copy of birth certificate;
- certified photocopies of his/her children's birth certificates (in the case of a recognised child, the page bearing the mention of recognition must be certified);
- collective life certificate of all the children;
- original copies of school certificates of minor children for the current year;
- original copy of bank account certificate;
- last payslip with salary;
- copy of marriage certificate or certificate of celibacy;
- photocopy of divorce judgement and certificate of non-appeal or death certificate of the spouse;
- decree on payment from the mobilisable reserve;
- certificate of individuality (where applicable);
- certificate of conformity of date of birth (where applicable);
- invalidity pension payslip (where applicable);
- invalidity pension payslip (where applicable).

- **Reference documents:** Staff file

DEADLINE: Sixty (60) days

SIGNATORY OF THE INSTRUMENT: the Minister

DELIVERY METHOD: Collection

QUALITY SUPERVISOR: the Director of Administrative and Regulatory Affairs

PROCESSING: cf. **processing chain: PROCEDURE No. 01/MINDEF/DAAR/PNO/I
GRANTING A RETIREMENT PENSION**

PROCEDURE No. 30/MINDEF/DAAR/PNO/1
**ALLOCATING BENEFITS FROM THE MOBILISABLE
RESERVE**

TITLE OF THE INSTRUMENT: Order allocating benefits from the mobilisable reserve

INITIATOR OF THE PROCEDURE: Applicant

INITIATING ENTITY: Pensions Service

PLACE OF SUBMISSION OF FILE: Base unit

REFERENCE INSTRUMENTS:

- Law No. 67/LF/9 of 12 June 1967 on the general organisation of Defence;
- Law No. 80/12 of 14 July 1980 on general rules and regulations governing servicemen, together with all the amendments thereto;
- Decree No. 76/460 of 12 October 1976 to organise military pension schemes based on longevity of service and invalidity pensions, as amended by Decree No. 86/262 of 26 March 1986;
- Decree No. 78/488 of 09 November 1978 defining the terms and conditions for granting civilian and military pensions, life annuities, death grants and death compensation;
- Decree No. 80/257 of 15 July 1980 to lay down general rules and regulations governing the remuneration schemes applicable to military personnel of the Armed Forces, as amended by Decree No. 84/926 of 30 July 1984;
- Decree No. 82/341 of 09 August 1982 to lay down the conditions for granting death benefits;
- Decree No. 85/1092 of 02 August 1985 revalorising civilian and military pensions;
- Decree No. 2001/178 of 25 July 2001 on the general organisation of Defence and Central Staff;
- Decree No. 2001/219 of 06 August 2001 to lay down special rules and regulations governing non-commissioned officers of the Defence Forces;
- Decree No. 2004/056 of 23 March 2004 to organise the mobilisable reserve of non-commissioned officers of the Defence Forces;
- Decree No. 2008/099 of 07 March 2008 to revalorise the basic monthly salaries of civilian and military personnel;
- Decree No. 2008/311 of 27 August 2008 granting an annuity bonus to some military personnel of the Defence Forces;
- Decree No. 2010/382 of 22 December 2010 to amend Decree No. 2001/219 of 06 August 2001 to lay down special rules and regulations governing non-commissioned officers of the Defence Forces;
- Decree No. 2011/412 of 09 December 2011 to reorganise the Presidency of the Republic;
- Decree No. 2014/253 of 07 July 2014 to revalorise the basic monthly salaries of civilian and military personnel;
- Decree No. 2015/194 of 20 April 2015 granting an annuity bonus to some military personnel of the Defence Forces;
- Decree No. 2016/034 of 21 January 2016 to revalorise family allowances;
- Decree No. 2018/190 of 02 March 2018 amending and supplementing certain provisions of Decree No. 2011/408 of 09 December 2011 to organise the Government;
- Decree No. 2019/002 of 04 January 2019 to reshuffle the Government;
- Order No. 236/CAB/PR of 09 November 1978 laying down the procedure for granting civilian and military pensions, life annuities, death grants and death compensation.

REQUIREMENT: Be a non-commissioned service member paid from the mobilisable reserve.

CONSTITUTION OF FILE:

- **Required documents:**
 - stamped application on *papier ministre* (ledger square paper) addressed to the Minister;
 - certificate of residence;
 - decree on payment from the mobilisable reserve;
 - certified copy of valid national identity card of the applicant;
 - certified copy of birth certificate;
 - certified photocopies of his/her children's birth certificates (in the case of a recognised child, the page bearing the mention of recognition must be certified);
 - collective life certificate of all the children;
 - original copies of school certificates of minor children for the current year;
 - original copy of bank account certificate;
 - last payslip with salary;
 - copy of marriage certificate or certificate of celibacy;
 - photocopy of divorce judgement and certificate of non-appeal or death certificate of the spouse;
 - certificate of individuality (where applicable);
 - certificate of conformity of date of birth (where applicable);
 - invalidity pension payslip (where applicable);
 - pension payslip.
- **Reference documents:** Staff file

DEADLINE: Sixty (60) days

SIGNATORY OF THE INSTRUMENT: the Minister

DELIVERY METHOD: Collection

QUALITY SUPERVISOR: the Director of Administrative and Regulatory Affairs

**PROCESSING: cf. processing chain: PROCEDURE No. 01/MINDEF/DAAR/PNO/I
GRANTING A RETIREMENT PENSION**

PROCEDURE No. 31/MINDEF/DAAR/PNO/I
**GRANTING AND REVERSION OF A RETIREMENT PENSION,
REVALORISATION AND REVERSION OF A LIFE-LONG
INVALIDITY PENSION, ALLOCATION AND REVERSION OF
BENEFITS FROM THE MOBILISABLE RESERVE**

TITLE OF THE INSTRUMENT: Order on the portant granting and reversion of a retirement pension, revalorisation and reversion of a life-long invalidity pension, allocation and reversion of benefits from the mobilisable reserve

INITIATOR OF THE PROCEDURE: Applicant

INITIATING ENTITY: Pensions Service

PLACE OF SUBMISSION OF FILE: Base unit

REFERENCE INSTRUMENTS:

- Law No. 67/LF/9 of 12 June 1967 on the general organisation of Defence;
- Law No. 80/12 of 14 July 1980 on general rules and regulations governing servicemen, together with all the amendments thereto;
- Decree No. 76/460 of 12 October 1976 to organise military pension schemes based on longevity of service and invalidity pensions, as amended by Decree No. 86/262 of 26 March 1986;
- Decree No. 78/488 of 09 November 1978 defining the terms and conditions for granting civilian and military pensions, life annuities, death grants and death compensation;
- Decree No. 80/257 of 15 July 1980 to lay down general rules and regulations governing the remuneration schemes applicable to military personnel of the Armed Forces, as amended by Decree No. 84/926 of 30 July 1984;
- Decree No. 82/341 of 09 August 1982 to lay down the conditions for granting death benefits;
- Decree No. 85/1092 of 02 August 1985 revalorising civilian and military pensions;
- Decree No. 2001/178 of 25 July 2001 on the general organisation of Defence and Central Staff;
- Decree No. 2001/219 of 06 August 2001 to lay down special rules and regulations governing non-commissioned officers of the Defence Forces;
- Decree No. 2004/056 of 23 March 2004 to organise the mobilisable reserve of non-commissioned officers of the Defence Forces;
- Decree No. 2008/099 of 07 March 2008 to revalorise the basic monthly salaries of civilian and military personnel;
- Decree No. 2008/311 of 27 August 2008 granting an annuity bonus to some military personnel of the Defence Forces;
- Decree No. 2010/382 of 22 December 2010 to amend Decree No. 2001/219 of 06 August 2001 to lay down special rules and regulations governing non-commissioned officers of the Defence Forces;
- Decree No. 2011/412 of 09 December 2011 to reorganise the Presidency of the Republic;
- Decree No. 2014/253 of 07 July 2014 to revalorise the basic monthly salaries of civilian and military personnel;
- Decree No. 2015/194 of 20 April 2015 granting an annuity bonus to some military personnel of the Defence Forces;
- Decree No. 2016/034 of 21 January 2016 to revalorise family allowances;
- Decree No. 2018/190 of 02 March 2018 amending and supplementing certain provisions of Decree No. 2011/408 of 09 December 2011 to organise the Government;
- Decree No. 2019/002 of 04 January 2019 to reshuffle the Government;

- Order No. 236/CAB/PR of 09 November 1978 laying down the procedure for granting civilian and military pensions, life annuities, death grants and death compensation.

REQUIREMENT: Be the heir of a retired officer who was being paid from the mobilisable reserve and died without receiving his/her full retirement and invalidity pensions.

CONSTITUTION OF FILE:

- **Required documents:**

- stamped application on *papier ministre* (ledger square paper) addressed to the Minister;
- order granting invalidity pension or copy of the Ministerial Decision on the invalidity of some personnel of the Defence Forces;
- Early Retirement Order;
- military service record;
- certificate of residence;
- certified copy of valid national identity card of the applicant;
- certified copy of birth certificate;
- certified photocopies of his/her children's birth certificates (in the case of a recognised child, the page bearing the mention of recognition must be certified);
- collective life certificate of all the children;
- photocopy of inheritance judgement;
- photocopy of non-appeal certificate of the inheritance judgement;
- null payslip of the deceased service member;
- copy of death certificate of the service member (established at the council of the place of death);
- certificate of monogamy or polygamy;
- certificate(s) of non-divorce, non-separation and non-remarriage;
- original copies of school certificates of minor children for the current year;
- original copy of bank account certificate;
- last payslip with salary;
- copy of marriage certificate or certificate of celibacy;
- certificates of non-remarriage, non-separation, non-cohabitation and non-divorce;
- photocopy of divorce judgement and certificate of non-appeal or death certificate of the spouse;
- Order on payment from the mobilisable reserve;
- certificate of individuality (where applicable);
- certificate of conformity of date of birth (where applicable);
- invalidity pension payslip (where applicable);
- invalidity pension payslip (where applicable);
- certificate of conformity of date of birth (where applicable).

- **Reference document:** Staff file

DEADLINE: Sixty (60) days

SIGNATORY OF THE INSTRUMENT: the Minister

DELIVERY METHOD: Collection

QUALITY SUPERVISOR: the Director of Administrative and Regulatory Affairs

NOTA BENE: This situation arises when a non-commissioned service member who is benefitting from an invalidity pension retires and is placed in the mobilisable reserve, but dies before having constituted his/her file. In this case, the benefits from the mobilisable reserve are repaid in proportion to the time spent there.

**PROCESSING: cf. processing chain: PROCEDURE No. 01/MINDEF/DAAR/PNO/I
GRANTING A RETIREMENT PENSION**

PROCEDURE No. 32/MINDEF/DAAR/PNO/I
GRANTING A LIFE-LONG INVALIDITY PENSION

TITLE OF THE INSTRUMENT: Order granting a life-long invalidity pension

INITIATOR OF THE PROCEDURE: Applicant

INITIATING ENTITY: Pensions Service

PLACE OF SUBMISSION OF FILE: Base unit

REFERENCE INSTRUMENTS:

- Law No. 67/LF/9 of 12 June 1967 on the general organisation of Defence;
- Law No. 80/12 of 14 July 1980 on general rules and regulations governing servicemen, together with all the amendments thereto;
- Decree No. 76/460 of 12 October 1976 to organise military pension schemes based on longevity of service and invalidity pensions, as amended by Decree No. 86/262 of 26 March 1986;
- Decree No. 78/488 of 09 November 1978 defining the terms and conditions for granting civilian and military pensions, life annuities, death grants and death compensation;
- Decree No. 80/257 of 15 July 1980 to lay down general rules and regulations governing the remuneration schemes applicable to military personnel of the Armed Forces, as amended by Decree No. 84/926 of 30 July 1984;
- Decree No. 82/341 of 09 August 1982 to lay down the conditions for granting death benefits;
- Decree No. 85/1092 of 02 August 1985 revalorising civilian and military pensions;
- Decree No. 2001/178 of 25 July 2001 on the general organisation of Defence and Central Staff;
- Decree No. 2001/219 of 06 August 2001 to lay down special rules and regulations governing non-commissioned officers of the Defence Forces;
- Decree No. 2004/056 of 23 March 2004 to organise the mobilisable reserve of non-commissioned officers of the Defence Forces;
- Decree No. 2008/099 of 07 March 2008 to revalorise the basic monthly salaries of civilian and military personnel;
- Decree No. 2008/311 of 27 August 2008 granting an annuity bonus to some military personnel of the Defence Forces;
- Decree No. 2010/382 of 22 December 2010 to amend Decree No. 2001/219 of 06 August 2001 to lay down special rules and regulations governing non-commissioned officers of the Defence Forces;
- Decree No. 2011/412 of 09 December 2011 to reorganise the Presidency of the Republic;
- Decree No. 2014/253 of 07 July 2014 to revalorise the basic monthly salaries of civilian and military personnel;
- Decree No. 2015/194 of 20 April 2015 granting an annuity bonus to some military personnel of the Defence Forces;
- Decree No. 2016/034 of 21 January 2016 to revalorise family allowances;
- Decree No. 2018/190 of 02 March 2018 amending and supplementing certain provisions of Decree No. 2011/408 of 09 December 2011 to organise the Government;
- Decree No. 2019/002 of 04 January 2019 to reshuffle the Government;
- Order No. 236/CAB/PR of 09 November 1978 laying down the procedure for granting civilian and military pensions, life annuities, death grants and death compensation.

REQUIREMENT: Be a non-commissioned service member entitled to an invalidity pension.

CONSTITUTION OF FILE:

- **Required documents:**
 - stamped application on *papier ministre* (ledger square paper) addressed to the Minister;
 - Ministerial Decision on the invalidity of some personnel of the Defence Forces;
 - certified copy of valid national identity card of the applicant;
 - original copy of bank account certificate;
 - certificate of residence;
 - certified copy of birth certificate;
 - recent payslip;
 - certificate of individuality (where applicable);
 - certificate of conformity of date of birth (where applicable);
 - certified copy of the instrument granting the retirement pension (for retired officers).

- **Reference document:** Staff file

DEADLINE: Sixty (60) days

SIGNATORY OF THE INSTRUMENT: the Minister

DELIVERY METHOD: Collection

QUALITY SUPERVISOR: the Director of Administrative and Regulatory Affairs

PROCESSING: cf. **processing chain: PROCEDURE No. 01/MINDEF/DAAR/PNO/I**
GRANTING A RETIREMENT PENSION

PROCEDURE No. 33/MINDEF/DAAR/PNO/I
GRANTING A TEMPORARY INVALIDITY PENSION

TITLE OF THE INSTRUMENT: Order granting a temporary invalidity pension

INITIATOR OF THE PROCEDURE: Applicant

INITIATING ENTITY: Pensions Service

PLACE OF SUBMISSION OF FILE: Base unit

REFERENCE INSTRUMENTS:

- Law No. 67/LF/9 of 12 June 1967 on the general organisation of Defence;
- Law No. 80/12 of 14 July 1980 on general rules and regulations governing servicemen, together with all the amendments thereto;
- Decree No. 76/460 of 12 October 1976 to organise military pension schemes based on longevity of service and invalidity pensions, as amended by Decree No. 86/262 of 26 March 1986;
- Decree No. 78/488 of 09 November 1978 defining the terms and conditions for granting civilian and military pensions, life annuities, death grants and death compensation;
- Decree No. 80/257 of 15 July 1980 to lay down general rules and regulations governing the remuneration schemes applicable to military personnel of the Armed Forces, as amended by Decree No. 84/926 of 30 July 1984;
- Decree No. 82/341 of 09 August 1982 to lay down the conditions for granting death benefits;
- Decree No. 85/1092 of 02 August 1985 revalorising civilian and military pensions;
- Decree No. 2001/178 of 25 July 2001 on the general organisation of Defence and Central Staff;
- Decree No. 2001/219 of 06 August 2001 to lay down special rules and regulations governing non-commissioned officers of the Defence Forces;
- Decree No. 2004/056 of 23 March 2004 to organise the mobilisable reserve of non-commissioned officers of the Defence Forces;
- Decree No. 2008/099 of 07 March 2008 to revalorise the basic monthly salaries of civilian and military personnel;
- Decree No. 2008/311 of 27 August 2008 granting an annuity bonus to some military personnel of the Defence Forces;
- Decree No. 2010/382 of 22 December 2010 to amend Decree No. 2001/219 of 06 August 2001 to lay down special rules and regulations governing non-commissioned officers of the Defence Forces;
- Decree No. 2011/412 of 09 December 2011 to reorganise the Presidency of the Republic;
- Decree No. 2014/253 of 07 July 2014 to revalorise the basic monthly salaries of civilian and military personnel;
- Decree No. 2015/194 of 20 April 2015 granting an annuity bonus to some military personnel of the Defence Forces;
- Decree No. 2016/034 of 21 January 2016 to revalorise family allowances;
- Decree No. 2018/190 of 02 March 2018 amending and supplementing certain provisions of Decree No. 2011/408 of 09 December 2011 to organise the Government;
- Decree No. 2019/002 of 04 January 2019 to reshuffle the Government;
- Order No. 236/CAB/PR of 09 November 1978 laying down the procedure for granting civilian and military pensions, life annuities, death grants and death compensation.

REQUIREMENT: Be a non-commissioned service member with a documented disability.

CONSTITUTION OF FILE:

- **Required documents:**
 - stamped application on *papier ministre* (ledger square paper) addressed to the Minister;
 - copy of Ministerial Decision on the invalidity of some personnel of the Defence Forces;
 - certified copy of valid national identity card of the applicant;
 - original copy of bank account certificate;
 - certificate of residence;
 - certified copy of birth certificate;
 - recent payslip;
 - certificate of individuality (where applicable);
 - certificate of conformity of date of birth (where applicable);
 - certified copy of the instrument granting the retirement pension (for retired officers).
- **Reference document:** Staff file

DEADLINE: Sixty (60) days

SIGNATORY OF THE INSTRUMENT: the Minister

DELIVERY METHOD: Collection

QUALITY SUPERVISOR: the Director of Administrative and Regulatory Affairs

**PROCESSING: cf. processing chain: PROCEDURE No. 01/MINDEF/DAAR/PNO/I
GRANTING A RETIREMENT PENSION**

PROCEDURE No. 34/MINDEF/DAAR/PNO/I
GRANTING DEATH BENEFITS AND A REVERSIONARY PENSION

TITLE OF THE INSTRUMENT: Order granting death benefits and a reversionary pension

INITIATOR OF THE PROCEDURE: Applicant

INITIATING ENTITY: Pensions Service

PLACE OF SUBMISSION OF FILE: Base unit

REFERENCE INSTRUMENTS:

- Law No. 67/LF/9 of 12 June 1967 on the general organisation of Defence;
- Law No. 80/12 of 14 July 1980 on general rules and regulations governing servicemen, together with all the amendments thereto;
- Decree No. 76/460 of 12 October 1976 to organise military pension schemes based on longevity of service and invalidity pensions, as amended by Decree No. 86/262 of 26 March 1986;
- Decree No. 78/488 of 09 November 1978 defining the terms and conditions for granting civilian and military pensions, life annuities, death grants and death compensation;
- Decree No. 80/257 of 15 July 1980 to lay down general rules and regulations governing the remuneration schemes applicable to military personnel of the Armed Forces, as amended by Decree No. 84/926 of 30 July 1984;
- Decree No. 82/341 of 09 August 1982 to lay down the conditions for granting death benefits;
- Decree No. 85/1092 of 02 August 1985 revalorising civilian and military pensions;
- Decree No. 2001/178 of 25 July 2001 on the general organisation of Defence and Central Staff;
- Decree No. 2001/219 of 06 August 2001 to lay down special rules and regulations governing non-commissioned officers of the Defence Forces;
- Decree No. 2004/056 of 23 March 2004 to organise the mobilisable reserve of non-commissioned officers of the Defence Forces;
- Decree No. 2008/099 of 07 March 2008 to revalorise the basic monthly salaries of civilian and military personnel;
- Decree No. 2008/311 of 27 August 2008 granting an annuity bonus to some military personnel of the Defence Forces;
- Decree No. 2010/382 of 22 December 2010 to amend Decree No. 2001/219 of 06 August 2001 to lay down special rules and regulations governing non-commissioned officers of the Defence Forces;
- Decree No. 2011/412 of 09 December 2011 to reorganise the Presidency of the Republic;
- Decree No. 2014/253 of 07 July 2014 to revalorise the basic monthly salaries of civilian and military personnel;
- Decree No. 2015/194 of 20 April 2015 granting an annuity bonus to some military personnel of the Defence Forces;
- Decree No. 2016/034 of 21 January 2016 to revalorise family allowances;
- Decree No. 2018/190 of 02 March 2018 amending and supplementing certain provisions of Decree No. 2011/408 of 09 December 2011 to organise the Government;
- Decree No. 2019/002 of 04 January 2019 to reshuffle the Government;
- Order No. 236/CAB/PR of 09 November 1978 laying down the procedure for granting civilian and military pensions, life annuities, death grants and death compensation.

REQUIREMENT: Be the heir of a non-commissioned service member who died in active service.

CONSTITUTION OF FILE:

- **Required documents:**
 - stamped application on *papier ministre* (ledger square paper) addressed to the Minister;
 - military service record;
 - certified photocopy of the spouse's valid national identity card;
 - certificate of residence;
 - copy(ies) of marriage certificate(s);
 - certificate of monogamy or polygamy;
 - certificate(s) of non-divorce, non-separation and non-remarriage;
 - certified photocopies of his/her children's birth certificates (in the case of a recognised child, the page bearing the mention of recognition must be certified);
 - collective life certificate of all the children;
 - copy of death certificate of the service member (established at the council of the place of death);
 - original copies of school certificates of minor children for the current year;
 - payslip for the month in which the service member died;
 - null payslip of the deceased service member;
 - order granting invalidity pension or copy of the Ministerial Decision on the invalidity of some personnel of the Defence Forces;
 - photocopy of inheritance judgement;
 - photocopy of non-appeal certificate of the inheritance judgement;
 - certificate of individuality (where applicable);
 - Unit Commander's report on the circumstances of the death (where applicable);
 - certificate of conformity of date of birth (where applicable);
 - invalidity pension payslip (where applicable).
- **Reference document:** Staff file

DEADLINE: Sixty (60) days

SIGNATORY OF THE INSTRUMENT: the Minister

DELIVERY METHOD: Collection

QUALITY SUPERVISOR: the Director of Administrative and Regulatory Affairs

PROCESSING: cf. processing chain: PROCEDURE No. 01/MINDEF/DAAR/PNO/I
GRANTING A RETIREMENT PENSION

PROCEDURE No. 35/MINDEF/DAAR/PNO/I
**GRANTING OF DEATHS BENEFITS, A REVERSIONARY PENSION
AND REVERSION OF A LIFE-LONG INVALIDITY PENSION**

TITLE OF THE INSTRUMENT: Order on the granting of deaths benefits, a reversionary pension and reversion of a life-long invalidity pension

INITIATOR OF THE PROCEDURE: Applicant

INITIATING ENTITY: Pensions Service

PLACE OF SUBMISSION OF FILE: Base unit

REFERENCE INSTRUMENTS:

- Law No. 67/LF/9 of 12 June 1967 on the general organisation of Defence;
- Law No. 80/12 of 14 July 1980 on general rules and regulations governing servicemen, together with all the amendments thereto;
- Decree No. 76/460 of 12 October 1976 to organise military pension schemes based on longevity of service and invalidity pensions, as amended by Decree No. 86/262 of 26 March 1986;
- Decree No. 78/488 of 09 November 1978 defining the terms and conditions for granting civilian and military pensions, life annuities, death grants and death compensation;
- Decree No. 80/257 of 15 July 1980 to lay down general rules and regulations governing the remuneration schemes applicable to military personnel of the Armed Forces, as amended by Decree No. 84/926 of 30 July 1984;
- Decree No. 82/341 of 09 August 1982 to lay down the conditions for granting death benefits;
- Decree No. 85/1092 of 02 August 1985 revalorising civilian and military pensions;
- Decree No. 2001/178 of 25 July 2001 on the general organisation of Defence and Central Staff;
- Decree No. 2001/219 of 06 August 2001 to lay down special rules and regulations governing non-commissioned officers of the Defence Forces;
- Decree No. 2004/056 of 23 March 2004 to organise the mobilisable reserve of non-commissioned officers of the Defence Forces;
- Decree No. 2008/099 of 07 March 2008 to revalorise the basic monthly salaries of civilian and military personnel;
- Decree No. 2008/311 of 27 August 2008 granting an annuity bonus to some military personnel of the Defence Forces;
- Decree No. 2010/382 of 22 December 2010 to amend Decree No. 2001/219 of 06 August 2001 to lay down special rules and regulations governing non-commissioned officers of the Defence Forces;
- Decree No. 2011/412 of 09 December 2011 to reorganise the Presidency of the Republic;
- Decree No. 2014/253 of 07 July 2014 to revalorise the basic monthly salaries of civilian and military personnel;
- Decree No. 2015/194 of 20 April 2015 granting an annuity bonus to some military personnel of the Defence Forces;
- Decree No. 2016/034 of 21 January 2016 to revalorise family allowances;
- Decree No. 2018/190 of 02 March 2018 amending and supplementing certain provisions of Decree No. 2011/408 of 09 December 2011 to organise the Government;
- Decree No. 2019/002 of 04 January 2019 to reshuffle the Government;
- Order No. 236/CAB/PR of 09 November 1978 laying down the procedure for granting civilian and military pensions, life annuities, death grants and death compensation.

REQUIREMENT: Be the heir/rightful claimant of an non-commissioned service member who died in active service and was entitled to an invalidity pension.

CONSTITUTION OF FILE:

• **Required documents:**

- stamped application on *papier ministre* (ledger square paper) addressed to the Minister;
- military service record;
- certified photocopy of the spouse's valid national identity card;
- certificate of residence;
- copy(ies) of marriage certificate(s);
- certificate of monogamy or polygamy;
- certificate(s) of non-divorce, non-separation and non-remarriage;
- certified photocopies of his/her children's birth certificates (in the case of a recognised child, the page bearing the mention of recognition must be certified);
- collective life certificate of all the children;
- copy of death certificate of the service member (established at the council of the place of death);
- original copies of school certificates of minor children for the current year;
- payslip for the month in which the service member died;
- null payslip of the deceased service member;
- photocopy of inheritance judgement;
- Ministerial Decision on the invalidity of some personnel of the Defence Forces;
- photocopy of non-appeal certificate of the inheritance judgement;
- certificate of individuality (where applicable);
- Unit Commander's report on the circumstances of the death (where applicable);
- certificate of conformity of date of birth (where applicable);
- invalidity pension payslip (where applicable).

• **Reference documents:** Staff file

DEADLINE: Sixty (60) days

SIGNATORY OF THE INSTRUMENT: the Minister

DELIVERY METHOD: Collection

QUALITY SUPERVISOR: the Director of Administrative and Regulatory Affairs

PROCESSING: cf. **processing chain:** PROCEDURE No. 01/MINDEF/DAAR/PNO/I
GRANTING A RETIREMENT PENSION

PROCEDURE No. 36/MINDEF/DAAR/PNO/I
GRANTING ORPHAN'S TEMPORARY PENSION

TITLE OF THE INSTRUMENT: Order granting orphan's temporary pension

INITIATOR OF THE PROCEDURE: Applicant

INITIATING ENTITY: Pensions Service

PLACE OF SUBMISSION OF FILE: Base unit

REFERENCE INSTRUMENTS:

- Law No. 67/LF/9 of 12 June 1967 on the general organisation of Defence;
- Law No. 80/12 of 14 July 1980 on general rules and regulations governing servicemen, together with all the amendments thereto;
- Decree No. 76/460 of 12 October 1976 to organise military pension schemes based on longevity of service and invalidity pensions, as amended by Decree No. 86/262 of 26 March 1986;
- Decree No. 78/488 of 09 November 1978 defining the terms and conditions for granting civilian and military pensions, life annuities, death grants and death compensation;
- Decree No. 80/257 of 15 July 1980 to lay down general rules and regulations governing the remuneration schemes applicable to military personnel of the Armed Forces, as amended by Decree No. 84/926 of 30 July 1984;
- Decree No. 82/341 of 09 August 1982 to lay down the conditions for granting death benefits;
- Decree No. 85/1092 of 02 August 1985 revalorising civilian and military pensions;
- Decree No. 2001/178 of 25 July 2001 on the general organisation of Defence and Central Staff;
- Decree No. 2001/219 of 06 August 2001 to lay down special rules and regulations governing non-commissioned officers of the Defence Forces;
- Decree No. 2004/056 of 23 March 2004 to organise the mobilisable reserve of non-commissioned officers of the Defence Forces;
- Decree No. 2008/099 of 07 March 2008 to revalorise the basic monthly salaries of civilian and military personnel;
- Decree No. 2008/311 of 27 August 2008 granting an annuity bonus to some military personnel of the Defence Forces;
- Decree No. 2010/382 of 22 December 2010 to amend Decree No. 2001/219 of 06 August 2001 to lay down special rules and regulations governing non-commissioned officers of the Defence Forces;
- Decree No. 2011/412 of 09 December 2011 to reorganise the Presidency of the Republic;
- Decree No. 2014/253 of 07 July 2014 to revalorise the basic monthly salaries of civilian and military personnel;
- Decree No. 2015/194 of 20 April 2015 granting an annuity bonus to some military personnel of the Defence Forces;
- Decree No. 2016/034 of 21 January 2016 to revalorise family allowances;
- Decree No. 2018/190 of 02 March 2018 amending and supplementing certain provisions of Decree No. 2011/408 of 09 December 2011 to organise the Government;
- Decree No. 2019/002 of 04 January 2019 to reshuffle the Government;
- Order No. 236/CAB/PR of 09 November 1978 laying down the procedure for granting civilian and military pensions, life annuities, death grants and death compensation.

REQUIREMENT: Be an orphan following the death of an unmarried non-commissioned service member parent.

CONSTITUTION OF FILE:

• **Required documents:**

- stamped application on *papier ministre* (ledger square paper) addressed to the Minister;
- copy of death certificate of the service member (established at the council of the place of death);
- photocopy of guardianship judgement;
- certified photocopy of non-appeal certificate;
- guardian’s certificate of residence;
- certified copy of guardian’s valid national identity card;
- certified photocopies of his/her children’s birth certificates (in the case of a recognised child, the page bearing the mention of recognition must be certified);
- collective life certificate of all the children;
- original copies of school certificates of minor children for the current year;
- payslip for the month in which the service member died;
- null payslip of the deceased service member;
- pensioner’s payslip;
- certificate of individuality (where applicable);
- certificate of celibacy of the deceased service member;
- military service record of the deceased service member;
- copies of marriage and death certificates of the spouse;
- photocopy of inheritance judgement;
- photocopy of non-appeal certificate of the inheritance judgement;
- certificate of conformity of date of birth (where applicable);
- Decree granting a retirement pension (where applicable).

• **Reference documents:** Staff file

DEADLINE: Sixty (60) days

SIGNATORY OF THE INSTRUMENT: the Minister

DELIVERY METHOD: Collection

QUALITY SUPERVISOR: the Director of Administrative and Regulatory Affairs

**PROCESSING: cf. processing chain: PROCEDURE No. 01/MINDEF/DAAR/PNO/I
GRANTING A RETIREMENT PENSION**

PROCEDURE No.37/MINDEF/DAAR/PNO/I
**GRANTING DEATH BENEFITS AND ORPHAN'S TEMPORARY
PENSION**

TITLE OF THE INSTRUMENT: Order granting death benefits and orphan's temporary pension

INITIATOR OF THE PROCEDURE: Applicant

INITIATING ENTITY: Pensions Service

PLACE OF SUBMISSION OF FILE: Base unit

REFERENCE INSTRUMENTS:

- Law No. 67/LF/9 of 12 June 1967 on the general organisation of Defence;
- Law No. 80/12 of 14 July 1980 on general rules and regulations governing servicemen, together with all the amendments thereto;
- Decree No. 76/460 of 12 October 1976 to organise military pension schemes based on longevity of service and invalidity pensions, as amended by Decree No. 86/262 of 26 March 1986;
- Decree No. 78/488 of 09 November 1978 defining the terms and conditions for granting civilian and military pensions, life annuities, death grants and death compensation;
- Decree No. 80/257 of 15 July 1980 to lay down general rules and regulations governing the remuneration schemes applicable to military personnel of the Armed Forces, as amended by Decree No. 84/926 of 30 July 1984;
- Decree No. 82/341 of 09 August 1982 to lay down the conditions for granting death benefits;
- Decree No. 85/1092 of 02 August 1985 revalorising civilian and military pensions;
- Decree No. 2001/178 of 25 July 2001 on the general organisation of Defence and Central Staff;
- Decree No. 2001/219 of 06 August 2001 to lay down special rules and regulations governing non-commissioned officers of the Defence Forces;
- Decree No. 2004/056 of 23 March 2004 to organise the mobilisable reserve of non-commissioned officers of the Defence Forces;
- Decree No. 2008/099 of 07 March 2008 to revalorise the basic monthly salaries of civilian and military personnel;
- Decree No. 2008/311 of 27 August 2008 granting an annuity bonus to some military personnel of the Defence Forces;
- Decree No. 2010/382 of 22 December 2010 to amend Decree No. 2001/219 of 06 August 2001 to lay down special rules and regulations governing non-commissioned officers of the Defence Forces;
- Decree No. 2011/412 of 09 December 2011 to reorganise the Presidency of the Republic;
- Decree No. 2014/253 of 07 July 2014 to revalorise the basic monthly salaries of civilian and military personnel;
- Decree No. 2015/194 of 20 April 2015 granting an annuity bonus to some military personnel of the Defence Forces;
- Decree No. 2016/034 of 21 January 2016 to revalorise family allowances;
- Decree No. 2018/190 of 02 March 2018 amending and supplementing certain provisions of Decree No. 2011/408 of 09 December 2011 to organise the Government;
- Decree No. 2019/002 of 04 January 2019 to reshuffle the Government;
- Order No. 236/CAB/PR of 09 November 1978 laying down the procedure for granting civilian and military pensions, life annuities, death grants and death compensation.

REQUIREMENT: Be the minor orphan of an unmarried non-commissioned service member parent who died in active service.

CONSTITUTION OF FILE:

• **Required documents:**

- stamped application on *papier ministre* (ledger square paper) addressed to the Minister;
- copy of death certificate of the service member (established at the council of the place of death);
- photocopy of guardianship judgement;
- certified photocopy of non-appeal certificate;
- guardian's certificate of residence;
- certified copy of guardian's valid national identity card;
- certified photocopies of his/her children's birth certificates (in the case of a recognised child, the page bearing the mention of recognition must be certified);
- collective life certificate of all the children;
- original copies of school certificates of minor children for the current year;
- payslip for the month in which the service member died;
- null payslip of the deceased service member;
- certificate of individuality (where applicable);
- certificate of monogamy or polygamy;
- attestation de non divorce, non séparation et de non remariage certificate of celibacy of the deceased service member;
- military service record of the deceased service member;
- copies of marriage and death certificates of the spouse;
- photocopy of inheritance judgement;
- photocopy of non-appeal certificate of the inheritance judgement;
- Unit Commander's report on the circumstances of the death (where applicable);
- certificate of conformity of date of birth (where applicable);
- copy of Ministerial Decision or Order on invalidity (where applicable).

• **Reference documents:** Staff file

DEADLINE: Sixty (60) days

SIGNATORY OF THE INSTRUMENT: the Minister

DELIVERY METHOD: Collection

QUALITY SUPERVISOR: the Director of Administrative and Regulatory Affairs

PROCESSING: cf. **processing chain:** PROCEDURE No. 01/MINDEF/DAAR/PNO/I
GRANTING A RETIREMENT PENSION

PROCEDURE No. 38/MINDEF/DAAR/PNO/I
**GRANTING OF DEATH BENEFITS, ORPHAN'S TEMPORARY
PENSION AND REVERSION OF A LIFE-LONG INVALIDITY
PENSION**

TITLE OF THE INSTRUMENT: Order on the granting of death benefits, orphan's temporary pension and reversion of a life-long invalidity pension

INITIATOR OF THE PROCEDURE: Applicant

INITIATING ENTITY: Pensions Service

PLACE OF SUBMISSION OF FILE: Base unit

REFERENCE INSTRUMENTS:

- Law No. 67/LF/9 of 12 June 1967 on the general organisation of Defence;
- Law No. 80/12 of 14 July 1980 on general rules and regulations governing servicemen, together with all the amendments thereto;
- Decree No. 76/460 of 12 October 1976 to organise military pension schemes based on longevity of service and invalidity pensions, as amended by Decree No. 86/262 of 26 March 1986;
- Decree No. 78/488 of 09 November 1978 defining the terms and conditions for granting civilian and military pensions, life annuities, death grants and death compensation;
- Decree No. 80/257 of 15 July 1980 to lay down general rules and regulations governing the remuneration schemes applicable to military personnel of the Armed Forces, as amended by Decree No. 84/926 of 30 July 1984;
- Decree No. 82/341 of 09 August 1982 to lay down the conditions for granting death benefits;
- Decree No. 85/1092 of 02 August 1985 revalorising civilian and military pensions;
- Decree No. 2001/178 of 25 July 2001 on the general organisation of Defence and Central Staff;
- Decree No. 2001/219 of 06 August 2001 to lay down special rules and regulations governing non-commissioned officers of the Defence Forces;
- Decree No. 2004/056 of 23 March 2004 to organise the mobilisable reserve of non-commissioned officers of the Defence Forces;
- Decree No. 2008/099 of 07 March 2008 to revalorise the basic monthly salaries of civilian and military personnel;
- Decree No. 2008/311 of 27 August 2008 granting an annuity bonus to some military personnel of the Defence Forces;
- Decree No. 2010/382 of 22 December 2010 to amend Decree No. 2001/219 of 06 August 2001 to lay down special rules and regulations governing non-commissioned officers of the Defence Forces;
- Decree No. 2011/412 of 09 December 2011 to reorganise the Presidency of the Republic;
- Decree No. 2014/253 of 07 July 2014 to revalorise the basic monthly salaries of civilian and military personnel;
- Decree No. 2015/194 of 20 April 2015 granting an annuity bonus to some military personnel of the Defence Forces;
- Decree No. 2016/034 of 21 January 2016 to revalorise family allowances;
- Decree No. 2018/190 of 02 March 2018 amending and supplementing certain provisions of Decree No. 2011/408 of 09 December 2011 to organise the Government;
- Decree No. 2019/002 of 04 January 2019 to reshuffle the Government;
- Order No. 236/CAB/PR of 09 November 1978 laying down the procedure for granting civilian and military pensions, life annuities, death grants and death compensation.

REQUIREMENT: Be the minor orphan of a non-commissioned service member parent who died in active service and was entitled to an invalidity pension.

CONSTITUTION OF FILE:

- **Required documents:**
 - stamped application on *papier ministre* (ledger square paper) addressed to the Minister;
 - copy of death certificate of the service member (established at the council of the place of death);
 - photocopy of guardianship judgement;
 - certified photocopy of non-appeal certificate;
 - guardian's certificate of residence;
 - certified copy of guardian's valid national identity card;
 - certified photocopies of his/her children's birth certificates (in the case of a recognised child, the page bearing the mention of recognition must be certified);
 - collective life certificate of all the children;
 - original copies of school certificates of minor children for the current year;
 - certificate of monogamy or polygamy;
 - certificates of non-divorce, non-separation and non-remarriage;
 - null payslip of the deceased service member;
 - payslip for the month in which the service member died;
 - order granting invalidity pension or copy of the Ministerial Decision on the invalidity of some personnel of the Defence Forces;
 - certificate of celibacy of the deceased service member;
 - military service record of the deceased service member;
 - copies of marriage and death certificates of the spouse;
 - photocopy of inheritance judgement;
 - photocopy of non-appeal certificate of the inheritance judgement;
 - certificate of conformity of date of birth (where applicable);
 - Unit Commander's report on the circumstances of the death (where applicable);
 - certificate of individuality (where applicable);
 - military service record (signed at the unit);
 - invalidity pension payslip (where applicable);
 - Decree granting a retirement pension (where applicable).
- **Reference documents:** Staff file

DEADLINE: Sixty (60) days

SIGNATORY OF THE INSTRUMENT: the Minister

DELIVERY METHOD: Collection

QUALITY SUPERVISOR: the Director of Administrative and Regulatory Affairs

PROCESSING: cf. **processing chain: PROCEDURE No. 01/MINDEF/DAAR/PNO/I**
GRANTING A RETIREMENT PENSION

PROCEDURE No. 39/MINDEF/DAAR/PNO/I
GRANTING A REVERSIONARY PENSION

TITLE OF THE INSTRUMENT: Order granting a reversionary pension

INITIATOR OF THE PROCEDURE: Applicant

INITIATING ENTITY: Pensions Service

PLACE OF SUBMISSION OF FILE: Base unit

REFERENCE INSTRUMENTS:

- Law No. 67/LF/9 of 12 June 1967 on the general organisation of Defence;
- Law No. 80/12 of 14 July 1980 on general rules and regulations governing servicemen, together with all the amendments thereto;
- Decree No. 76/460 of 12 October 1976 to organise military pension schemes based on longevity of service and invalidity pensions, as amended by Decree No. 86/262 of 26 March 1986;
- Decree No. 78/488 of 09 November 1978 defining the terms and conditions for granting civilian and military pensions, life annuities, death grants and death compensation;
- Decree No. 80/257 of 15 July 1980 to lay down general rules and regulations governing the remuneration schemes applicable to military personnel of the Armed Forces, as amended by Decree No. 84/926 of 30 July 1984;
- Decree No. 82/341 of 09 August 1982 to lay down the conditions for granting death benefits;
- Decree No. 85/1092 of 02 August 1985 revalorising civilian and military pensions;
- Decree No. 2001/178 of 25 July 2001 on the general organisation of Defence and Central Staff;
- Decree No. 2001/219 of 06 August 2001 to lay down special rules and regulations governing non-commissioned officers of the Defence Forces;
- Decree No. 2004/056 of 23 March 2004 to organise the mobilisable reserve of non-commissioned officers of the Defence Forces;
- Decree No. 2008/099 of 07 March 2008 to revalorise the basic monthly salaries of civilian and military personnel;
- Decree No. 2008/311 of 27 August 2008 granting an annuity bonus to some military personnel of the Defence Forces;
- Decree No. 2010/382 of 22 December 2010 to amend Decree No. 2001/219 of 06 August 2001 to lay down special rules and regulations governing non-commissioned officers of the Defence Forces;
- Decree No. 2011/412 of 09 December 2011 to reorganise the Presidency of the Republic;
- Decree No. 2014/253 of 07 July 2014 to revalorise the basic monthly salaries of civilian and military personnel;
- Decree No. 2015/194 of 20 April 2015 granting an annuity bonus to some military personnel of the Defence Forces;
- Decree No. 2016/034 of 21 January 2016 to revalorise family allowances;
- Decree No. 2018/190 of 02 March 2018 amending and supplementing certain provisions of Decree No. 2011/408 of 09 December 2011 to organise the Government;
- Decree No. 2019/002 of 04 January 2019 to reshuffle the Government;
- Order No. 236/CAB/PR of 09 November 1978 laying down the procedure for granting civilian and military pensions, life annuities, death grants and death compensation.

REQUIREMENT: Be the widower/widow(s) of a deceased non-commissioned service member pensioner.

CONSTITUTION OF FILE:

• **Required documents:**

- stamped application on *papier ministre* (ledger square paper) addressed to the Minister;
- certified copy of the spouse's valid national identity card;
- certificate of residence;
- copy(ies) of marriage certificate(s);
- certificate of monogamy or polygamy;
- certificate(s) of non-divorce, non-separation and non-remarriage;
- certificates of non-remarriage and non-cohabitation;
- certified photocopies of his/her children's birth certificates (in the case of a recognised child, the page bearing the mention of recognition must be certified);
- collective life certificate of all the children;
- copy of death certificate of the service member (established at the council of the place of death);
- original copies of school certificates of minor children for the current year;
- payslip for the month in which the service member died;
- null payslip of the deceased service member;
- photocopy of inheritance judgement;
- photocopy of non-appeal certificate of the inheritance judgement;
- certificate of individuality (where applicable);
- certificate of conformity of date of birth (where applicable);
- Order granting a retirement pension (where applicable).

• **Reference document:** Staff file

DEADLINE: Sixty (60) days

SIGNATORY OF THE INSTRUMENT: the Minister

DELIVERY METHOD: Collection

QUALITY SUPERVISOR: the Director of Administrative and Regulatory Affairs

PROCESSING: cf. **processing chain:** PROCEDURE No. 01/MINDEF/DAAR/PNO/I
GRANTING A RETIREMENT PENSION

PROCEDURE No. 40/MINDEF/DAAR/PNO/I
**GRANTING AND REVERSION OF A LIFE-LONG INVALIDITY
PENSION**

TITLE OF THE INSTRUMENT: Order on the granting and reversion of a life-long invalidity pension

INITIATOR OF THE PROCEDURE: Applicant

INITIATING ENTITY: Pensions Service

PLACE OF SUBMISSION OF FILE: Base unit

REFERENCE INSTRUMENTS:

- Law No. 67/LF/9 of 12 June 1967 on the general organisation of Defence;
- Law No. 80/12 of 14 July 1980 on general rules and regulations governing servicemen, together with all the amendments thereto;
- Decree No. 76/460 of 12 October 1976 to organise military pension schemes based on longevity of service and invalidity pensions, as amended by Decree No. 86/262 of 26 March 1986;
- Decree No. 78/488 of 09 November 1978 defining the terms and conditions for granting civilian and military pensions, life annuities, death grants and death compensation;
- Decree No. 80/257 of 15 July 1980 to lay down general rules and regulations governing the remuneration schemes applicable to military personnel of the Armed Forces, as amended by Decree No. 84/926 of 30 July 1984;
- Decree No. 82/341 of 09 August 1982 to lay down the conditions for granting death benefits;
- Decree No. 85/1092 of 02 August 1985 revalorising civilian and military pensions;
- Decree No. 2001/178 of 25 July 2001 on the general organisation of Defence and Central Staff;
- Decree No. 2001/219 of 06 August 2001 to lay down special rules and regulations governing non-commissioned officers of the Defence Forces;
- Decree No. 2004/056 of 23 March 2004 to organise the mobilisable reserve of non-commissioned officers of the Defence Forces;
- Decree No. 2008/099 of 07 March 2008 to revalorise the basic monthly salaries of civilian and military personnel;
- Decree No. 2008/311 of 27 August 2008 granting an annuity bonus to some military personnel of the Defence Forces;
- Decree No. 2010/382 of 22 December 2010 to amend Decree No. 2001/219 of 06 August 2001 to lay down special rules and regulations governing non-commissioned officers of the Defence Forces;
- Decree No. 2011/412 of 09 December 2011 to reorganise the Presidency of the Republic;
- Decree No. 2014/253 of 07 July 2014 to revalorise the basic monthly salaries of civilian and military personnel;
- Decree No. 2015/194 of 20 April 2015 granting an annuity bonus to some military personnel of the Defence Forces;
- Decree No. 2016/034 of 21 January 2016 to revalorise family allowances;
- Decree No. 2018/190 of 02 March 2018 amending and supplementing certain provisions of Decree No. 2011/408 of 09 December 2011 to organise the Government;
- Decree No. 2019/002 of 04 January 2019 to reshuffle the Government;
- Order No. 236/CAB/PR of 09 November 1978 laying down the procedure for granting civilian and military pensions, life annuities, death grants and death compensation.

REQUIREMENT: Be the widower/widow(s) of a deceased non-commissioned service member who was entitled to an invalidity pension.

CONSTITUTION OF FILE:

- **Required documents:**
 - stamped application on *papier ministre* (ledger square paper) addressed to the Minister;
 - certified copy of the spouse's valid national identity card;
 - certificate of residence;
 - copy(ies) of marriage certificate(s);
 - certificate of monogamy or polygamy;
 - certificate(s) of non-divorce, non-separation and non-remarriage;
 - certificates of non-remarriage and non-cohabitation;
 - certified photocopies of his/her children's birth certificates (in the case of a recognised child, the page bearing the mention of recognition must be certified);
 - collective life certificate of all the children;
 - copy of death certificate of the service member (established at the council of the place of death);
 - original copies of school certificates of minor children for the current year;
 - Ministerial Decision on the invalidity of some personnel of the Defence Forces;
 - payslip for the month in which the service member died;
 - null payslip of the deceased service member;
 - photocopy of inheritance judgement;
 - photocopy of non-appeal certificate of the inheritance judgement;
 - certificate of individuality (where applicable);
 - certificate of conformity of date of birth (where applicable);
 - Decree granting a retirement pension (where applicable).

- **Reference document:** Staff file

DEADLINE: Sixty (60) days

SIGNATORY OF THE INSTRUMENT: the Minister

DELIVERY METHOD: Collection

QUALITY SUPERVISOR: the Director of Administrative and Regulatory Affairs

PROCESSING: cf. **processing chain:** PROCEDURE No. 01/MINDEF/DAAR/PNO/I
GRANTING A RETIREMENT PENSION

PROCEDURE No. 41/MINDEF/DAAR/PNO/I
GRANTING DEATH BENEFITS AND SURVIVOR'S PENSION

TITLE OF THE INSTRUMENT: Order granting death benefits and survivor's pension

INITIATOR OF THE PROCEDURE: Applicant

INITIATING ENTITY: Pensions Service

PLACE OF SUBMISSION OF FILE: Base unit

REFERENCE INSTRUMENTS:

- Law No. 67/LF/9 of 12 June 1967 on the general organisation of Defence;
- Law No. 80/12 of 14 July 1980 on general rules and regulations governing servicemen, together with all the amendments thereto;
- Decree No. 76/460 of 12 October 1976 to organise military pension schemes based on longevity of service and invalidity pensions, as amended by Decree No. 86/262 of 26 March 1986;
- Decree No. 78/488 of 09 November 1978 defining the terms and conditions for granting civilian and military pensions, life annuities, death grants and death compensation;
- Decree No. 80/257 of 15 July 1980 to lay down general rules and regulations governing the remuneration schemes applicable to military personnel of the Armed Forces, as amended by Decree No. 84/926 of 30 July 1984;
- Decree No. 82/341 of 09 August 1982 to lay down the conditions for granting death benefits;
- Decree No. 85/1092 of 02 August 1985 revalorising civilian and military pensions;
- Decree No. 2001/178 of 25 July 2001 on the general organisation of Defence and Central Staff;
- Decree No. 2001/219 of 06 August 2001 to lay down special rules and regulations governing non-commissioned officers of the Defence Forces;
- Decree No. 2004/056 of 23 March 2004 to organise the mobilisable reserve of non-commissioned officers of the Defence Forces;
- Decree No. 2008/099 of 07 March 2008 to revalorise the basic monthly salaries of civilian and military personnel;
- Decree No. 2008/311 of 27 August 2008 granting an annuity bonus to some military personnel of the Defence Forces;
- Decree No. 2010/382 of 22 December 2010 to amend Decree No. 2001/219 of 06 August 2001 to lay down special rules and regulations governing non-commissioned officers of the Defence Forces;
- Decree No. 2011/412 of 09 December 2011 to reorganise the Presidency of the Republic;
- Decree No. 2014/253 of 07 July 2014 to revalorise the basic monthly salaries of civilian and military personnel;
- Decree No. 2015/194 of 20 April 2015 granting an annuity bonus to some military personnel of the Defence Forces;
- Decree No. 2016/034 of 21 January 2016 to revalorise family allowances;
- Decree No. 2018/190 of 02 March 2018 amending and supplementing certain provisions of Decree No. 2011/408 of 09 December 2011 to organise the Government;
- Decree No. 2019/002 of 04 January 2019 to reshuffle the Government;
- Order No. 236/CAB/PR of 09 November 1978 laying down the procedure for granting civilian and military pensions, life annuities, death grants and death compensation.

REQUIREMENTS:

- be a father (above 60 years) or mother (above 55 years) of an unmarried and childless non-commissioned service member who died in active service;
- not be subject to personal income tax.

CONSTITUTION OF FILE:

• **Required documents:**

- stamped application on *papier ministre* (ledger square paper) addressed to the Minister;
- copy of death certificate of the service member (established at the council of the place of death);
- certified photocopy of the survivor's valid national identity card (father above 60 years or mother above 55 years or any disabled or invalid parent regardless of age);
- military service record of the deceased service member;
- photocopy of the inheritance judgement;
- certified copy of non-appeal certificate of the inheritance judgement;
- certificate of celibacy of the deceased;
- certificate of residence of the applicant parent;
- certified copy of birth certificate of the deceased;
- payslip for the month in which the service member died;
- null payslip;
- certificate of unemployment;
- Unit Commander's report on the circumstances of the death (where applicable);
- individual life certificate of the applicant parent;
- certificate of individuality (where applicable);
- certificate of conformity of date of birth (where applicable).

• **Reference document:** Staff file

DEADLINE: Sixty (60) days

SIGNATORY OF THE INSTRUMENT: the Minister

DELIVERY METHOD: Collection

QUALITY SUPERVISOR: the Director of Administrative and Regulatory Affairs

PROCESSING: cf. processing chain: PROCEDURE No. 01/MINDEF/DAAR/PNO/I
GRANTING A RETIREMENT PENSION

PROCEDURE No. 42/MINDEF/DAAR/PNO/I
REIMBURSEMENT OF PENSION DEDUCTIONS

TITLE OF THE INSTRUMENT: Order reimbursing pension deductions

INITIATOR OF THE PROCEDURE: Applicant

INITIATING ENTITY: Pensions Service

PLACE OF SUBMISSION OF FILE: Base unit

REFERENCE INSTRUMENTS:

- Law No. 67/LF/9 of 12 June 1967 on the general organisation of Defence;
- Law No. 80/12 of 14 July 1980 on general rules and regulations governing servicemen, together with all the amendments thereto;
- Decree No. 76/460 of 12 October 1976 to organise military pension schemes based on longevity of service and invalidity pensions, as amended by Decree No. 86/262 of 26 March 1986;
- Decree No. 78/488 of 09 November 1978 defining the terms and conditions for granting civilian and military pensions, life annuities, death grants and death compensation;
- Decree No. 80/257 of 15 July 1980 to lay down general rules and regulations governing the remuneration schemes applicable to military personnel of the Armed Forces, as amended by Decree No. 84/926 of 30 July 1984;
- Decree No. 82/341 of 09 August 1982 to lay down the conditions for granting death benefits;
- Decree No. 85/1092 of 02 August 1985 revalorising civilian and military pensions;
- Decree No. 2001/178 of 25 July 2001 on the general organisation of Defence and Central Staff;
- Decree No. 2001/219 of 06 August 2001 to lay down special rules and regulations governing non-commissioned officers of the Defence Forces;
- Decree No. 2004/056 of 23 March 2004 to organise the mobilisable reserve of non-commissioned officers of the Defence Forces;
- Decree No. 2008/099 of 07 March 2008 to revalorise the basic monthly salaries of civilian and military personnel;
- Decree No. 2008/311 of 27 August 2008 granting an annuity bonus to some military personnel of the Defence Forces;
- Decree No. 2010/382 of 22 December 2010 to amend Decree No. 2001/219 of 06 August 2001 to lay down special rules and regulations governing non-commissioned officers of the Defence Forces;
- Decree No. 2011/412 of 09 December 2011 to reorganise the Presidency of the Republic;
- Decree No. 2014/253 of 07 July 2014 to revalorise the basic monthly salaries of civilian and military personnel;
- Decree No. 2015/194 of 20 April 2015 granting an annuity bonus to some military personnel of the Defence Forces;
- Decree No. 2016/034 of 21 January 2016 to revalorise family allowances;
- Decree No. 2018/190 of 02 March 2018 amending and supplementing certain provisions of Decree No. 2011/408 of 09 December 2011 to organise the Government;
- Decree No. 2019/002 of 04 January 2019 to reshuffle the Government;
- Order No. 236/CAB/PR of 09 November 1978 laying down the procedure for granting civilian and military pensions, life annuities, death grants and death compensation.

REQUIREMENT: Be a non-commissioned service member dismissed/discharged before having completed 15 years of effective service.

CONSTITUTION OF FILE:

- **Required documents:**
 - stamped application on *papier ministre* (ledger square paper) addressed to the Minister;
 - certified copy of valid national identity card;
 - military service record of the deceased service member;
 - ministerial decision to strike off staff;
 - recent payslip;
 - certificate of residence;
 - certificate of individuality (where applicable);
 - certificate of conformity of date of birth (where applicable).
- **Reference documents:** Staff file

DEADLINE: Sixty (60) days

SIGNATORY OF THE INSTRUMENT: the Minister

DELIVERY METHOD: Collection

QUALITY SUPERVISOR: the Director of Administrative and Regulatory Affairs

PROCESSING: cf. **processing chain:** PROCEDURE No. 01/MINDEF/DAAR/PNO/I
GRANTING A RETIREMENT PENSION

PROCEDURE No. 43/MINDEF/DAAR/PNO/I
**AUTHORISING PAYMENT OF PENSION AND REIMBURSEMENT
OF PENSION DEDUCTIONS**

TITLE OF THE INSTRUMENT: Order authorising payment of pension and reimbursement of pension deductions

INITIATOR OF THE PROCEDURE: Applicant

INITIATING ENTITY: Pensions Service

PLACE OF SUBMISSION OF FILE: Base unit

REFERENCE INSTRUMENTS:

- Law No. 67/LF/9 of 12 June 1967 on the general organisation of Defence;
- Law No. 80/12 of 14 July 1980 on general rules and regulations governing servicemen, together with all the amendments thereto;
- Decree No. 76/460 of 12 October 1976 to organise military pension schemes based on longevity of service and invalidity pensions, as amended by Decree No. 86/262 of 26 March 1986;
- Decree No. 78/488 of 09 November 1978 defining the terms and conditions for granting civilian and military pensions, life annuities, death grants and death compensation;
- Decree No. 80/257 of 15 July 1980 to lay down general rules and regulations governing the remuneration schemes applicable to military personnel of the Armed Forces, as amended by Decree No. 84/926 of 30 July 1984;
- Decree No. 82/341 of 09 August 1982 to lay down the conditions for granting death benefits;
- Decree No. 85/1092 of 02 August 1985 revalorising civilian and military pensions;
- Decree No. 2001/178 of 25 July 2001 on the general organisation of Defence and Central Staff;
- Decree No. 2001/219 of 06 August 2001 to lay down special rules and regulations governing non-commissioned officers of the Defence Forces;
- Decree No. 2004/056 of 23 March 2004 to organise the mobilisable reserve of non-commissioned officers of the Defence Forces;
- Decree No. 2008/099 of 07 March 2008 to revalorise the basic monthly salaries of civilian and military personnel;
- Decree No. 2008/311 of 27 August 2008 granting an annuity bonus to some military personnel of the Defence Forces;
- Decree No. 2010/382 of 22 December 2010 to amend Decree No. 2001/219 of 06 August 2001 to lay down special rules and regulations governing non-commissioned officers of the Defence Forces;
- Decree No. 2011/412 of 09 December 2011 to reorganise the Presidency of the Republic;
- Decree No. 2014/253 of 07 July 2014 to revalorise the basic monthly salaries of civilian and military personnel;
- Decree No. 2015/194 of 20 April 2015 granting an annuity bonus to some military personnel of the Defence Forces;
- Decree No. 2016/034 of 21 January 2016 to revalorise family allowances;
- Decree No. 2018/190 of 02 March 2018 amending and supplementing certain provisions of Decree No. 2011/408 of 09 December 2011 to organise the Government;
- Decree No. 2019/002 of 04 January 2019 to reshuffle the Government;
- Order No. 236/CAB/PR of 09 November 1978 laying down the procedure for granting civilian and military pensions, life annuities, death grants and death compensation.

REQUIREMENT: Be a non-commissioned service member with at least 03 years of service who has been struck off or discharged for non-disciplinary reasons.

CONSTITUTION OF FILE:

- **Required documents:**
 - stamped application on *papier ministre* (ledger square paper) addressed to the Minister;
 - certified copy of valid national identity card;
 - military service record of the deceased service member;
 - ministerial decision to strike off staff;
 - certificate of residence;
 - recent payslip;
 - certificate of individuality (where applicable);
 - certificate of conformity of date of birth (where applicable).
- **Reference documents:** Staff file

DEADLINE: Sixty (60) days

SIGNATORY OF THE INSTRUMENT: the Minister

DELIVERY METHOD: Collection

QUALITY SUPERVISOR: the Director of Administrative and Regulatory Affairs

PROCESSING: cf. processing chain: PROCEDURE No. 01/MINDEF/DAAR/PNO/I
GRANTING A RETIREMENT PENSION

**PROCEDURE No. 44/MINDEF/DAAR/PNO/I
GRANTING DEATH BENEFITS**

TITLE OF THE INSTRUMENT: Order granting death benefits

INITIATOR OF THE PROCEDURE: Applicant

INITIATING ENTITY: Pensions Service

PLACE OF SUBMISSION OF FILE: Base unit

REFERENCE INSTRUMENTS:

- Law No. 67/LF/9 of 12 June 1967 on the general organisation of Defence;
- Law No. 80/12 of 14 July 1980 on general rules and regulations governing servicemen, together with all the amendments thereto;
- Decree No. 76/460 of 12 October 1976 to organise military pension schemes based on longevity of service and invalidity pensions, as amended by Decree No. 86/262 of 26 March 1986;
- Decree No. 78/488 of 09 November 1978 defining the terms and conditions for granting civilian and military pensions, life annuities, death grants and death compensation;
- Decree No. 80/257 of 15 July 1980 to lay down general rules and regulations governing the remuneration schemes applicable to military personnel of the Armed Forces, as amended by Decree No. 84/926 of 30 July 1984;
- Decree No. 82/341 of 09 August 1982 to lay down the conditions for granting death benefits;
- Decree No. 85/1092 of 02 August 1985 revalorising civilian and military pensions;
- Decree No. 2001/178 of 25 July 2001 on the general organisation of Defence and Central Staff;
- Decree No. 2001/219 of 06 August 2001 to lay down special rules and regulations governing non-commissioned officers of the Defence Forces;
- Decree No. 2004/056 of 23 March 2004 to organise the mobilisable reserve of non-commissioned officers of the Defence Forces;
- Decree No. 2008/099 of 07 March 2008 to revalorise the basic monthly salaries of civilian and military personnel;
- Decree No. 2008/311 of 27 August 2008 granting an annuity bonus to some military personnel of the Defence Forces;
- Decree No. 2010/382 of 22 December 2010 to amend Decree No. 2001/219 of 06 August 2001 to lay down special rules and regulations governing non-commissioned officers of the Defence Forces;
- Decree No. 2011/412 of 09 December 2011 to reorganise the Presidency of the Republic;
- Decree No. 2014/253 of 07 July 2014 to revalorise the basic monthly salaries of civilian and military personnel;
- Decree No. 2015/194 of 20 April 2015 granting an annuity bonus to some military personnel of the Defence Forces;
- Decree No. 2016/034 of 21 January 2016 to revalorise family allowances;
- Decree No. 2018/190 of 02 March 2018 amending and supplementing certain provisions of Decree No. 2011/408 of 09 December 2011 to organise the Government;
- Decree No. 2019/002 of 04 January 2019 to reshuffle the Government;
- Order No. 236/CAB/PR of 09 November 1978 laying down the procedure for granting civilian and military pensions, life annuities, death grants and death compensation.

REQUIREMENT: Be the heir of a non-commissioned service member who died in active service.

CONSTITUTION OF FILE:

- **Required documents:**
 - stamped application on *papier ministre* (ledger square paper) addressed to the Minister;
 - recent payslip;
 - certified copy of valid national identity card;
 - military service record of the deceased service member;
 - certificate of residence;
 - inheritance judgement;
 - medical certificate indicating the nature of death;
 - Unit Commander's report on the circumstances of the death (where applicable);
 - certificate of individuality (where applicable);
 - certificate of conformity of date of birth (where applicable).
- **Reference document:** Staff file

DEADLINE: Sixty (60) days

SIGNATORY OF THE INSTRUMENT: the Minister

DELIVERY METHOD: Collection

QUALITY SUPERVISOR: the Director of Administrative and Regulatory Affairs

PROCESSING: cf. **processing chain:** PROCEDURE No. 01/MINDEF/DAAR/PNO/I
GRANTING A RETIREMENT PENSION

VOLUME 5
**RECRUITMENT OF MILITARY
PERSONNEL**

RECRUITMENT PROCEDURES

1. LAUNCHING RECRUITMENT INTO THE DEFENCE FORCES
2. TEMPORARY ENLISTMENT OF A NON-COMMISSIONED SERVICE MEMBER
3. SPECIAL ENLISTMENT OF AN OFFICER

PROCEDURE No. 01/MINDEF/DRH/I
LAUNCHING RECRUITMENT INTO THE DEFENCE FORCES

TITLE OF THE INSTRUMENT: Press release on the launch of recruitment into the Defence Forces

INITIATOR OF THE PROCEDURE: Administration

INITIATING ENTITY: National Archives, Recruitment, Reserves and Mobilisation Service

REFERENCE INSTRUMENTS:

- Law No. 67/LF/9 of 12 June 1967 on the general organisation of Defence;
- Law No. 80/12 of 14 July 1980 on general rules and regulations governing servicemen, together with all the amendments thereto;
- Decree No. 80/257 of 15 July 1980 to lay down general rules and regulations governing the remuneration schemes applicable to military personnel of the Armed Forces, as amended by Decree No. 84/926 of 30 July 1984;
- Decree No. 2001/178 of 25 July 2001 on the general organisation of Defence and Central Staff;
- Decree No. 2001/188 of 25 July 2001 to lay down special rules and regulations governing the corps of Active Officers of the Defence Forces;
- Decree No. 2001/219 of 06 August 2001 to lay down special rules and regulations governing non-commissioned officers of the Defence Forces;
- Decree No. 2011/408 of 09 December 2011 to organise the Government;
- Decree No. 2011/412 of 09 December 2011 to reorganise the Presidency of the Republic;
- Decree No. 2012/386 of 14 September 2012 amending Decree No. 2001/177 of 25 July 2001 to organise the Ministry of Defence;
- Decree No. 2006/365 of 25 October 2006 amending and supplementing certain provisions of Decree No. 2001/187 of 25 July 2001 to lay down the conditions for admission to **Military Officers' Training Schools**;
- Decree No. 2007/199 of 07 July 2007 to lay down Rules of General Discipline in the Defence Forces;
- Ministerial Instruction DOC - H1 of 1960 on engagements.

REQUIREMENTS: N/A

CONSTITUTION OF FILE:

*** Required documents:**

*** Reference documents:**

- letter of approval from the Presidency of the Republic;
- expression of the needs of the staff.

DEADLINE: Fourteen (14) days

SIGNATORY OF THE INSTRUMENT: the Minister

DELIVERY METHOD: Posting/Publication

QUALITY SUPERVISOR: the Director of Human Resource

PROCESSING

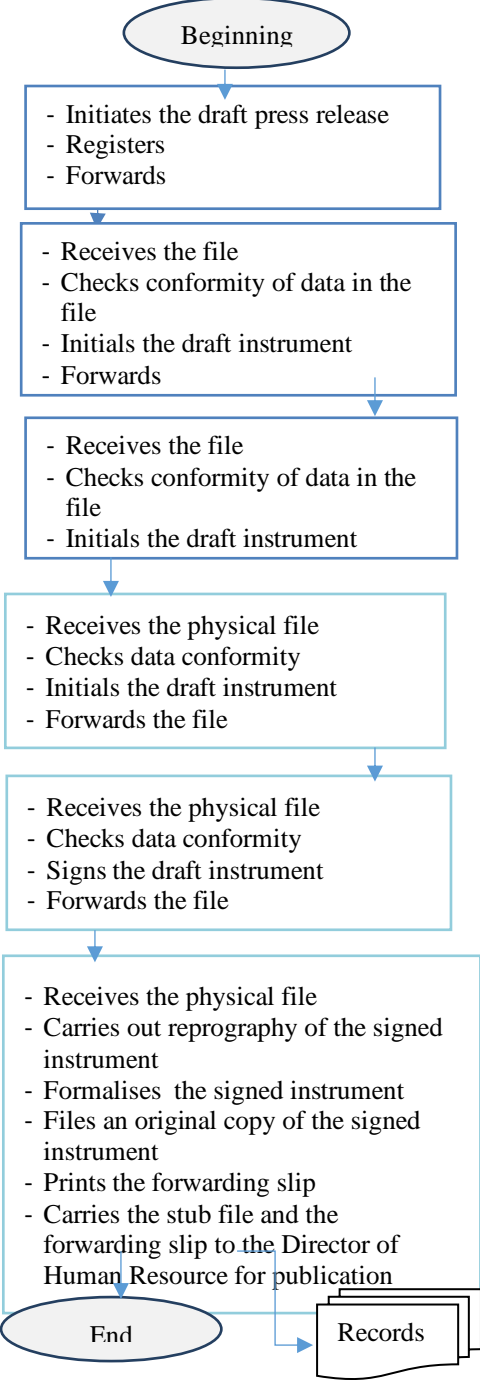
DEPARTMENT OF HUMAN RESOURCE	PROCEDURE No. 1/MINDEF/SED/DRH/I <u>LAUNCHING RECRUITMENT INTO THE DEFENCE FORCES</u>	Deadline	Procedure start date: 2023 Procedure version: 1.0 Page
<i>Intervening parties</i>	<i>Stages</i>		<i>Handling rules</i>
 <ul style="list-style-type: none"> <li data-bbox="245 651 549 725">Head of Recruitment Bureau <li data-bbox="229 797 549 904">Head of National Archives, Recruitment, Reserves and Mobilisation Service <li data-bbox="236 1003 549 1077">Director of Human Resource <li data-bbox="309 1196 520 1256">Secretary General <li data-bbox="300 1361 510 1422">Minister <li data-bbox="245 1576 542 1653">Head of Military Secretariat 	 <pre> graph TD Start([Beginning]) --> S1["- Initiates the draft press release - Registers - Forwards"] S1 --> S2["- Receives the file - Checks conformity of data in the file - Initials the draft instrument - Forwards"] S2 --> S3["- Receives the file - Checks conformity of data in the file - Initials the draft instrument"] S3 --> S4["- Receives the physical file - Checks data conformity - Initials the draft instrument - Forwards the file"] S4 --> S5["- Receives the physical file - Checks data conformity - Signs the draft instrument - Forwards the file"] S5 --> S6["- Receives the physical file - Carries out reprography of the signed instrument - Formalises the signed instrument - Files an original copy of the signed instrument - Prints the forwarding slip - Carries the stub file and the forwarding slip to the Director of Human Resource for publication"] S6 --> End([End]) End --> Records[Records] </pre>		<p>R1: Ensure availability of the letter of approval from the Presidency of the Republic</p>

PROCEDURE No. 02MINDEF/DRH/PNO/1
**TEMPORARY ENLISTMENT OF A NON-COMMISSIONED
SERVICE MEMBER**

TITLE OF THE INSTRUMENT: Temporary enlistment instrument

INITIATOR OF THE PROCEDURE: Administration

INITIATING ENTITY: National Archives, Recruitment, Reserves and Mobilisation Service

REFERENCE INSTRUMENTS:

- Law No. 67/LF/9 of 12 June 1967 on the general organisation of Defence;
- Law No. 80/12 of 14 July 1980 on general rules and regulations governing servicemen, together with all the amendments thereto;
- Decree No. 80/257 of 15 July 1980 to lay down general rules and regulations governing the remuneration schemes applicable to military personnel of the Armed Forces, as amended by Decree No. 84/926 of 30 July 1984;
- Decree No. 2001/178 of 25 July 2001 on the general organisation of Defence and Central Staff;
- Decree No. 2001/219 of 06 August 2001 to lay down special rules and regulations governing non-commissioned officers of the Defence Forces;
- Decree No. 2011/408 of 09 December 2011 to organise the Government;
- Decree No. 2011/412 of 09 December 2011 to reorganise the Presidency of the Republic;
- Decree No. 2012/386 of 14 September 2012 amending Decree No. 2001/177 of 25 July 2001 to organise the Ministry of Defence;
- Decree No. 2006/365 of 25 October 2006 amending and supplementing certain provisions of Decree No. 2001/187 of 25 July 2001 to lay down the conditions for admission to Military Officers' Training Schools;
- Decree No. 2007/199 of 07 July 2007 to lay down Rules of General Discipline in the Defence Forces;
- Ministerial Instruction DOC - H1 of 1960 on engagements.

REQUIREMENTS:

- be of Cameroonian nationality;
- enjoy his/her civic rights;
- fulfil the age requirements for the given level of recruitment;
- have the required certificate;
- be medically fit.

CONSTITUTION OF FILE:

*** Required documents:**

- stamped handwritten application addressed to the Minister;
- certified copy of the certificate entitling the holder;
- attestation of presentation of original of the certificate;
- certified true copy of transcript of the first year of university studies;
- medical certificate duly signed by a military doctor;
- certificate of nationality;
- certificate of celibacy;
- certified true copy of birth certificate;
- curriculum vitae;
- stamped A4 envelope;

- blank cardboard folder;
- information sheet obtained at the Ministry of Defence/Department of Human Resource;
- receipt of payment of competitive examination fees;
- certificate of non-conviction.

* ***Reference documents:***

- press release on the launch of the competitive examination;
- service note and messages.







DEADLINE: Sixty (60) days after publication of the final results of the competitive examination

SIGNATORY OF THE INSTRUMENT: the Minister/Director of Human Resource by Delegation

DELIVERY METHOD: Notification

QUALITY SUPERVISOR: the Director of Human Resource

PROCESSING

DEPARTMENT OF HUMAN RESOURCE		PROCEDURE No. 02 <u>TEMPORARY ENLISTMENT OF A NON-COMMISSIONED SERVICE MEMBER</u>	Deadline	Procedure start date: 2023 Procedure version: 1.0 Page
<i>Intervening parties</i>		<i>Stages</i>		<i>Handling rules</i>
	Head of Recruitment Bureau	<p>Beginning</p> <ul style="list-style-type: none"> - Initiates the draft enlistment instrument - Registers 		<p>R1: Ensure that the file is complete</p> <p>R2: Check legality of procedures</p>
	Head of National Archives, Recruitment, Reserves and Mobilisation Service	<ul style="list-style-type: none"> - Receives the file - Checks conformity of data in the file - Initials the draft instrument - Forwards 		
	Relevant Deputy Director	<ul style="list-style-type: none"> - Receives the file - Checks conformity of data in the file - Initials the draft instrument - Forwards 		
	Director of Human Resource	<ul style="list-style-type: none"> - Receives the physical file - Checks data conformity - Initials the draft instrument - Forwards the file 		
	Secretary General	<ul style="list-style-type: none"> - Receives the physical file - Checks data conformity - Initials the draft instrument - Forwards the file 		
	Minister	<ul style="list-style-type: none"> - Receives the physical file - Checks data conformity - Signs the draft instrument - Forwards the file 		
	Head of Military Secretariat	<ul style="list-style-type: none"> - Receives the physical file - Forwards the file 		

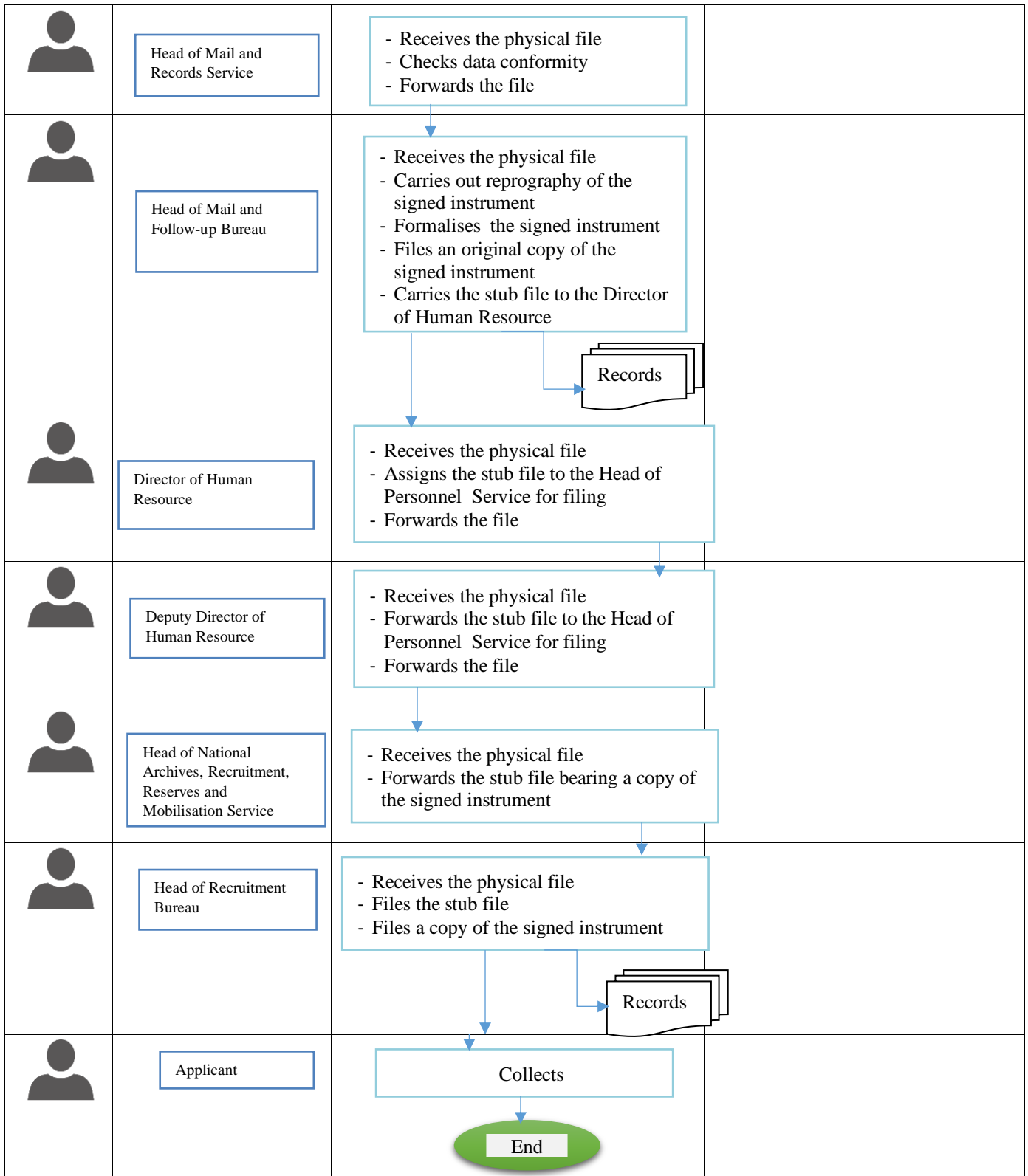

**PROCEDURE No. 03/MINDEF/DRH/PO/1
SPECIAL ENLISTMENT OF AN OFFICER**

TITLE OF THE INSTRUMENT: Special enlistment instrument

INITIATOR OF THE PROCEDURE: Administration

INITIATING ENTITY: National Archives, Recruitment, Reserves and Mobilisation Service

REFERENCE INSTRUMENTS:

- Law No. 67/LF/9 of 12 June 1967 on the general organisation of Defence;
- Law No. 80/12 of 14 July 1980 on general rules and regulations governing servicemen, together with all the amendments thereto;
- Decree No. 80/257 of 15 July 1980 to lay down general rules and regulations governing the remuneration schemes applicable to military personnel of the Armed Forces, as amended by Decree No. 84/926 of 30 July 1984;
- Decree No. 2001/178 of 25 July 2001 on the general organisation of Defence and Central Staff;
- Decree No. 2001/188 of 25 July 2001 to lay down special rules and regulations governing the corps of Active Officers of the Defence Forces;
- Decree No. 2011/408 of 09 December 2011 to organise the Government;
- Decree No. 2011/412 of 09 December 2011 to reorganise the Presidency of the Republic;
- Decree No. 2012/386 of 14 September 2012 amending Decree No. 2001/177 of 25 July 2001 to organise the Ministry of Defence;
- Decree No. 2006/365 of 25 October 2006 amending and supplementing certain provisions of Decree No. 2001/187 of 25 July 2001 to lay down the conditions for admission to Military Officers' Training Schools;
- Decree No. 2007/199 of 07 July 2007 to lay down Rules of General Discipline in the Defence Forces;
- Ministerial Instruction DOC - H1 of 1960 on engagements.

REQUIREMENTS:

- be of Cameroonian nationality;
- enjoy his/her civic rights;
- fulfil the age requirements for the given level of recruitment;
- have the required certificate;
- be medically fit.

CONSTITUTION OF FILE:

*** Required documents:**

- stamped handwritten application addressed to the Minister;
- certified copy of the certificate entitling the holder;
- attestation of presentation of original of the certificate;
- certified true copy of transcript of the first year of university studies;
- medical certificate duly signed by a military doctor;
- certificate of nationality;
- certificate of celibacy;
- certified true copy of birth certificate;
- curriculum vitae;

- stamped A4 envelope;
- blank cardboard folder;
- information sheet obtained at the Ministry of Defence/Department of Human Resource;
- receipt of payment of competitive examination fees;
- certificate of non-conviction.

*** Reference documents:**

- press release on the launch of the competitive examination;
- service note and messages.

DEADLINE: Ninety (90) days after publication of final results of the competitive examination

SIGNATORY OF THE INSTRUMENT: the Minister

DELIVERY METHOD: Notification

QUALITY SUPERVISOR: the Director of Human Resource

**PROCESSING: cf. processing chain: PROCEDURE No. 02
TEMPORARY ENLISTMENT OF A NON-COMMISSIONED SERVICE MEMBER**

VOLUME 6:
ALLOWANCES OF MILITARY
PERSONNEL

PAYMENT PROCEDURES

	OFFICER'S PENSION
1.	GRANTING TECHNICAL ALLOWANCE
2.	GRANTING VEHICLE MAINTENANCE ALLOWANCE
	NON-COMMISSIONED SERVICE PERSONNEL PENSION
3.	GRANTING TECHNICAL ALLOWANCE
4.	GRANTING VEHICLE MAINTENANCE ALLOWANCE
5.	PAYMENT OF NON-ACCOMMODATION ALLOWANCE

OFFICER'S PENSION

**PROCEDURE No. 01/MINDEF/DAAR/PO/I
GRANTING TECHNICAL ALLOWANCE**

TITLE OF THE INSTRUMENT: Order granting technical allowance

INITIATOR OF THE PROCEDURE: Applicant

INITIATING ENTITY: Studies and Regulatory Service

PLACE OF SUBMISSION OF FILE: Base unit

REFERENCE INSTRUMENTS:

- Law No. 67/LF/9 of 12 June 1967 on the general organisation of Defence;
- Law No. 71/LF/3 of 04 June 1971 on rules and regulations governing officers;
- Law No. 80/12 of 14 July 1980 on general rules and regulations governing servicemen, together with all the amendments thereto;
- Decree No. 76/460 of 12 October 1976 to organise military pension schemes based on longevity of service and invalidity pensions, as amended by Decree No. 86/262 of 26 March 1986;
- Decree No. 71/DF of 29 June 1971 fixing the rates and lists of securities, certificates or patents entitled to the technical allowance established by Decree No. 68/DF/270 of 15 July 1968 on the general regulations on remuneration schemes applicable to military personnel of the Armed Forces.
- Decree No. 80/257 of 15 July 1980 to lay down general rules and regulations governing the remuneration schemes applicable to military personnel of the Armed Forces, as amended by Decree No. 84/926 of 30 July 1984;
- Decree No. 2001/178 of 25 July 2001 on the general organisation of Defence and Central Staff;
- Decree No. 2001/188 of 25 July 2001 to lay down special rules and regulations governing the corps of Active Officers of the Defence Forces;
- Decree No. 2018/190 of 02 March 2018 amending and supplementing certain provisions of Decree No. 2011/408 of 09 December 2011 to organise the Government.

REQUIREMENTS:

- be an officer with a technical allowance qualification/certificate;
- have an authorisation for training issued by the Minister of Defence, for military personnel in active service.

CONSTITUTION OF FILE:

• **Required documents:**

- stamped application on *papier ministre* (ledger square paper) addressed to the Minister;
- certified copy of certificate;
- copy of authorisation instrument issued by the Minister of Defence, where applicable.

• **Reference document:** Staff file













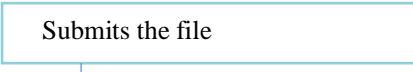

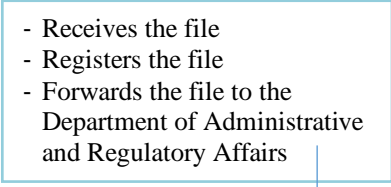
DEADLINE: Sixty (60) days

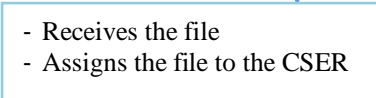
SIGNATORY OF THE INSTRUMENT: the Minister

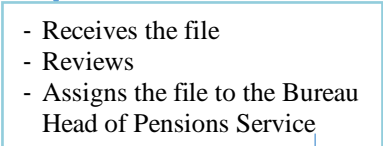
DELIVERY METHOD: Collection

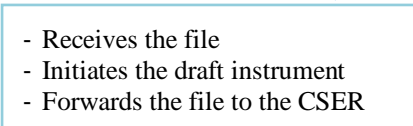
QUALITY SUPERVISOR: the Director of Administrative and Regulatory Affairs

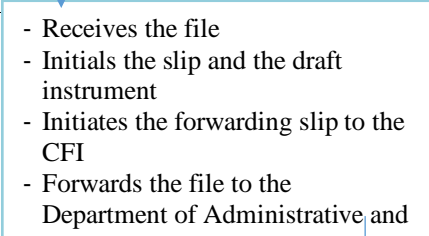
PROCESSING

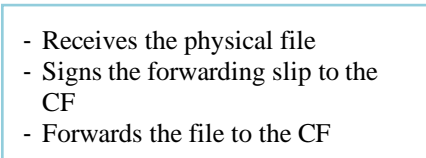
DEPARTMENT OF ADMINISTRATIVE AND REGULATORY AFFAIRS	PROCEDURE No. 01/MINDEF/DAAR/PO/I <u>GRANTING TECHNICAL ALLOWANCE</u>	Procedure start date: 2023	
		Procedure version:	
		Deadline	Page
<i>Intervening parties</i>	<i>Stages</i>		<i>Handling rules</i>
			R1: Check file's compliance
 Applicant			R2: Check the authenticity of information provided
 Base unit			R3: Ensure that the applicant is eligible R4: Ensure procedure consistency
 DAAR			
 CSER			
 CBLR			
 CSER			
 DAAR			
FINANCIAL CONTROLLER			



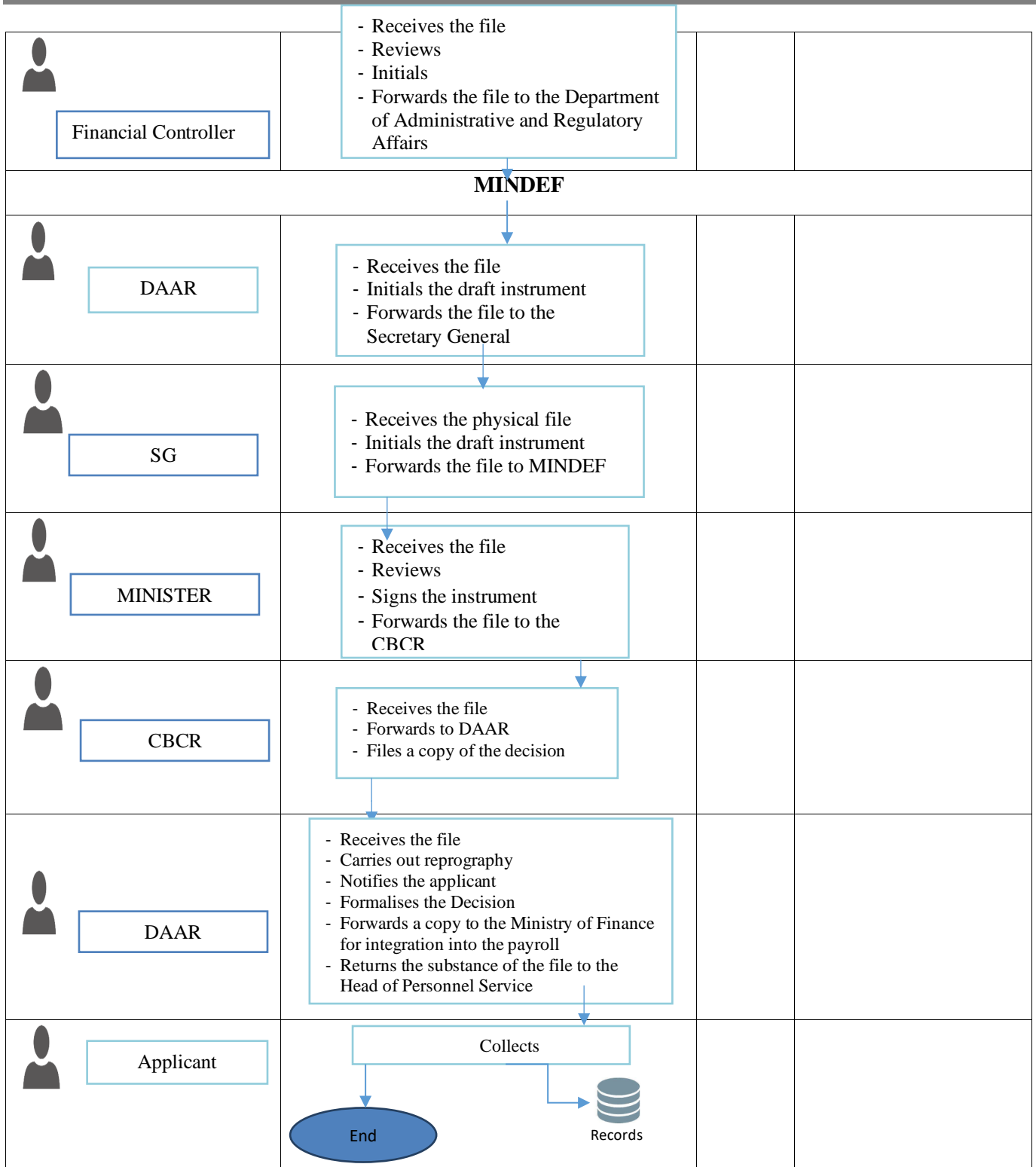

**PROCEDURE No. 02/MINDEF/DAAR/PO/I
GRANTING VEHICLE MAINTENANCE ALLOWANCE**

TITLE OF THE INSTRUMENT: Decision granting vehicle maintenance allowance

INITIATOR OF THE PROCEDURE: Applicant

INITIATING ENTITY: Studies and Regulatory Service

PLACE OF SUBMISSION OF FILE: Base unit

REFERENCE INSTRUMENTS:

- Law No. 67/LF/9 of 12 June 1967 on the general organisation of Defence;
- Law No. 80/12 of 14 July 1980 on general rules and regulations governing servicemen, together with all the amendments thereto;
- Decree No. 76/460 of 12 October 1976 to organise military pension schemes based on longevity of service and invalidity pensions, as amended by Decree No. 86/262 of 26 March 1986;
- Decree No. 80/257 of 15 July 1980 to lay down general rules and regulations governing the remuneration schemes applicable to military personnel of the Armed Forces, as amended by Decree No. 84/926 of 30 July 1984;
- Decree No. 87/1142 of 20 August 1987 regulating the use of military vehicles of the commercial range, the granting of advance to military personnel and agents of the Ministry of Defence for the acquisition of personal vehicles, and the conditions for participation of the State in the expenses of maintenance of the vehicles of some service personnel;
- Decree No. 2001/188 of 25 July 2001 to lay down special rules and regulations governing the corps of Active Officers of the Defence Forces;
- Decree No. 2018/190 of 02 March 2018 amending and supplementing certain provisions of Decree No. 2011/408 of 09 December 2011 to organise the Government.

PLACE OF SUBMISSION OF FILE: SED/CGN and/or Elementary Unit Mail Service

REQUIREMENT: Be an officer using his/her personal vehicle for service purposes.

CONSTITUTION OF FILE:

- **Required documents:**
 - stamped application on *papier ministre* (ledger square paper) addressed to the Minister;
 - copy of vehicle registration document;
 - payslip;
 - confirmatory note from the chief of staff attesting that the owner of the vehicle is using it for service purposes.
- **Reference document:** Staff file

DEADLINE: Sixty (60) days

SIGNATORY OF THE INSTRUMENT: the Minister

DELIVERY METHOD: Collection

QUALITY SUPERVISOR: the Director of Administrative and Regulatory Affairs

**PROCESSING: cf. processing chain: PROCEDURE No. 01/MINDEF/DAAR/PO/I
GRANTING TECHNICAL ALLOWANCE**

**NON-COMMISSIONED SERVICE PERSONNEL
PENSION**

**PROCEDURE No. 03/MINDEF/DAAR/PNO/I
GRANTING TECHNICAL ALLOWANCE**

TITLE OF THE INSTRUMENT: Order granting technical allowance

INITIATOR OF THE PROCEDURE: Applicant

INITIATING ENTITY: Studies and Regulatory Service

PLACE OF SUBMISSION OF FILE: Base unit

REFERENCE INSTRUMENTS:

- Law No. 67/LF/9 of 12 June 1967 on the general organisation of Defence;
- Law No. 71/LF/3 of 04 June 1971 on rules and regulations governing officers;
- Law No. 80/12 of 14 July 1980 on general rules and regulations governing servicemen, together with all the amendments thereto;
- Decree No. 76/460 of 12 October 1976 to organise military pension schemes based on longevity of service and invalidity pensions, as amended by Decree No. 86/262 of 26 March 1986;
- Decree No. 71/DF of 29 June 1971 fixing the rates and lists of securities, certificates or patents entitled to the technical allowance established by Decree No. 68/DF/270 of 15 July 1968 on the general regulations on remuneration schemes applicable to military personnel of the Armed Forces.
- Decree No. 80/257 of 15 July 1980 to lay down general rules and regulations governing the remuneration schemes applicable to military personnel of the Armed Forces, as amended by Decree No. 84/926 of 30 July 1984;
- Decree No. 2001/178 of 25 July 2001 on the general organisation of Defence and Central Staff;
- Decree No. 2001/219 of 06 August 2001 to lay down special rules and regulations governing non-commissioned officers of the Defence Forces;
- Decree No. 2018/190 of 02 March 2018 amending and supplementing certain provisions of Decree No. 2011/408 of 09 December 2011 to organise the Government.

REQUIREMENTS:

- be a non-commissioned service member with a technical allowance qualification/certificate;
- have an authorisation for training issued by the Minister of Defence, for military personnel in active service.

CONSTITUTION OF FILE:

- **Required documents:**
 - stamped application on *papier ministre* (ledger square paper) addressed to the Minister;
 - certified copy of certificate;
 - copy of authorisation instrument issued by the Minister of Defence, where applicable.
- **Reference document:** Staff file









DEADLINE: Sixty (60) days

SIGNATORY OF THE INSTRUMENT: the Minister

DELIVERY METHOD: Collection

QUALITY SUPERVISOR: the Director of Administrative and Regulatory Affairs

PROCESSING

DEPARTMENT OF ADMINISTRATIVE AND REGULATORY AFFAIRS	PROCEDURE No. 03/DAAR/PNO/MINDEF <u>GRANTING TECHNICAL ALLOWANCE</u>	Procedure start date: 2023	
		Procedure version:	
		Deadline	Page
<i>Intervening parties</i>	<i>Stages</i>		<i>Handling rules</i>
 Applicant  Base unit  DAAR  CSER  CBLR  CSER  DAAR	<p style="text-align: center;">Beginning</p> <ul style="list-style-type: none"> - Submits the file <p style="text-align: center;">↓</p> <ul style="list-style-type: none"> - Receives the file - Registers the file - Forwards the file to the Department of Administrative and Regulatory Affairs <p style="text-align: center;">↓</p> <ul style="list-style-type: none"> - Receives the file - Assigns the file to the CSER <p style="text-align: center;">↓</p> <ul style="list-style-type: none"> - Receives the file - Reviews - Assigns the file to the Bureau Head of Pensions Service <p style="text-align: center;">↓</p> <ul style="list-style-type: none"> - Receives the file - Initiates the draft instrument - Forwards the file to the CSER <p style="text-align: center;">↓</p> <ul style="list-style-type: none"> - Receives the file - Initials the slip and the draft instrument - Initiates the forwarding slip to the CFI - Forwards the file to the Department of Administrative and Regulatory Affairs <p style="text-align: center;">↓</p> <ul style="list-style-type: none"> - Receives the file - Signs the forwarding slip to the CF - Forwards the file to the CF 		<p>R1: Check file's compliance</p> <p>R2: Check the authenticity of information provided</p> <p>R3: Ensure that the applicant is eligible</p> <p>R4: Ensure procedure consistency</p>
FINANCIAL CONTROLLER			
	<ul style="list-style-type: none"> - Receives the file - Reviews - Initials - Forwards the file to the 		
MINDEF			

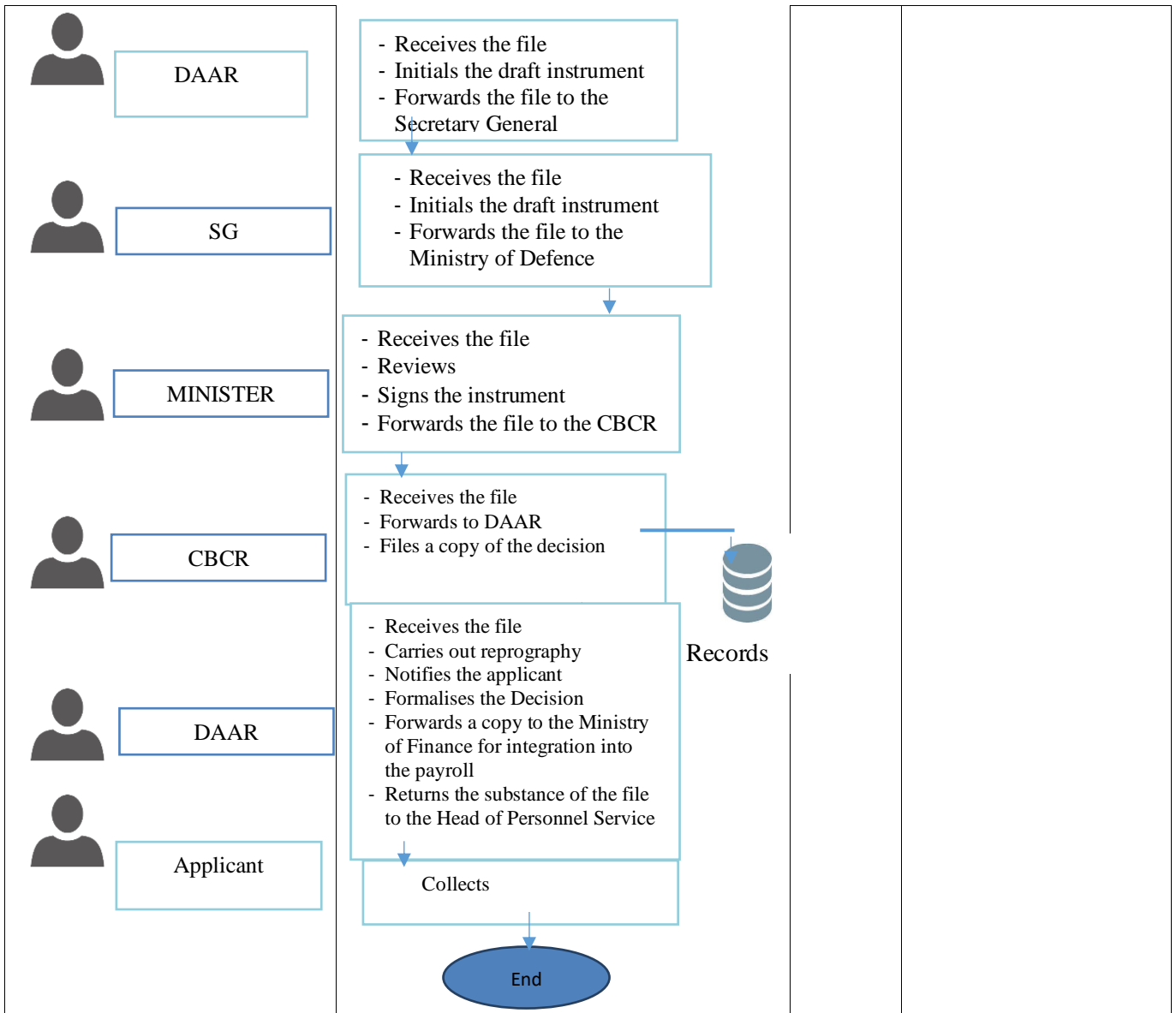

PROCEDURE No. 04/MINDEF/DAAR/PNO/I
GRANTING VEHICLE MAINTENANCE ALLOWANCE

TITLE OF THE INSTRUMENT: Decision granting vehicle maintenance allowance

INITIATOR OF THE PROCEDURE: Applicant

INITIATING ENTITY: Studies and Regulatory Service

PLACE OF SUBMISSION OF FILE: Base unit

REFERENCE INSTRUMENTS:

- Law No. 67/LF/9 of 12 June 1967 on the general organisation of Defence;
- Law No. 80/12 of 14 July 1980 on general rules and regulations governing servicemen, together with all the amendments thereto;
- Decree No. 76/460 of 12 October 1976 to organise military pension schemes based on longevity of service and invalidity pensions, as amended by Decree No. 86/262 of 26 March 1986;
- Decree No. 80/257 of 15 July 1980 to lay down general rules and regulations governing the remuneration schemes applicable to military personnel of the Armed Forces, as amended by Decree No. 84/926 of 30 July 1984;
- Decree No. 87/1142 of 20 August 1987 regulating the use of military vehicles of the commercial range, the granting of advance to military personnel and agents of the Ministry of Defence for the acquisition of personal vehicles, and the conditions for participation of the State in the expenses of maintenance of the vehicles of some service personnel;
- Decree No. 2001/219 of 06 August 2001 to lay down special rules and regulations governing non-commissioned officers of the Defence Forces;
- Decree No. 2018/190 of 02 March 2018 amending and supplementing certain provisions of Decree No. 2011/408 of 09 December 2011 to organise the Government.

REQUIREMENT: Be a service member using his/her personal vehicle for service purposes.

CONSTITUTION OF FILE:

- **Required documents:**
 - stamped handwritten application addressed to the Minister of Defence;
 - copy of vehicle registration document;
 - payslip;
 - confirmatory note from the chief of staff attesting that the owner of the vehicle is using it for service purposes.
- **Reference document:** Staff file

DEADLINE: Sixty (60) days

SIGNATORY OF THE INSTRUMENT: the Minister

DELIVERY METHOD: Collection

QUALITY SUPERVISOR: the Director of Administrative and Regulatory Affairs

PROCESSING: cf. processing chain: **PROCEDURE No. 03/DAAR/PNO/MINDEF**
GRANTING TECHNICAL ALLOWANCE

**PROCEDURE No. 05/MINDEF/DAAR/PNO/I
PAYMENT OF NON-ACCOMMODATION ALLOWANCE**

TITLE OF THE INSTRUMENT: Payslip with non-accommodation allowance

INITIATOR OF THE PROCEDURE: Applicant

INITIATING ENTITY: Combined Military Supplies Department

PLACE OF SUBMISSION OF FILE: DIRCIA

REFERENCE INSTRUMENTS:

- Law No. 67/LF/9 of 12 June 1967 on the general organisation of Defence;
- Law No. 80/12 of 14 July 1980 on general rules and regulations governing servicemen, together with all the amendments thereto;
- Decree No. 76/460 of 12 October 1976 to organise military pension schemes based on longevity of service and invalidity pensions, as amended by Decree No. 86/262 of 26 March 1986;
- Decree No. 80/257 of 15 July 1980 to lay down general rules and regulations governing the remuneration schemes applicable to military personnel of the Armed Forces, as amended by Decree No. 84/926 of 30 July 1984;
- Decree No. 87/1142 of 20 August 1987 regulating the use of military vehicles of the commercial range, the granting of advance to military personnel and agents of the Ministry of Defence for the acquisition of personal vehicles, and the conditions for participation of the State in the expenses of maintenance of the vehicles of some service personnel;
- Decree No. 2001/219 of 06 August 2001 to lay down special rules and regulations governing non-commissioned officers of the Defence Forces;
- Decree No. 2014/253 of 07 July 2014 to revalorise the basic monthly salaries of civilian and military personnel;
- Decree No. 2018/190 of 02 March 2018 amending and supplementing certain provisions of Decree No. 2011/408 of 09 December 2011 to organise the Government.

REQUIREMENT: Be an unhoused service member.

CONSTITUTION OF FILE:

• **Required documents:**

- stamped application on *papier ministre* (ledger square paper) addressed to the Minister;
- attestation of non-accommodation issued by the Department of Military Property and Infrastructure (DDMI);
- three (03) individual transfer notices signed by COMPANY commanders;
- attestation of effective presence signed by the superior;
- recent payslip.

• **Reference documents:**

- history of military earnings;
- payslip.









DEADLINE: Sixty (60) days

SIGNATORY OF THE INSTRUMENT: the Combined Military Supplies Department

DELIVERY METHOD: Collection

QUALITY SUPERVISOR: the Director of Administrative and Regulatory Affairs



PROCESSING

DEPARTMENT OF ADMINISTRATIVE AND REGULATORY AFFAIRS	PROCEDURE No. 5/DAAR/PNO/MINDEF PAYMENT OF NON-ACCOMMODATION ALLOWANCE	Procedure start date: 2023	
		Procedure version:	
		Deadline	Page
<i>Intervening parties</i>	<i>Stages</i>		<i>Handling rules</i>
			R1: Check file's compliance
 Applicant	<div style="border: 1px solid black; padding: 5px; width: fit-content; margin: 5px auto;">Submits the file</div>		R2: Check the authenticity of information provided
 Secretariat	<div style="border: 1px solid black; padding: 5px; width: fit-content; margin: 5px auto;"> <ul style="list-style-type: none"> - Receives the file - Registers the file - Forwards the file au DRCIA </div>		R3: Ensure that the applicant is eligible R4: Ensure procedure consistency
 Director of the Combined Military Supplies Department	<div style="border: 1px solid black; padding: 5px; width: fit-content; margin: 5px auto;"> <ul style="list-style-type: none"> - Receives the file - Assigns the file au CSES </div>		
 Staffing and Payroll Service	<div style="border: 1px solid black; padding: 5px; width: fit-content; margin: 5px auto;"> <ul style="list-style-type: none"> - Receives the file - Reviews - Assigns au CBS </div>		
 Head of Pay Office	<div style="border: 1px solid black; padding: 5px; width: fit-content; margin: 5px auto;"> <ul style="list-style-type: none"> - Receives the file - Carries out ANTILOPE balance entry - Forwards the file </div>		
 Head of Staffing and Payroll Service	<div style="border: 1px solid black; padding: 5px; width: fit-content; margin: 5px auto;"> <ul style="list-style-type: none"> - Receives the file - Forwards the file </div>		
 Director of the Combined Military Supplies Department	<div style="border: 1px solid black; padding: 5px; width: fit-content; margin: 5px auto;"> <ul style="list-style-type: none"> - Receives the file - Approves balance </div>		
 Applicant	<div style="border: 1px solid black; padding: 5px; width: fit-content; margin: 5px auto;">Collects</div>		

PART TWO
STANDARD OPERATIONS IN THE
PROCESSING CHAIN AND THE STAFFS

I. PROCESSING OF FILE AT THE MAIL BUREAU LEVEL

a. At the beginning of the process

<i>Intervening parties</i>	<i>Stages</i>	<i>Handling rules</i>
 Applicant  Head of Incoming Mail Bureau	<p style="text-align: center;">Beginning</p> <p style="text-align: center;">↓</p> <div style="border: 1px solid black; padding: 5px; margin: 5px 0;">Submits the file</div> <p style="text-align: center;">↓</p> <div style="border: 1px solid black; padding: 5px; margin: 5px 0;"> <ul style="list-style-type: none"> - Receives the physical file - Reviews the physical file - Registers the physical file, which automatically generates a mail number - Writes the generated number on the physical file - Issues an acknowledgement receipt to the applicant - Prints the forwarding slip - Forwards the electronic data to the Head of the General Affairs Division - Forwards the physical file to the Head of the General Affairs Division - Forwards the physical file to the Secretary of the Sub-director of Reception, Mail and Liaison </div> <p style="text-align: center;">↓</p> <p style="text-align: center;">End</p>	<p>R1: Check file's compliance</p> <p>R2: Ensure file's consistency</p>

b. When forwarding a file to another structure

<i>Intervening parties</i>	<i>Stages</i>	<i>Handling rules</i>
 Head of the Mail Bureau	<p style="text-align: center;">Beginning</p> <p style="text-align: center;">↓</p> <div style="border: 1px solid black; padding: 5px; margin: 5px 0;"> <ul style="list-style-type: none"> - Receives the physical file, the forwarding slip meant for the service concerned and the forwarding slip against receipt - Checks the conformity of physical file data with electronic data - Receives the electronic data and prints the acknowledgement receipt - Formalises the signed slip - Registers exit of the physical file - Forwards the electronic data to the services of another structure - Prints the forwarding slip - Takes the physical file under docket to the Services of the structure concerned </div> <p style="text-align: center;">↓</p> <p style="text-align: center;">End</p>	<p>R1: Ensure conformity of physical data with electronic data</p> <p>R2: Ensure that the addressee has not been mistaken</p> <p>R3: Ensure that the addressee's name is correct</p>

c. At the end of the process

<i>Intervening parties</i>	<i>Stages</i>	<i>Handling rules</i>
 <div style="border: 1px solid black; padding: 5px; display: inline-block;"> Head of the Outgoing Mail Bureau </div>	<div style="text-align: center; border: 1px solid black; border-radius: 50%; width: 100px; margin: 0 auto; padding: 5px;">Beginning</div> <div style="border: 1px solid black; padding: 10px; margin: 10px auto; width: 80%;"> <ul style="list-style-type: none"> - Receives the physical file and the decision - Initials the forwarding slip - Registers the document - Carries out reprography of the document - Formalises the document and photocopies - Registers and codifies the document - Registers exit of the file - Files a copy of the document - Returns the substance of the file and a copy of the document to the concerned - Forwards the original document to the applicant </div> <div style="text-align: center; border: 1px solid black; border-radius: 50%; width: 100px; margin: 0 auto; padding: 5px;">End</div>	<p>R1: Ensure that page numbering is respected</p> <p>R2: Ensure that confidentiality is respected</p>

II. PROCESSING AT THE SECRETARIAT LEVEL

a) RECEPTION OF FILE

<i>Intervening parties</i>	<i>Stages</i>	<i>Handling rules</i>
 <div style="border: 1px solid black; padding: 5px; display: inline-block;"> Secretary </div>	<div style="text-align: center; border: 1px solid black; border-radius: 50%; width: 100px; margin: 0 auto; padding: 5px;">Beginning</div> <div style="border: 1px solid black; padding: 10px; margin: 10px auto; width: 80%;"> <ul style="list-style-type: none"> - Receives the physical file and electronic data - Checks the conformity of physical file data with electronic data - Registers entry of the physical file - Initials the forwarding slip - Prints the acknowledgement receipt - Submits physical file to hierarchy </div> <div style="text-align: center; margin: 10px auto;">↓</div> <div style="text-align: center; border: 1px solid black; border-radius: 50%; width: 100px; margin: 0 auto; padding: 5px;">End</div>	<p>R1: Ensure conformity of physical data with electronic data</p> <p>R2: Ensure that confidentiality is respected</p> <p>R3:.....</p>

b) EXIT OF FILE

<i>Intervening parties</i>	<i>Stages</i>	<i>Handling rules</i>
 Secretary	<p style="text-align: center;">Beginning</p> <div style="border: 1px solid black; padding: 10px; margin: 10px auto; width: 80%;"> <ul style="list-style-type: none"> - Receives the physical file - Registers exit of the physical file - Prints the forwarding slip - Forwards electronic data - Returns the physical file to the dispatch runner </div> <p style="text-align: center;">End</p>	<p>R1: Ensure conformity of physical data with electronic data</p> <p>R2: Ensure that the addressee has not been mistaken</p> <p>R3: Ensure that the addressee's name is correct</p>

c) AFTER SIGNING THE INSTRUMENT

<i>Intervening parties</i>	<i>Stages</i>	<i>Handling rules</i>
 Secretary	<p style="text-align: center;">Beginnin</p> <div style="border: 1px solid black; padding: 10px; margin: 10px auto; width: 80%;"> <ul style="list-style-type: none"> - Receives the physical file and the signed decision - Forwards the decision to the Head of the Reprography Bureau - Prints the forwarding slip - Signs the decision electronically - Registers exit of the file - Submits the signed document to the dispatch runner for forwarding to the Head of the Reprography Bureau </div> <p style="text-align: center;">End</p>	<p>R1: Ensure conformity of physical data with electronic data</p> <p>R2: Ensure that the addressee has not been mistaken</p> <p>R3: Ensure that the addressee's name is correct</p>

III. PROCESSING AT THE LEVEL OF A CLERK/DISPATCH RUNNER/LIAISON AGENT

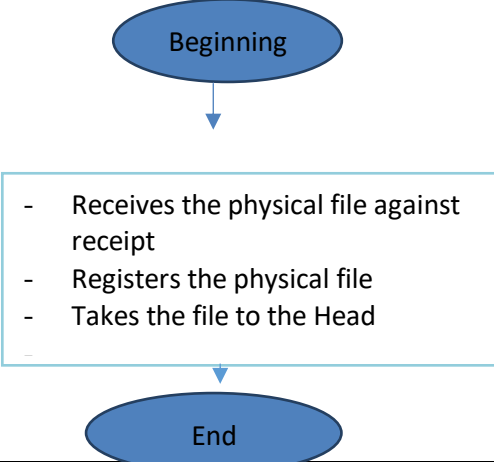
<i>Intervening parties</i>	<i>Stages</i>	<i>Handling rules</i>
 <div data-bbox="260 685 488 775" style="border: 1px solid black; padding: 2px; display: inline-block;">Secretary</div>	<div style="text-align: center;">  <pre> graph TD A([Beginning]) --> B[- Receives the physical file against receipt - Registers the physical file - Takes the file to the Head] B --> C([End]) </pre> </div>	<p>R1: Ensure conformity of physical data with electronic data</p> <p>R2: Ensure that the addressee has not been mistaken</p> <p>R3: Ensure that the addressee's name is correct</p>

IV. PROCESSING AT TECHNICAL STRUCTURE LEVEL

a) Entry of file

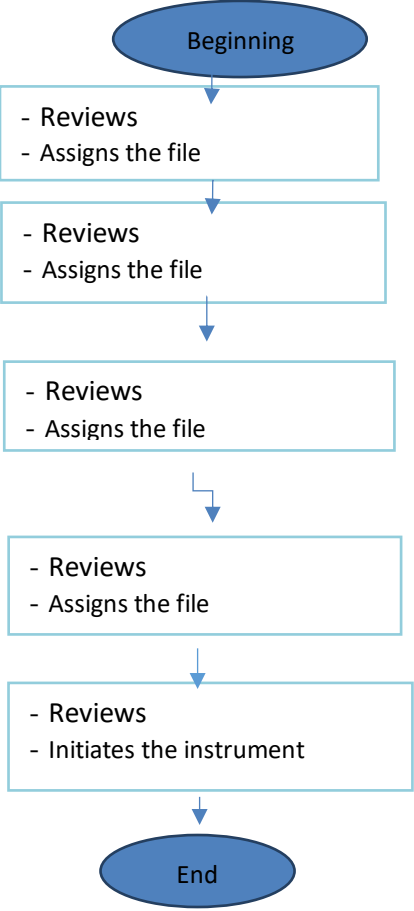
<i>Intervening parties</i>	<i>Stages</i>	<i>Handling rules</i>
 <ul style="list-style-type: none"> <li data-bbox="263 421 518 560">Director and persons ranking as such <li data-bbox="263 593 518 732">Sub-director and persons ranking as such <li data-bbox="263 766 518 904">Service Head and persons ranking as such <li data-bbox="263 938 518 1077">Deputy Service Head and persons ranking as such <li data-bbox="263 1111 518 1205">Bureau Head 	 <pre> graph TD Start([Beginning]) --> S1[- Reviews
- Assigns the file] S1 --> S2[- Reviews
- Assigns the file] S2 --> S3[- Reviews
- Assigns the file] S3 --> S4[- Reviews
- Assigns the file] S4 --> S5[- Reviews
- Initiates the instrument] S5 --> End([End]) </pre>	<p>R1: Ensure conformity of physical data with electronic data</p>

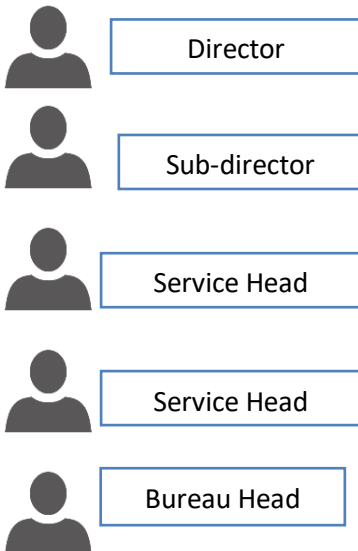
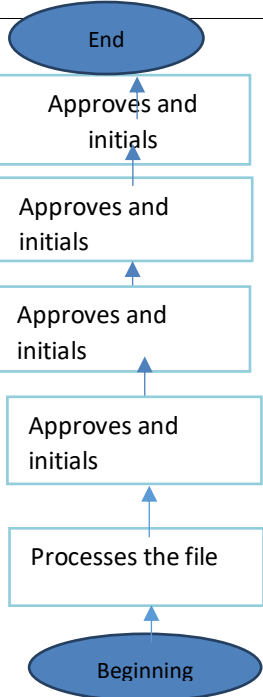

b) Exit of file











<i>Intervening parties</i>	<i>Stages</i>	<i>Handling rules</i>
 <p>Director</p> <p>Sub-director</p> <p>Service Head</p> <p>Service Head</p> <p>Bureau Head</p>	 <p>End</p> <p>Approves and initials</p> <p>Approves and initials</p> <p>Approves and initials</p> <p>Approves and initials</p> <p>Processes the file</p> <p>Beginning</p>	<p>R1: Ensure conformity of physical data with electronic data</p> <p>R2: Ensure compliance with requirements for the requested service</p> <p>R3: Ensure compliance with the chain of command</p>

V. PROCESSING AT STAFF LEVEL

A. EMAT

ARMY STAFF	Procedure No. 01/MINDEF/EMAT/I Marriage authorisation	Procedure start date: 2023
		DEADLINE
		Page :
Intervening parties	Stages	Handling rules
<p>Applicant</p> <p>Base unit</p> <p>Mail Bureau</p> <p>Chief of Staff</p> <p>Deputy Chief of</p> <p>Sub-director of Human Resource</p> <p>Director of Human Resource</p> <p>Sub-director of Training</p> <p>Deputy Chief of</p>	<p>Beginning</p> <p>Submits the file</p> <p>- Receives the file - C - Forwards the file and the investigation report to the</p> <p>- Receives the file - Checks file's compliance - Registers the file</p> <p>- Receives the file - Reviews - Assigns to the Deputy Chief of</p> <p>- Receives the file - Reviews - Assigns to the Sub-director of Human Resource</p> <p>- Receives the file - Reviews - Assigns to the Director of Human Resource</p> <p>- Receives the file - Reviews - Initiates the preliminary draft instrument and forwarding slip to DAAR - Initials the draft to the Sub-director of Training</p> <p>- Receives - Initials the slip</p> <p>- Receives - Initials the slip</p> <p>- Receives - Signs the slip - Returns the file to the Head of Administrative Services</p>	<p>R1: Check file's compliance</p> <p>R2: Check applicant's status</p> <p>R3: Check the administrative status of the spouses</p> <p>R4: Check the morality of the future spouse and the eligibility of the applicant</p>

 <p>Chief of Staff</p>  <p>Head of Administrative Services</p>	<p style="text-align: center;">↓</p> <div style="border: 1px solid black; padding: 5px;"><ul style="list-style-type: none">- Receives the card- Formalises the slip- Forwards the file to DAAR- Files a copy of the slip</div>		
---	---	--	--

AIR FORCE STAFF		Procedure start date: 2023	
		DEADLINE	Procedure version: 1.0
			Page
<i>Intervening parties</i>	<i>Stages</i>		<i>Handling rules</i>
 Applicant  Base Unit Commander/ Chief of Service  COCOM/SERVICE HEAD  COM GPMT/ COM BAFUSAIR  SERCOM HEAD  COMBA  Mail Bureau  Head of Administrative Services  MAGE  Sub-director of Human Resource  Director of Human Resource	<p style="text-align: center;">Beginning</p> <p style="text-align: center;">Submits the file ↓</p> <p style="text-align: center;">↓</p> <div style="border: 1px solid black; padding: 5px; margin-bottom: 5px;"> - Receives the physical file - Checks file conformity - Forwards the file to COCOM </div> <p style="text-align: center;">↓</p> <div style="border: 1px solid black; padding: 5px; margin-bottom: 5px;"> - Receives the physical file - Forwards to COM GPMT or COMBAFUSAIR </div> <p style="text-align: center;">↓</p> <div style="border: 1px solid black; padding: 5px; margin-bottom: 5px;"> - Receives the physical file - Forwards to the Secretary of the SERCOM Head </div> <p style="text-align: center;">↓</p> <div style="border: 1px solid black; padding: 5px; margin-bottom: 5px;"> - Receives the file - Forwards the file to COMBA </div> <p style="text-align: center;">↓</p> <div style="border: 1px solid black; padding: 5px; margin-bottom: 5px;"> - Receives the physical file - Forwards the file to CEMAA </div> <p style="text-align: center;">↓</p> <div style="border: 1px solid black; padding: 5px; margin-bottom: 5px;"> - Receives the physical file - Forwards the file to CSA </div> <p style="text-align: center;">↓</p> <div style="border: 1px solid black; padding: 5px; margin-bottom: 5px;"> - Receives the physical file - Forwards the file to MAGE </div> <p style="text-align: center;">↓</p> <div style="border: 1px solid black; padding: 5px; margin-bottom: 5px;"> - Receives the physical file - Assigns the file to SCRH </div> <p style="text-align: center;">↓</p> <div style="border: 1px solid black; padding: 5px; margin-bottom: 5px;"> - Receives the physical file - Assigns to CBR </div> <p style="text-align: center;">↓</p> <div style="border: 1px solid black; padding: 5px; margin-bottom: 5px;"> - Receives the file - Initiates the preliminary draft instrument and the forwarding slip to DAAR </div> <p style="text-align: center;">↓</p>		<p>R1: Ensure that the file is compliant and complete</p> <p>R2: Check applicant's status and eligibility</p> <p>R3: Check the authenticity of personal information provided and ensure procedure consistency</p>

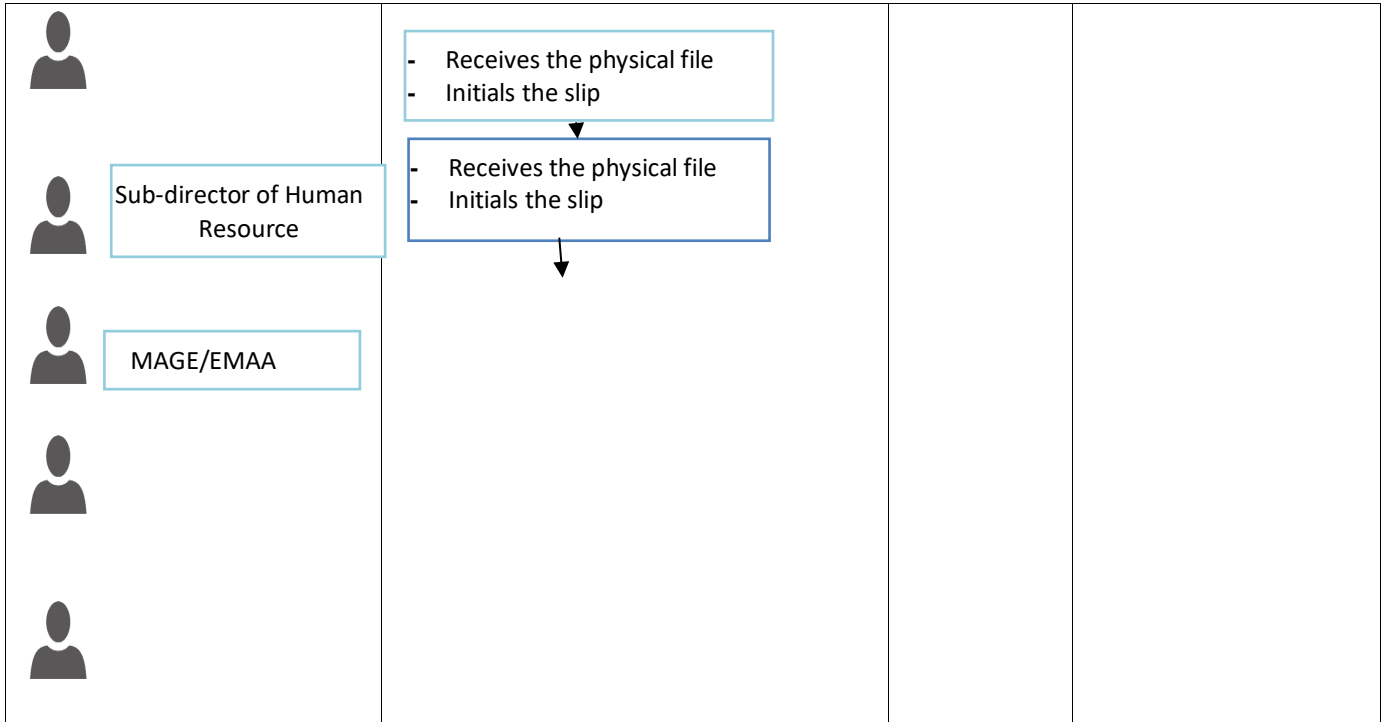

B. EMAA

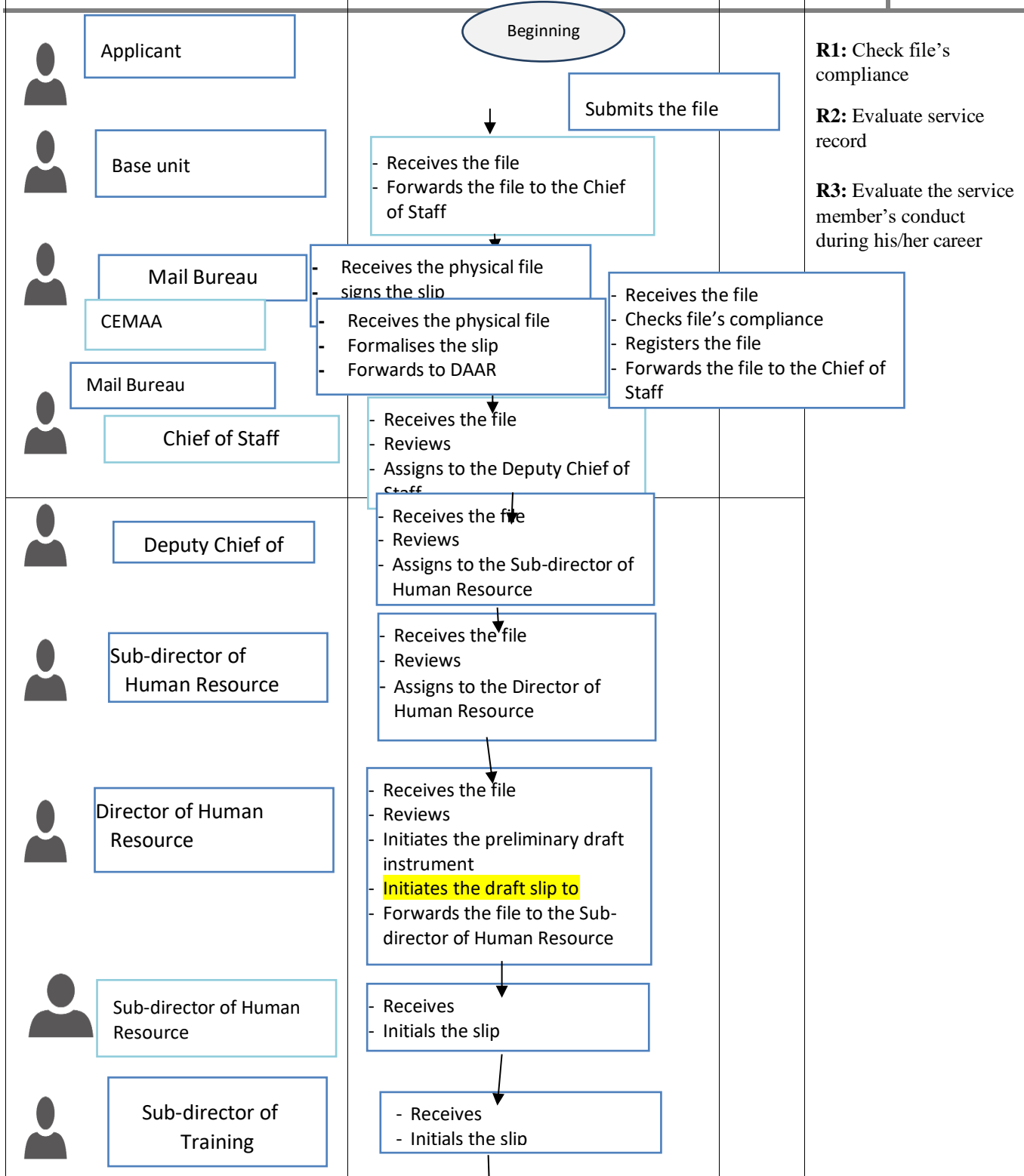

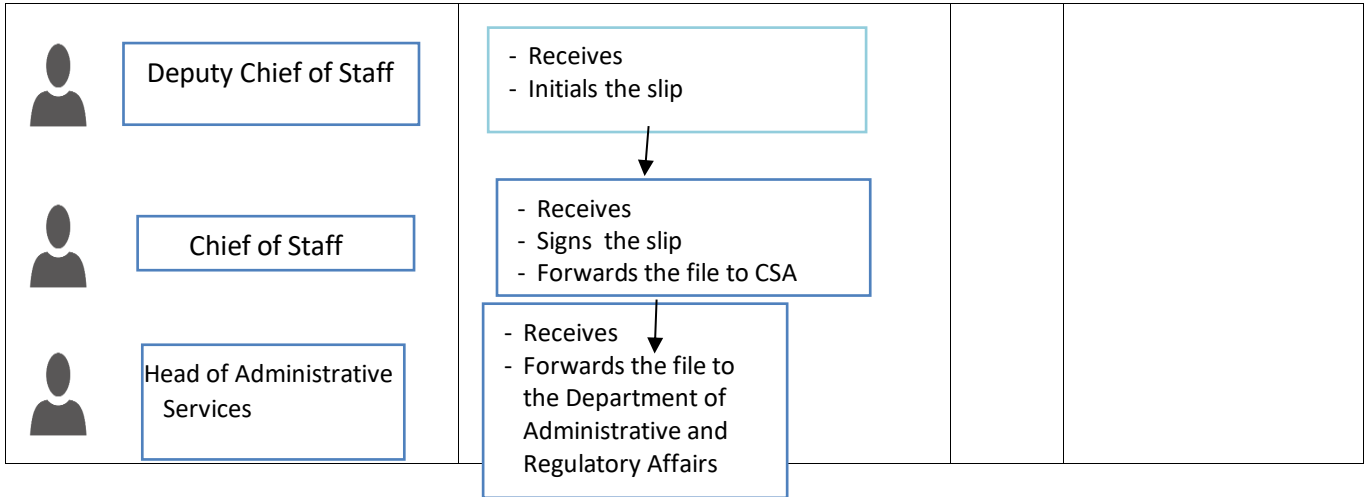

C. EMM

D. NATIONAL GENDARMERIE

NATIONAL GENDARMERIE	Procedure start date:		
	Procedure version:		
	Page		
Intervening parties	Stages	Deadline: Six (06) months	Handling rules
<p>Beginning</p>	<p>Applicant</p> <p>Base Unit Head</p> <p>Mail, Documentation and Records Service</p> <p>The Secretary of State to the Minister of Defence in charge of the National Gendarmerie</p> <p>Head of Mail, Documentation and Records Service, DCC</p> <p>Central Coordination Director</p> <p>Director of Personnel</p> <p>Head of Chancellery Service</p> <p>Head of Civilian Personnel and Reserve Bureau</p> <p>Head of Chancellery Service</p> <p>Director of Personnel</p>		<p>R1: Check file consistency and compliance</p> <p>R2: Ensure the eligibility of the applicant and the spouse</p> <p>R3: Conduct a background check of the future spouse</p> <p>R4: Check the authenticity of documents</p>

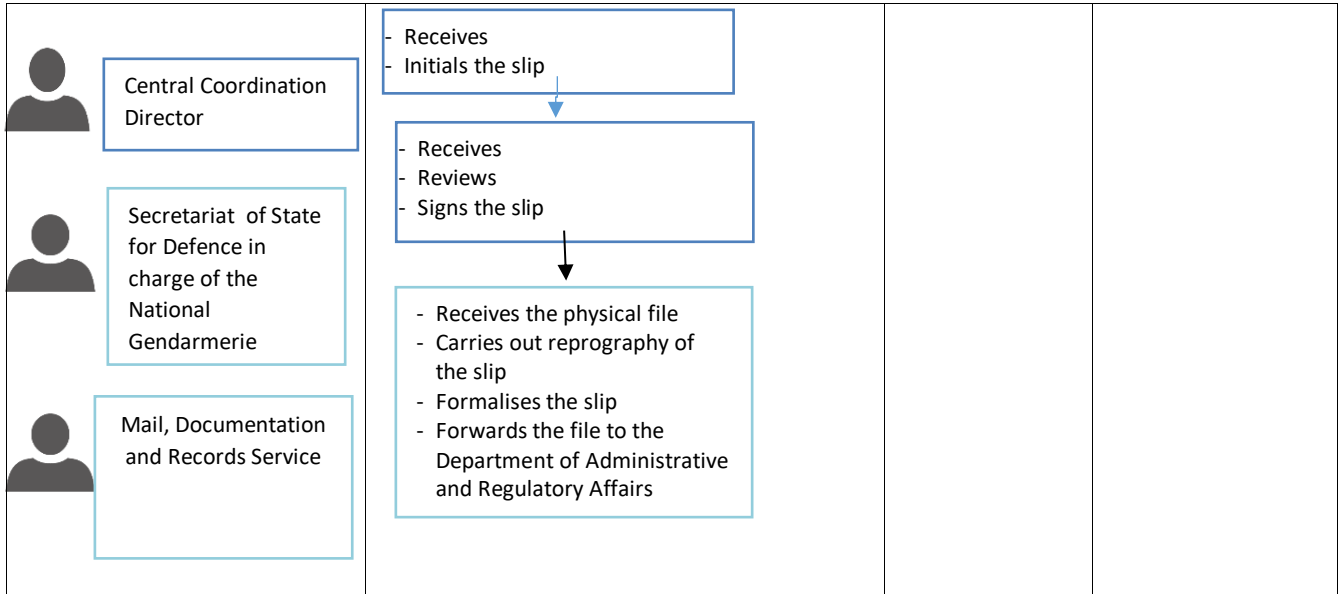

PRODUCTION TEAM

❖ **Supervision:**

- Mr SAID KAMSSOULOU, Secretary General/MINDEF;
- Mr TCHAGADICK NJILLA Yves Alain, Permanent Secretary for Administrative Reform/ MINFOPRA.

❖ **Administrative Coordination:** Colonel SONE AJANG Joseph SONE, DAAR/MINDEF.

❖ **Technical Coordination:** Mr TSIMI Serge, DAS/MINFOPRA.

❖ **MINDEF Point focal:** Cdt ABANDA MINKANDA Jean J., Head of Organisation and Methods Unit/MINDEF.

❖ **Team Leader:** Mrs AFFANA Nicole, Assistant Administrative Organisation Adviser/MINFOPRA.

❖ **Rapporteur:** Mr BEKONO Bernard Armand, COA/SPRA/MINFOPRA.

❖ **Members:**

a) OPERATIONAL TEAM

- Mr EVOLA née NGAH Justine, COA/SPRA/MINFOPRA;
- Mr EKOTTI Silas PALE, COA/SPRA/ MINFOPRA;
- Mr BEA Marc Claude, Cadre/SPRA/MINFOPRA;
- Mrs EPASSI née AYOUNG Solange Rachel, SEC/SPRA/MINFOPRA.

b) REPRESENTATIVES OF MINDEF STRUCTURES

- CO DZOZONG ALIENOU, GN/MINDEF;
- C/E DJOUNANG KAMDOUM, GN/MINDEF;
- CE NGAME NSILE HANS, GN/MINDEF;
- LT EBOGO ONDOUA, GB/MINDEF;
- Cdt MATAM Pie Claude, DAAR/MINDEF;
- Cdt FOGUE Tala Alain, DRH/MINDEF;
- CV ATANGANA, DIRCIA/MINDEF;
- M. NKOUNDE Jean Paul, CF/MINFI ;
- LCL NANGA Myriam, DRH/MINDEF;
- SLT EVINA JEANINE, DRH/MINDEF;
- CE MESSOUGLA José S., DAAR/MINDEF;
- Cne NVONDO Eric, DAAR/MINDEF;
- LV DAIPA YANDA M, DIRCIA/MINDEF;
- AT TINGUIRA GERVAIS, GN/MINDEF;
- LT ESSIANE ESSIANE Cyrille, EMP/MINDEF;
- CBA LEP Thomas, EMAT/MINDEF;
- SLY ABESOLO Julie, DRH/MINDEF;
- LT LIPOT Adrienne, DRH/MINDEF;
- M. EBEDE Ignace, DRH/MINDEF;
- LCL ZO'O NNA Guy , EMAA/MINDEF;
- Cne TCHISSA TCHEKAM, EMAA/MINDEF;
- LT Ange EVAN Evariste OWONA, SG/MINDEF;
- CB ATANGANA Roger, GN/MINDEF.